

C4 and C4C KAYE CORNER CHAIRS

(effective 2/26/03)

These are the user instructions for the C4 and C4C Kaye Corner Chairs. All persons who set-up or adjust the unit should first read these entire instructions. Please store these instructions for future reference.

USE

The Kaye Corner Chairs are designed for children who need support of the head, trunk, and pelvis in order to develop an upright sitting posture and to align the head and trunk.

SIZES AND MODELS

The corner chairs come in two sizes: the smaller C4 and larger C5.

Optional casters can be added to both the C4 and C5. With casters, the C4 becomes a C4C, and the C5 becomes a C5C.

CORNER CHAIR IDENTIFICATION, AND SIZE AND WEIGHT LIMITS

The model number is located on the warning label.

The C4 or C4C is appropriate for users from 8 months to 4 years old, up to 39 inches or 99 centimeters tall, or who weigh up to 40 pounds or 18 kilograms.

BOX CONTENTS

The following should be included in the shipping box:

- 1 ea. Chair Assembly;
- 2 ea. Head Cushions; and
- 1 ea. Tray Assembly.

If you ordered the chair with optional casters, the following should be included in the inner box:

- 4 ea. Casters;
- 16 ea. Bolts; and
- 16 ea. Lock Washers.

CASTER ATTACHMENT AND USE

Attach, lock, and unlock the optional casters as follows:

1. Place a lock washer on each of the 16 bolts.
2. Turn the corner chair on its side so that you have access to the underside of the base.
3. Align the holes in each caster plate with the holes in each corner of the base.
4. Secure each caster in place with four of the bolts and washers, and securely tighten the bolts.
5. To lock the casters so that they will not roll, step on the metal brake that protrudes from each caster. Once this brake is rotated fully downward, it will prevent the wheel from rolling.
6. To unlock the casters, rotate the brakes upward.
7. The casters should be locked whenever the chair is not being intentionally moved.

HEAD CUSHION ATTACHMENT AND ADJUSTMENT

Position the head cushions to help keep the user's head aligned.

On the back of each chair side, there are two black knobs near the top edge. Use these knobs to secure the head cushions in place as follows:

1. Remove the knobs and washers to expose the protruding bolts.
2. Install each head cushion assembly so that the two bolts protrude through the slot in that assembly. As you install the assembly, orient the cushion towards the chair seat.
3. Reinstall a washer and black knob onto each bolt.
4. Tighten the knobs.
5. To adjust the height of the head cushion, loosen the knobs, reposition the cushion, and re-tighten the knobs.

TRAY INSTALLATION

Install the tray assembly as follows:

1. On the outside of each tray side is a block with a barrel bolt. To install the tray, rotate the barrel bolt latches upward and then outward so that the barrel bolts point towards the outside of the tray.
2. On the inside of the tray sides there are a few small, wooden blocks. Position the tray assembly on the front of the chair so that a set of these blocks

rests on top of the rails that protrude from the outside corners of the seat.

3. Position the tray as far back as it will go, and then rotate each of the barrel bolt latches inward so that the barrel bolts lock behind the edge of the tray sides.
4. Rotate each of the barrel bolt latches downward to lock the barrel bolts in place.

TRAY HEIGHT ADJUSTMENT

Adjust the tray height to comfortably support the user's arms and thereby assist with upper body positioning.

Adjust the tray height as follows:

1. Slide the barrel bolt latches upward and outward to remove the tray assembly.
2. Reposition the tray by resting a different set of the small, wooden blocks on the seat rails.
3. Reinstall the tray.

TRAY DEPTH ADJUSTMENT

Adjust the distance between the tray and the back cushion as follows:

1. Loosen but do not remove the two black knobs on the outside of each tray side.
2. Slide the tray in or out.
3. Re-tighten the four knobs.

SEAT HEIGHT ADJUSTMENT

Adjust the seat height to control the bend in the user's knees. To help maintain the position of the pelvis, adjust the seat so the user's knees and hips are both flexed.

Adjust the seat height as follows:

1. Remove the tray.
2. On the back of one of the chair sides there is a black knob on level with the seat. On the other side there is a thumb screw on level with the seat. Remove the knob, its washer, and the thumb screw.
3. There is a bolt protruding from where you removed the knob. Remove the seat from the side by pulling it in a direction so that the bolt pulls through the hole in the side.
4. Move the seat up or down.
5. Reinstall the seat by inserting the above mentioned bolt and the one behind it into a set of holes in the side.
6. Reinstall the washer and knob onto the bolt.

7. Align the thumb screw, at the same height as the knob, and insert it into the hole in the side and then into the hole in the side of the seat.
8. Securely tighten the thumb screw and then the knob.

ABDUCTOR DEPTH ADJUSTMENT

Adjust the abductor's position to keep the users' legs separated and to help keep the pelvis aligned.

Adjust the abductor depth as follows:

1. Remove the tray and seat.
2. Turn the seat upside down and use a Phillips screw driver to remove the two screws and washers that secure the abductor rod to the seat.
3. Reposition the abductor.
4. Reinstall and tighten the two screws and washers.
5. Reinstall the seat and tray.

BACK CUSHION REMOVAL

Use the back cushion when the child needs additional support along the spine in order to maintain a sitting posture. Remove the back cushion if this additional support is not needed.

Remove the back cushion as follows:

1. Remove the tray and seat.
2. Turn the seat upside down and use a Phillips screw driver to remove the two bolts and washers that hold the back cushion bracket in place.
3. Remove the back cushion and reinstall the seat and tray.

BELT USE

Position the belt around the hips to maintain pelvic posture or around the chest to maintain upper body posture.

Adjust the belt as follows:

1. To unfasten the buckle, simultaneously depress the tabs at the top and at the bottom edges of the buckle.
2. To fasten the buckle, insert the male end into the female end until the two tabs click into place. After fastening the buckle, always pull on the belt to ensure that it is securely fastened.
3. To tighten or loosen the buckle, lengthen or shorten the loose end of the belt by pulling the material through the male end of the buckle. Do not remove the male end from the belt.

MAINTENANCE AND CARE

Inspect the unit regularly. Tighten the hardware as necessary.

If the unit needs service or spare parts, contact Kaye Products, Inc. or the distributor from whom you purchased the unit.

If a problem is discovered that may impact the unit's function, immediately cease use and contact Kaye Products, Inc.

Do not expose the unit to rain or submerge it in water.

Use a slightly damp cloth to clean the unit, but wipe the dampness from the wood after cleaning it.

Avoid any undue stress to the unit while using, storing, or transporting it.

LIMITED WARRANTY

If an item proves defective within two years of the original purchase, we will provide replacement parts in order to correct that defect. Normal wear and tear is not covered by the warranty.

Kaye Products, Inc. makes no other warranty, expressed or implied, and does not warrant the product as being fit for a particular purpose. The purchaser, owner, and user assume all risk of personal and property injury due to the use of the equipment.

CAUTIONS

1. Do not adjust the chair while it is in use.
2. Before use, ensure that all hardware is securely tightened.
3. Do not use the unit if there are broken or missing parts.
4. Do not exceed the size or weight limits.
5. Do not alter the unit or use it in any way other than described herein.
6. Do not leave the user unattended.
7. Use qualified supervision.
8. Do not stand on the unit.
9. Keep the casters locked unless you are intentionally moving the unit.
10. Always use the seat belt.

Left Side

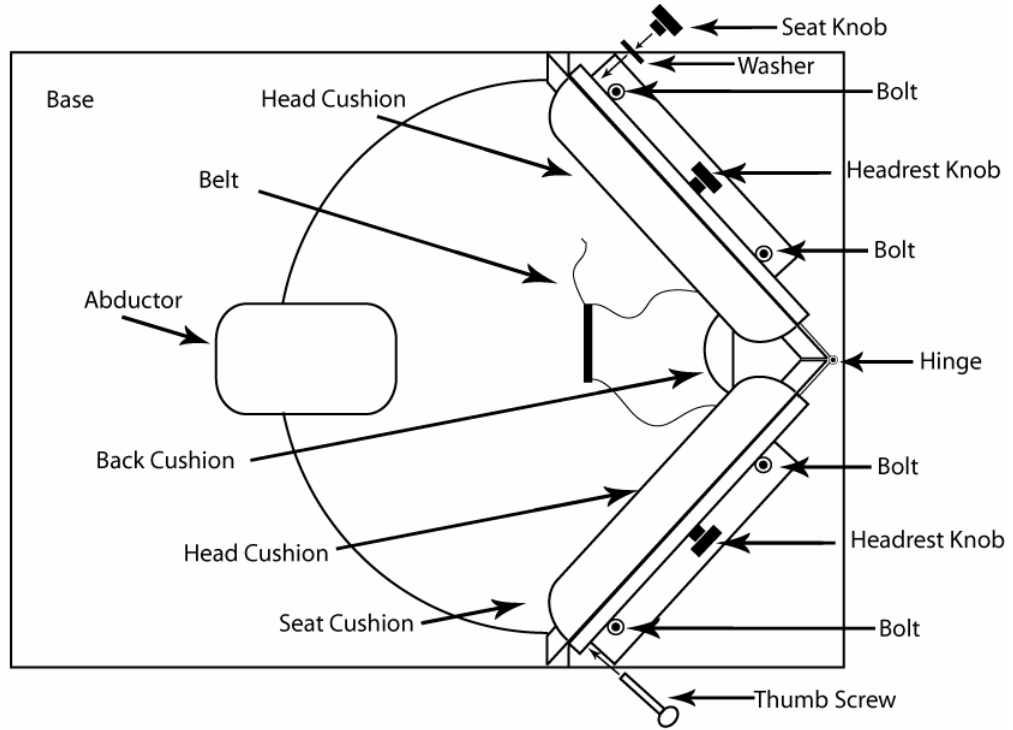

Right Side

