



## Breezy<sup>®</sup> 600

**Supplier:** This manual must be given to the user of this wheelchair.

**User:** Before using this wheelchair read this entire manual and save for future reference.

Owner's Manual

## Breezy<sup>®</sup> 600

**Distribuidor:** Este manual debe ser entregado al pasajero de esta silla de ruedas.

**Pasajero:** Antes de usar esta silla de ruedas, lea este manual en su totalidad y guárdelo para futura referencia.

Cada una de las sillas se envía con un manual de instrucciones en inglés. El manual en español o francés está disponible en formato PDF en nuestra página en [Ingrese a la página del producto específico para descargar el manual](#), o comuníquese con el proveedor autorizado de Sunrise Medical.

Manual de Instrucciones

## Breezy<sup>®</sup> 600

**Fournisseur :** Ce manuel doit être remis à l'utilisateur / utilisatrice de ce fauteuil roulant.

**Utilisateur / Utilisatrice :** Avant d'utiliser ce fauteuil roulant, lisez entièrement ce manuel et conservez le pour le consulter ultérieurement.

Chaque fauteuil est livré avec un manuel d'instructions en anglais. Les versions en espagnol et en français sont à votre disposition en format PDF sur le [Veillez vous rendre à la page de votre produit pour télécharger le manuel dans la langue souhaitée](#), ou contactez un fournisseur agréé Sunrise Medical.

Mode d'emploi



**SUNRISE LISTENS**

Thank you for choosing a Breezy wheelchair. We want to hear your questions or comments about this manual, the safety and reliability of your chair, and the service you receive from your Sunrise supplier.

Sunrise Medical (US) LLC

Be sure to return your warranty card, and let us know if you change your address. This will allow us to keep you up to date with information about safety, new products and options to increase your use and enjoyment of this wheelchair. If you lose your warranty card, call or write and we will gladly send you a new one.

**FOR ANSWERS TO YOUR QUESTIONS**

If you have questions regarding the safe use and/or assembly, maintenance, or specifications of your wheel chair, U.S. customers contact Customer Service  
Please have the model and serial number of the product available.

Supplier: \_\_\_\_\_

Address: \_\_\_\_\_

\_\_\_\_\_

Telephone: \_\_\_\_\_

Serial #: \_\_\_\_\_ Date/Purchased: \_\_\_\_\_

**INFORMATION YOU SHOULD KNOW**

No component of this chair was made with Natural Rubber Latex

**DISPOSAL AND RECYCLING INFORMATION**

When this product reaches the end of its life, please take it to an approved collection or recycling point designated by your local or state government. This wheelchair is manufactured using a variety of materials. Your product should not be disposed of as ordinary household waste. You should dispose of your wheelchair properly, according to local laws and regulations. Most materials that are used in the construction of this product are fully recyclable. The separate collection and recycling of your product at the time of disposal will help conserve natural resources and ensure that it is disposed in a manner that protects the environment.

Ensure you are the legal owner of the product prior to arranging for the product disposal in accordance with the above recommendations.

I. INTRODUCTION .....	2	F. Solid Tires.....	11
II. TABLE OF CONTENTS .....	3	G.Positioning Belts Option.....	11
III. YOUR CHAIR AND ITS PARTS .....	4	H Push handles Option.....	12
IV. NOTICE - READ BEFORE USE .....	5	I. Quick-Release Axles.....	12
V. GENERAL WARNINGS.....	5	J. Rear Wheels.....	12
A.Weight Limits .....	5	K.Rear Wheel Locks.....	12
B. Intended Use .....	5	L. Modified Seat Systems.....	12
C.Attendants and Caregivers .....	5	M.Seat and Back Upholstery.....	12
D.Accessories .....	5	<b>VIII. USE AND MAINTENANCE .....</b>	<b>13</b>
E. Know Your Chair .....	5	A. Introduction .....	13
F. Reduce The Risk of an Accident .....	6	B. Critical safety checks .....	13
G.Safety Checklist .....	6	C.Cleaning Tips .....	13
H.Changes & Adjustments .....	6	D.Safety Checklist .....	13
I. Environmental Conditions .....	6	E. Troubleshooting Chart.....	13
J. Terrain .....	6	F. To Mount and Remove Rear Wheels .....	14
K.Street Use .....	6	G.Wheel Locks .....	14
L. Motor Vehicle Safety .....	6	H.Anti-tips tubes.....	14
M.When You Need Help .....	6	I. Armrests.....	15
<b>VI. WARNINGS: FALLS AND TIP-OVERS .....</b>	<b>7</b>	J. Swing-in Swing-out hangers .....	15
A. Center of Balance .....	7	K.Seating and Seat Sling Upholstery .....	16
B. Dressing or Changing Clothes .....	7	L. Folding and Unfolding.....	16
C.Obstacles .....	7	M. Storage Tips.....	16
D.Front Caster Lift .....	7	N.Check-Out .....	16
E. Reaching or Leaning .....	8	<b>IX. DEALER SERVICE AND ADJUSTMENT .....</b>	<b>18</b>
F. Moving Backward .....	8	A.Dealer Service Introduction.....	18
G.Escalators .....	8	B. Critical Maintenance Tips.....	18
H.Ramps, Slopes & Sidehills .....	8	C.Cleaning.....	18
I. Transfers .....	9	D.Standard and low front seat heights .....	18
J. Curbs & Single Steps.....	9	E. Rear Wheel Axle Nut Adjustment .....	19
K. Climbing a Curb or Single step .....	10	F. Wheel Lock Adjustment.....	19
L. Descending a Curb or Single step .....	10	G.Caster Forks .....	19
M.Stairs .....	10	H.Casters .....	20
N.Climbing Stairs .....	10	I. Footrest height adjustment.....	20
O.Descending Stairs .....	10	J. Seat sling replacement.....	21
<b>VII. WARNINGS: COMPONENTS AND OPTIONS.....</b>	<b>11</b>	K.Backrest upholstery replacement.....	21
A. Anti-tip Tubes .....	11	L. Backrest .....	21
B. Armrests.....	11	<b>X. SUNRISE LIMITED WARRANTY.....</b>	<b>23</b>
C. Cushions and Seat Slings .....	11		
D.Fasteners.....	11		
E. Footrests.....	11		

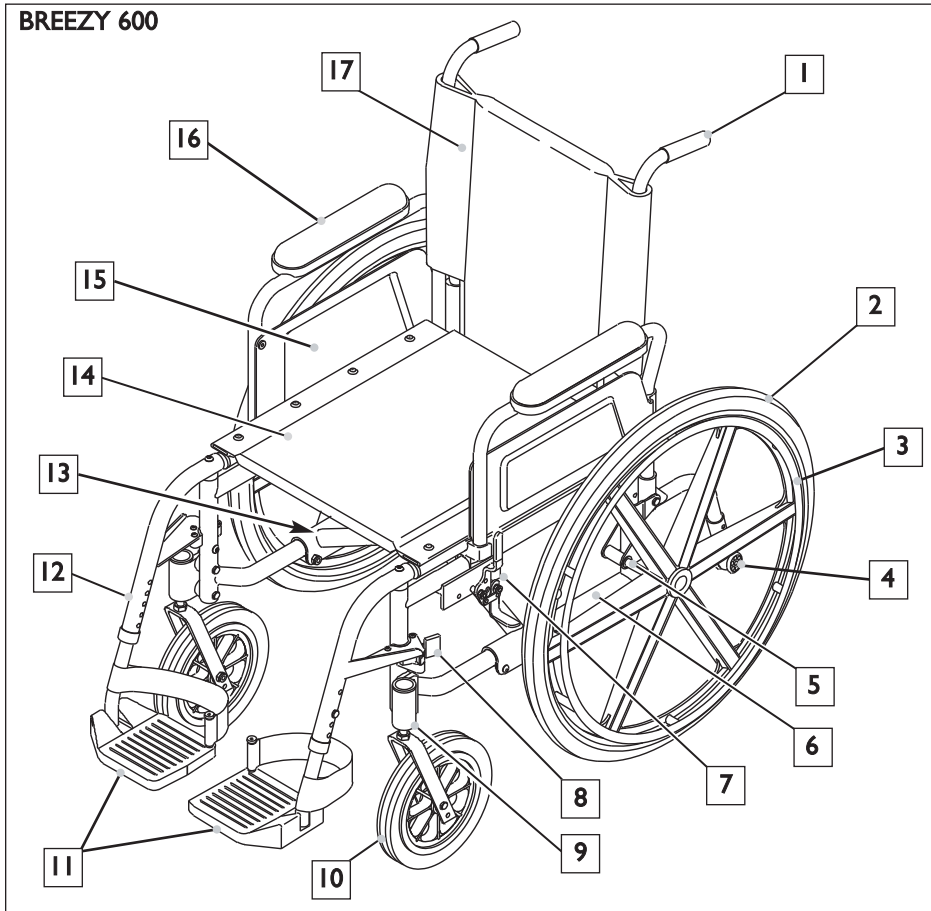

1. Push handle and adjustable back tube
2. Rear wheel
3. Handrim
4. Anti-tip
5. Axle
6. Sideframe
7. Wheel lock
8. Hanger latch release
9. Caster housing
10. Caster wheel
11. Footplate
12. Swing-away Footrest
13. Crossbrace
14. Padded seat sling
15. Side Guard
16. Armrest
17. Backrest

All features may not be available with some chair setups or in conjunction with another chair feature. Please consult your authorized supplier for more information.

## BREEZY 600

### Weight (basic configuration)

28 lbs. (12.7 kg)

### Adjustments

1" (25 mm) Vertical Axle- Adjustment, 2-Hole Fork Footrest Extension Adjustment, Adjustable Caster Housing, Backrest Adjustment

### Colors

Blue, Silver Texture, Forest Green, Black

### Frame Dimensions

Seat Width - 14", 16", 18", 20"  
(356 mm, 406 mm, 457 mm, 508 mm)

Seat Depth  
16", 18"  
(406 mm, 457 mm)

### Backrest

16" - 19" (406 mm - 483 mm)

### Armrests

Fixed height Desk, Fixed height (Full)  
Flip-back height-adjustable (Desk)  
Flip-back height-adjustable (Full)

### Hangers

60°, 70°  
ELR, ALR

### Footplates

Std - Composite with heel loop  
Opt - Aluminum  
Ext. tubes - short, med., long

### Axles / Axle plate

Std - Offset Fixed axle plate  
Threaded axle  
Opt - Quick-Release  
One-arm drive

### Anti-Tip Tubes

Opt - Rear Anti-Tip Tubes

### Casters

5", 8" (127 mm, 203 mm)  
Polyurethane & pneumatic  
1 1/2"(38 mm)  
caster fork stem

### Wheel Locks

Std - High push-to-lock, High pull to-lock,  
Opt - 6" (152 mm) extension  
handles, grade aids

### Rear Wheels

Type: Std -mag,  
Sizes: Std - 24", 22", Opt - 20"  
Tires: Std - low profile polyurethane  
Opt - pneumatic, full-profile polyurethane,  
airless inserts

### Handrims

Std - composite, aluminum  
Opt - plastic-coated

### Projections Handrims

Opt - 8 oblique

**A. CHOOSE THE RIGHT CHAIR & SAFETY OPTIONS**

Sunrise provides a choice of many wheelchair styles to meet your needs. This product is intended for single person use only. Final selection of the type of wheelchair, options and adjustments rests solely with you and your health care professional. Choosing the best chair for your unique mobility needs, will depend on such things as:

1. Your disability, strength, balance and coordination.
2. The types of hazards you must overcome in daily use (where you live and work, and other places you are likely to use your chair).
3. The need for options that will improve your positioning, safety and comfort (such as anti-tip tubes, positioning belts, or special seating systems).

**B. REVIEW THIS MANUAL OFTEN**

Before using this chair you, and each person who may assist you, should read this entire manual and make sure to follow all instructions. Review the warnings often, until they are second nature to you.

**C. WARNINGS** 

The word "WARNING" refers to a hazard or unsafe practice that may cause severe injury or death to you or to other persons. The "Warnings" are in three main sections, as follows:

**I. V — GENERAL WARNINGS**

Here you will find a safety checklist and a summary of risks you need to be aware of before you ride this chair.

**2. VI— SAFETY WARNINGS: FALLS & TIP-OVERS**

Here you will learn about practices for the safe use of your chair, and how to avoid a fall or tip-over while you perform daily activities in your chair.

**3. VII — WARNINGS — COMPONENTS & OPTIONS**

Here you will learn about the components of your chair and options you can select for safety. Consult your authorized supplier and your health care advisor to help you choose the best set-up and options for safe use.

**NOTE—** Where they apply, you will also find "Warnings" in other sections of this manual. Heed all warnings in these sections. If you fail to do so a fall, tip-over or loss of control may occur and cause severe injury to the rider or others.

## V. GENERAL WARNINGS

**A. WEIGHT LIMITS** **WARNING**

NEVER exceed the weight limit specified by Sunrise Medical. The weight capacity provided by your manufacturer is for the combined weight of a rider and items carried using on-board storage. If you do exceed the weight limit, damage to your chair, a fall, tip-over or loss of control may occur and cause severe injury to the rider or others.

**Weight Capacity**

**Breezy 600** - 250lbs/(113kg).

**B.—INTENDED USE**

The Breezy 600 wheelchair's intended use is to provide mobility to persons limited to a sitting position.

 **WARNING**

DO NOT use this device for purposes other than what is intended by the manufacturer

1. The wheelchair is not designed for weight training and is unsafe for use as a seat while weight training. Weight training from the wheelchair substantially changes the stability of the chair and may cause tipping.
2. DO NOT stand on the frame of the wheelchair.
3. NEVER allow someone to stand on your chair or use it as a step ladder.
4. This chair is designed for a single rider only.
5. Unauthorized modifications and use of parts or accessories not supplied or approved by Sunrise Medical may change the chair structure. This will void the warranty and may cause a safety hazard. If the warning is ignored, damage to your chair, and a potential of severe injury to the person using the chair can occur.

**C. ATTENDANTS AND CAREGIVERS** **WARNING**

Before you assist a rider, be sure to read all warnings contained in this manual, and follow all instructions that apply. Be aware that after consulting a healthcare advisor, you will need to learn safe and proven body mechanics to use and create assistive methods best suited to your abilities.

**D. ACCESSORIES** **WARNING**

Unauthorized modifications or use of parts, or accessories not supplied or approved by Sunrise Medical may change the chair structure. This will void the warranty and may cause a safety hazard.

Some problems that may occur, but are not limited to:

1. Incorrect Wheels and/or tires that put the rider at risk of a fall or tip-over.
2. Adding a component to the frame, including any type of power assist, changing the structural integrity of the chair.
3. Any modification or disassembly that can potentially create an unsafe situation where rider and/or attendant are put at risk.

**E. KNOW YOUR CHAIR** **WARNING**

Every wheelchair is different. Take the time to learn the feel of this chair before you begin riding. Start slowly, with easy, smooth strokes. If you are used to a different chair, you may use too much force and tip over. If you use too much force, damage to your chair, a fall, tip-over or loss of control may occur and cause severe injury to the rider or others.

**F. REDUCE THE RISK OF AN ACCIDENT****⚠ WARNING**

1. BEFORE you begin riding, you should be trained in the safe use of this chair by your health care advisor.
2. Practice bending, reaching and transfers until you know the limit of your ability. Have someone help you until you know what can cause a fall or tip-over and how to avoid doing so.
3. Be aware that you must develop your own methods for safe use best suited to your level of function and ability.
4. NEVER try a new maneuver on your own. Ask the advice of your health care provider to lower the risk of a fall or tip over.
5. Get to know the areas where you plan to use your chair. Look for hazards and learn how to avoid them.

**G. SAFETY CHECKLIST****⚠ WARNING**

Before Each Use Of Your Chair:

1. Make sure the chair rolls easily and that all parts work smoothly. Check for noise, vibration, or a change in ease of use. (This may indicate low tire pressure, loose fasteners, or damage to your chair).
2. Inspect any problem. Your authorized dealer can help you find and correct the problem
3. Check to see that both quick-release rear axles are locked. When locked, the axle button will “pop out” fully. If not locked, the wheel may come off and cause you to fall.
4. If your chair has anti-tip tubes, lock them in place.

**H. CHANGES & ADJUSTMENTS****⚠ WARNING**

1. See your healthcare advisor and have them adjust seating components any time a change or adjustment needs to be made.
2. Unauthorized modifications or use of parts not supplied or approved by Sunrise may change the chair structure. This will void the warranty and may cause a safety hazard.

If you fail to heed these warnings damage to your chair, a fall, tip-over or loss of control may occur and cause severe injury to the rider or others.

**I. ENVIRONMENTAL CONDITIONS****⚠ WARNING**

1. Use extra care if you must ride your chair on a wet or slick surface. If you are in doubt, ask for help.
2. Contact with water or excess moisture may cause your chair to rust or corrode. Avoid all extreme weather situations if possible.
  - a. Do not use your chair in a shower, pool or other body of water. The chair tubing and parts are not water-tight and may rust or corrode from the inside.
  - b. Avoid excess moisture (for example, do not leave your chair in a damp bathroom while taking a shower).
  - c. Dry your chair as soon as you can if it gets wet, or if you use water to clean it.

If you fail to heed these warnings damage to your chair, a fall, tip-over or loss of control may occur and cause severe injury to the rider or others.

**J. TERRAIN****⚠ WARNING**

1. Based on ANSI/RESNA testing, Sunrise Medical recommends the use of a caster wheel with a minimum diameter of 5", if the wheel-chair will be overcoming obstacles up to 1/2" on a regular basis.
2. Your chair is designed for use on firm, even surfaces such as concrete, asphalt, indoor flooring, and carpets.
3. Do not operate your chair in sand, loose soil, or over rocky terrain.
4. If you use your chair on terrain that is rougher than described above there is a danger that screws and bolts will loosen prematurely, and that damage to wheels or axles could put the rider at risk of a fall, tip-over, or loss of control.

If you fail to heed these warnings damage to your chair, a fall, tip-over or loss of control may occur and cause severe injury to the rider or others.

**K. STREET USE****⚠ WARNING**

1. This product is not intended for street use.
2. Avoid streets whenever possible.
3. Obey and follow all legal pedestrian pathways, and laws that apply to pedestrians.
4. Be alert to the danger of motor vehicles in parking lots, or if you must cross a road.

If you fail to heed this warning, damage to your chair, and a possible collision may occur and cause severe injury to the rider or others.

**L. MOTOR VEHICLE SAFETY** 1 2

If possible and feasible, the rider should transfer to the Original Equipment Manufacturer vehicle seat and use the OEM vehicle restraint.

**⚠ WARNING**

This chair is **NOT** equipped with a Transit Option:

1. NEVER let anyone sit in this chair while in a moving vehicle.
  - a. ALWAYS move the rider to an approved vehicle seat.
  - b. ALWAYS secure the rider with proper motor vehicle restraints.
2. In an accident or sudden stop the rider may be thrown from the chair. Wheelchair seat belts will not prevent this, and further injury may result from the belts or straps.
3. NEVER transport this chair in the front seat of a vehicle. It may shift and interfere with the driver.
4. ALWAYS secure this chair so that it cannot roll or shift.
5. Do not use any chair that has been involved in a motor vehicle accident. The frame and/or components may have been changed due to the accident. Such items could be, but are not limited to: bent, loosened, and/or broken components that were subjected to an impact.

Failure to heed these warnings puts you and others that may assist you at a high risk of injury.

**M. WHEN YOU NEED HELP****⚠ WARNING**

**For The Rider:** Make sure that each person who helps you reads and follows all warnings and instructions that apply.

**For Attendants:**

1. Work with the rider's doctor, nurse or therapist to learn safe methods best suited to your abilities and those of the rider.
2. Tell the rider what you plan to do, and explain what you expect the rider to do. This will put the rider at ease and reduce the risk of an accident.

3. Make sure the chair has push handles. They provide secure points for you to hold the rear of the chair to prevent a fall or tip-over. Check to make sure push handle grips will not rotate or slip off.
4. To prevent injury to your back, use good posture and proper body mechanics. When you lift or support the rider or tilt the chair, bend your knees slightly and keep your back as upright and straight as you can.
5. Remind the rider to lean back when you tilt the chair backward.
6. When you descend a curb or single step, slowly lower the chair in one easy movement. Do not let the chair drop the last few inches to the ground. This may damage the chair or injure the rider.

7. To avoid tripping, unlock and rotate anti-tip tubes up, out of the way.
8. Whenever you aren't attending the wheelchair, ALWAYS use the wheel-lock to secure the rear wheels, and lock the anti-tip tubes in place.

If you fail to ask for help when in doubt, you run a high risk of a fall, tip-over or loss of control that may occur and cause severe injury to the rider or others.

## VI. WARNINGS: FALLS AND TIP-OVERS

### A. CENTER OF BALANCE

#### WARNING

The point where this chair will tip forward, back or to the side depends on its center of balance and stability. How your chair is set up, the options you select and the changes you make may affect the risk of a fall or tip-over.

1. The Most Important Adjustment Is:  
The position of the rear wheels. The more you move the rear wheels forward, the more likely your chair will tip over backward.
2. The Center Of Balance Is Also Affected By:
  - a. A change in the set-up of your chair, including:
    - The distance between the rear wheels.
    - The amount of rear wheel camber.
    - The seat height and seat angle.
    - Backrest angle.
  - b. A change in your body position, posture or weight distribution.
  - c. Riding your chair on a ramp or slope.
  - d. A back pack or other options and the amount of added weight.
3. To Reduce The Risk Of An Accident:
  - a. Consult your doctor, nurse or therapist to find out what axle and caster position is best for you.
  - b. Consult your authorized supplier BEFORE you modify or adjust this chair. Be aware that you may need to make other changes to correct the center of balance.
  - c. Have someone help you until you know the balance points of your chair and how to avoid a tip-over.
  - d. Use anti-tip tubes.

If you fail to heed these warnings, you are at a high risk of a fall, tip-over or loss of control that could cause severe injury to the rider or others.

### B. DRESSING OR CHANGING CLOTHES

#### WARNING

Your weight may shift if you dress or change clothes while seated in this chair.

- To reduce the risk of a fall or tip-over:
1. Rotate the front casters until they are as far forward as possible. This makes the chair more stable.
  2. Lock anti-tip tubes in place. If your chair does not have anti-tip tubes, back it up against a wall.
  3. Lock both rear wheels.

If you fail to heed this warning, damage to your chair, a fall, tip-over or loss of control may occur and cause severe injury to the rider or others.

### C. OBSTACLES

#### WARNING

Riding over curbs or obstacles can cause tipping and serious bodily harm. If you have any doubt that you can safely cross any curb or obstacle, ALWAYS ASK FOR HELP. Be aware of your riding skills and personal limitations. Develop new skills only with the help of a companion.

To avoid the risk of traversing obstacles:

1. Keep a lookout for danger – scan the area well ahead of your chair as you ride.
2. Make sure the floor areas where you live and work are level and free of obstructions.
3. Remove or cover threshold strips between rooms.
4. Install a ramp at entry or exit doors. Make sure there is not a drop off at the bottom of the ramp.
5. To Help Correct Your Center Of Balance:
  - a. Lean your upper body FORWARD slightly as you go UP over an obstacle.
  - b. Press your upper body BACKWARD as you go DOWN from a higher to a lower level.
6. If your chair has anti-tip tubes, do not go over an obstacle without help.
7. Keep both of your hands on the handrims as you go over an obstacle.
8. Never push or pull on an object (such as furniture or a doorjamb) to propel your chair.

If you fail to heed these warnings damage to your chair, a fall, tip-over or loss of control may occur and cause severe injury to the rider or others.

### D. FRONT CASTER LIFT

#### WARNING

Front caster lift can occur when the front wheels, ordinarily in contact with the ground, are either intentionally, or unintentionally caused to lift from the ground while the rear wheels remain in contact. Pitch control (partial or full) should NEVER be attempted without consulting your healthcare advisor and making sure that anti-tips are installed.

If you fail to heed this warning, you are at a high risk of damage to your chair, a fall, tip-over or loss of control that may occur and cause severe injury to the rider or others.

## E. REACHING OR LEANING

### ⚠ WARNING

If you reach or lean it will affect the center of balance of your chair. This may cause you to fall or tip over. When in doubt, ask for help or use a device to extend your reach.

1. NEVER reach or lean if you must shift your weight sideways or rise up off the seat.
2. NEVER reach or lean if you must move forward in your seat to do so. Always keep your buttocks in contact with the backrest.
3. NEVER reach with both hands (you may not be able to catch yourself to prevent a fall if the chair tips).
4. NEVER reach or lean to the rear unless your chair has anti-tip tubes locked in place.
5. DO NOT reach or lean over the top of the seat back. This may damage one or both backrest tubes and cause you to fall.
6. If You Must Reach Or Lean:
  - a. Do not lock the rear wheels. This creates a tip point and makes a fall or tip-over more likely.
  - b. Do not put pressure on the footrests.
  - c. Move your chair as close as you can to the object you wish to reach.
  - d. Do not try to pick up an object from the floor by reaching down between your knees. You are less likely to tip if you reach to the side of your chair.
  - e. Rotate the front casters until they are as far forward as possible. This makes the chair more stable.
  - f. Firmly grasp a rear wheel or an armrest with one hand. This will help to prevent a fall if the chair tips.

If you fail to heed these warnings damage to your chair, a fall, tip-over or loss of control may occur and cause severe injury to the rider or others.

## F. MOVING BACKWARD

### ⚠ WARNING

Use extra care when you move your chair backward. Your chair is most stable when you propel yourself forward. You may lose control or tip over if one of the rear wheels hits an object and stops rolling.

1. Propel your chair slowly and smoothly.
2. If your chair has anti-tip tubes, make sure to lock them in place.
3. Stop often and check to be sure your path is clear.

If you fail to heed this warning, you are at a high risk of damage to your chair, a fall, tip-over or loss of control that may occur and cause severe injury to the rider or others.

## G. ESCALATORS

### ⚠ WARNING

NEVER use this chair on an escalator, even with an attendant. If you do, a fall or tip-over is likely.

## H. RAMPS, SLOPES & SIDEHILLS

### ⚠ WARNING

Whenever possible, avoid riding on a slope, which includes a ramp or side-hill. This will change the center of balance of your chair. Your chair is less stable and more difficult to maneuver when it is at an angle. When moving up a hill, anti-tip tubes may not prevent a fall or tip-over.

1. **DO NOT** use your chair on a slope steeper than 4.8%. (A 4.8% slope means: one foot in elevation for every 13 feet of slope length.)
2. **ALWAYS** go as straight up and as straight down as you can. (Do not "cut the corner" on a slope or ramp.)
3. **DO NOT** turn or change direction on a slope.

4. When you have to use a ramp, always stay in the CENTER of the ramp. Make sure ramp is wide enough that you have no risk of going off the edge.
5. **DO NOT** stop on a steep slope. If you stop, you may lose control of your chair.
6. **NEVER** use rear wheel locks to try to slow or stop your chair. This is likely to cause your chair to veer out of control.
7. **ALWAYS** be aware of:
  - a. Wet or slippery surfaces.
  - b. A change in grade on a slope (or a lip, bump or depression). These may cause a fall or tip-over.
  - c. A drop-off at the bottom of a slope or ramp. A drop-off as small as 3/4 inch can stop a front caster and cause the chair to tip forward.
8. To Reduce The Risk Of A Fall Or Tip-Over:
  - a. Lean or press your body UPHILL. This will help adjust for the change in the center of balance caused by the slope or sidehill.
  - b. Keep pressure on the handrims to control your speed on a down slope. If you go too fast you may lose control.
  - c. **ASK FOR HELP** any time you are in doubt.
9. Ramps At Home & Work– For your safety, ramps at home and work must meet all legal requirements for your area:
  - a. **AVOID A DROP-OFF**  
Make sure there is a section at the top or bottom to smooth out the transition.
  - b. **ALWAYS** stay in the center of the ramp and control your speed.

If you fail to heed these warnings damage to your chair, a fall, tip-over or loss of control may occur and can possibly cause severe injury to the rider or others.

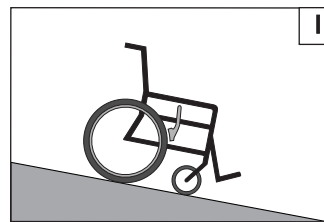

- IF** you need to go down a hill:
- a. The Downslope should be less than 4.8°.
  - b. **GO SLOW** Control your speed.
  - c. **ALWAYS** Go Straight down.
  - d. Never turn on a hill.
  - e. **ALWAYS** lean backward.

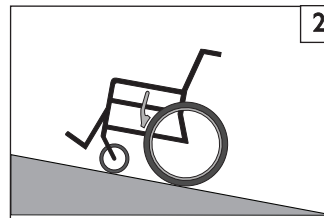

- IF** you need to go up a hill:
- a. The Upslope should be less than 4.8°.
  - b. **ALWAYS** Go Straight up.
  - c. **DON'T STOP**.
  - d. **NEVER** turn on a hill.
  - e. **ALWAYS** lean forward.

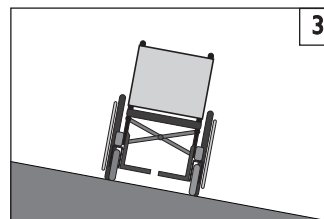

- IF** you need to traverse a Sidehill:
- a. The sidehill must be Less than 4.8° or you are at risk of a tip over.
  - b. **DON'T STOP**.
  - c. **NEVER** turn on a hill.

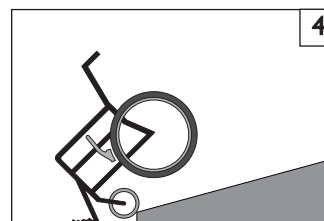

- IF** you need to traverse a Ramp:
- a. Go Slowly.
  - b. **Watch out for Drop-offs**.
  - c. **ALWAYS** go straight up or straight down.
  - d. Stay centered on the Ramp.



I. TRANSFERS 5 6**⚠ WARNING**

It is dangerous to transfer on your own. It requires good balance and agility. Be aware that there is a point during every transfer when the wheelchair seat is not below you. To avoid a fall:

1. Work with your health care advisor to learn safe methods for transfers.
  - a. Learn how to position your body and how to support yourself during a transfer.
  - b. Have someone help you until you learn safe transfer methods.
2. Lock the rear wheels before you transfer.
3. Be aware that the chair can still slide and/or tip. The wheel lock keeps the rear wheels from rolling while you are performing the transfer.
4. Make sure that the pneumatic tires are properly inflated. Low tire pressure may allow the rear wheel locks to slip. (see table in Section G "Pneumatic Tires")
5. Move your chair as close as you can to the seat you are transferring to. If possible, use a transfer board.
6. Rotate the front casters until they are as far forward as possible.
7. If you can, remove the footrests, or swing them out of the way.
  - a. Make sure your feet do not catch in the space between the footrests.
  - b. Avoid putting weight on the footrests as this may cause the chair to tip.
8. Make sure armrests are removed, or out of the way and do not interfere with the transfer.
9. Transfer as far back onto the seat surface as you can. This will reduce the risk that the chair will tip or move away from you.

Optimum Transfer position



Before transferring:

1. Flip-back or remove the armrests.
2. Swing-away, or remove the footrests.
3. Make sure the wheel lock is set.

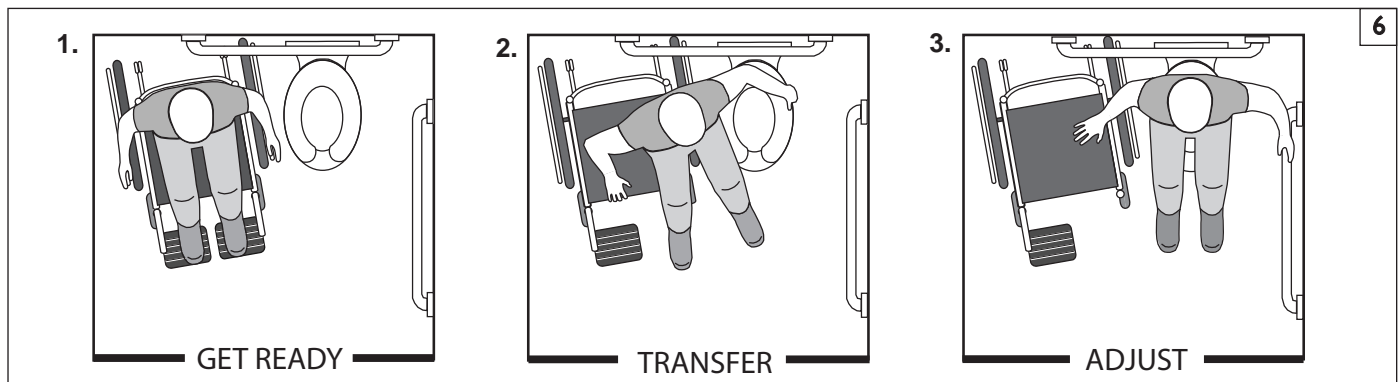
J. CURBS & SINGLE STEPS 7**⚠ WARNING**

Before riding over curbs, and negotiating even a single step, ALWAYS ask for assistance first. Curbs and steps can cause tipping and serious bodily harm. When in doubt as to your ability to avoid, or traverse any obstacle, always ask for help. Be aware of your riding skills and personal limitations. Develop new skills only with the help of a companion.

**For Attendant:** Each person who assists the rider with curbs and steps should read and follow all instructions and warnings pertaining to attendants, and caregivers.

1. Do not try to climb a high curb or step (more than 4 inches high) UNLESS you have help. Doing so may cause your chair to exceed its balance point and tip over.
2. Go straight up and straight down a curb or step. If you climb or descend at an angle, a fall or tip-over is likely.
3. Be aware that the impact of dropping down from a curb or step can damage your chair or loosen fasteners.

If you fail to heed these warnings damage to your chair, a fall, tip-over or loss of control may occur and can possibly cause severe injury to the rider or others.

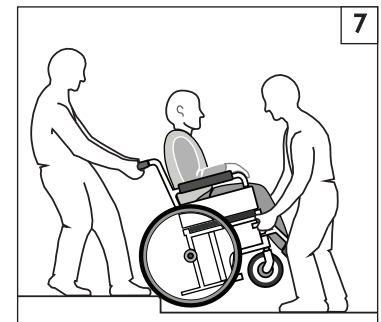

**K. CLIMBING A CURB OR SINGLE STEP** 7**⚠ WARNING**

**For Attendant:** follow these steps to help the rider climb a curb or single step going **BACKWARD**:

1. Stay behind the chair.
2. Continue backward until the rear wheels contact the face of the curb or step. Lift and roll the rear wheels to the top of the curb.
3. Pull the chair backwards until the caster wheels have cleared the edge of the curb and return the chair to its rolling position.

If you fail to heed these warnings damage to your chair, a fall, tip-over or loss of control may occur and cause severe injury to the rider or others.

**L. DESCENDING A CURB OR SINGLE STEP** 7**⚠ WARNING**

**For Attendant:** Follow these steps to help a rider descend a curb or single step going **FORWARD**:

1. Stay at the rear of the chair.
2. Several feet before you reach the edge of the curb or step, tip the chair slightly and pull it backward.
3. When the chair is at its balance point, carefully step forwards until the rear wheels reach the edge of the curb or step. Then allow the rear wheels to slowly roll down onto the lower level.
4. Push the chair forward until you are standing on the lower level.
5. When the rear wheels are safely on the lower level, tilt the chair back to its balance point.

If you fail to heed these warnings damage to your chair, a fall, tip-over or loss of control may occur and cause severe injury to the rider or others.

**M. STAIRS** 8**⚠ WARNING**

1. **NEVER** use this chair on stairs **UNLESS** you have someone to help you. Doing so is likely to cause a fall or tip-over.
2. Negotiating stairs with a wheelchair always requires at least 2 attendants for safety.

If you fail to heed these warnings damage to your chair, a fall, tip-over or loss of control may occur and cause severe injury to the rider or others.

**N. CLIMBING STAIRS** 8**⚠ WARNING**

1. Use at least two attendants to move a chair and rider up stairs.
2. Move the chair and rider **BACKWARD** up the stairs.
3. The person at the rear is in control. He or she tilts the chair back to its balance point.
4. A second attendant at the front firmly grasps a non-detachable part of the front frame and lifts the chair up and over one stair at a time.
5. The attendants move to the next stair up. Repeat for each stair, until you reach the landing.

If you fail to heed these warnings damage to your chair, a fall, tip-over or loss of control may occur and cause severe injury to the rider or others.

**O. DESCENDING STAIRS** 8**⚠ WARNING**

1. Use at least two attendants to move a chair and rider down stairs.
2. Move the chair and rider **FORWARD** down the stairs.
3. The person at the rear is in control. He or she tilts the chair to the balance point of the rear wheels and rolls it to the edge of the top step.
4. A second attendant stands on the third step from the top and grasps the chair frame. He or she lowers the chair one step at a time by letting the rear wheels roll over the stair edge.
5. The attendants move to the next stair down. Repeat for each stair, until you reach the landing.

If you fail to heed these warnings damage to your chair, a fall, tip-over or loss of control may occur and cause severe injury to the rider or others.

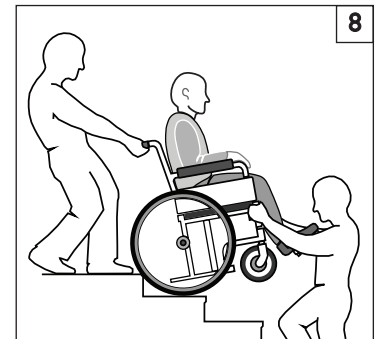

**A. ANTI-TIP TUBES****⚠ WARNING**

Anti-tip tubes can help keep your chair from tipping over backward in normal conditions.

1. Sunrise recommends the use of anti-tip tubes:
2. When locked in place (in the “down” position) anti-tip tubes should be **BETWEEN** 1 1/2 to 2 in, (3.8-5cm) off the ground.
  - a. If set **higher** than 2 in, (5cm) they may not prevent a tip-over.
  - b. If set **lower** than 2 in, (5cm) they may “hang up” on obstacles and cause a fall or tip over.
3. If you have to climb or descend a curb, or overcome an obstacle it may be necessary to have an attendant make sure the anti-tip tubes are rotated up, and out of the way, so that the chair and rider do not get stuck and/or become unstable.

If you fail to heed these warnings damage to your chair, a fall, tip-over or loss of control may occur and cause severe injury to the rider or others.

**B. ARMRESTS****⚠ WARNING**

Armrests detach and will not bear the weight of this chair.

1. **NEVER** lift this chair by its armrests. They may come loose or break.
2. Lift this chair only by non-detachable parts of the main frame.

If you fail to heed these warnings damage to your chair, a fall, tip-over or loss of control may occur and cause severe injury to the rider or others.

**C. CUSHIONS & SLING SEATS****⚠ WARNING**

1. Breezy sling seats and standard foam cushions are not designed for the relief of pressure.
2. If you suffer from pressure sores or if you are at risk that they will occur, you may need a special seat system or a device to control your posture. Consult your doctor, nurse or therapist to find out if you need such a device for your well-being.
3. Seat slings are not intended to be used as a direct seating surface. A cushion or other seating surface should be placed on the sling before use.

If you fail to heed these warnings severe injury to the rider may occur.

**D. FASTENERS****⚠ WARNING**

Many of the screws, bolts and nuts on this chair are special high-strength fasteners. Use of improper fasteners may cause your chair to fail.

1. **ONLY** use fasteners provided by an authorized supplier (or ones of the same type and strength, as indicated by the markings on the head of the bolt).
2. Over- or under-tightened fasteners may fail or cause damage to chair parts.
3. If bolts or screws become loose, tighten them as soon as you can.

If you fail to heed these warnings damage to your chair, a fall, tip-over or loss of control may occur and cause severe injury to the rider or others.

**E. FOOTRESTS****⚠ WARNING**

1. At the lowest point, footrests should be **AT LEAST** 2 in (5cm) off the ground. If set too **LOW**, they may “hang up” on obstacles you can expect to find in normal use. This may cause the chair to stop suddenly and tip forward.
2. To Avoid A Trip Or Fall When You Transfer:
  - a. Make sure your feet do not “hang up” or get caught in the space between the footrests.
  - b. Avoid putting weight on the footrests, as the chair may tip forward.
  - c. Footrests should be swung out of the way or removed whenever entering or exiting the wheelchair.
3. **NEVER** lift this chair by the footrests. Footrests detach and will not bear the weight of this chair. Lift this chair only by non-detachable parts of the main frame.
4. **NEVER** use the footrests of your chair to open doors, this may cause them to fail prematurely and create an unsafe situation.

If you fail to heed these warnings damage to your chair, a fall, tip-over or loss of control may occur and cause severe injury to the rider or others.

**F. SOLID TIRES****⚠ WARNING**

Replace your solid tires if any of the following is evident:

1. Cracked, worn, or broken tire material.
2. Flat spots on the tires that prevent smooth rolling.

If you fail to heed these warnings damage to your chair, a fall, tip-over or loss of control may occur and cause severe injury to the rider or others.

**G. POSITIONING BELTS (Optional)****⚠ WARNING**

The positioning belt is predominately used to support your posture. It can also be used to limit slipping and sliding that you might experience when the chair is in motion. The positioning belt is not a transit rated safety belt. Improper use of Positioning belts may cause severe injury or death. If you use a positioning belt, be sure to follow the recommendations below:

1. Make sure the rider does not slide down in the wheelchair seat. If this occurs, the rider may suffer chest compression or suffocate due to pressure from the belts.
2. The belts must be snug, but must not be so tight that they interfere with breathing. You should be able to slide your open hand, flat, between the belt and the rider.
3. A pelvic wedge or a similar device can help keep the rider from sliding down in the seat. Consult with the rider’s doctor, nurse or therapist to find out if the rider needs such a device.
4. Use positioning belts only with a rider who can cooperate. Make sure the rider can easily remove the belts in an emergency.
5. **NEVER** Use Positioning Belts:
  - a. As a patient restraint. A restraint requires a doctor’s order.
  - b. On a rider who is comatose or agitated.
  - c. As a motor vehicle restraint. In an accident or sudden stop the rider may be thrown from the chair. Wheelchair seat belts will not prevent this, and further injury may result from the belts or straps.

If you fail to heed these warnings damage to your chair, a fall, tip-over or loss of control may occur and cause severe injury to the rider or others.

**H. PUSH HANDLES****⚠ WARNING**

When you have an attendant, make sure that this chair has push handles.

1. Push handles provide secure points for an attendant to hold the rear of this chair, to prevent a fall or tip-over.
2. Check to make sure push handle grips will not rotate or slip off.

If you fail to heed these warnings damage to your chair, a fall, tip-over or loss of control may occur and cause severe injury to the rider or others.

**I. QUICK-RELEASE AXLES****⚠ WARNING**

1. Do not use this chair UNLESS you are sure that both quick-release rear axles are locked.
2. An axle is not locked until the quick-release button pops out fully.
3. An unlocked axle may come off during use, resulting in a fall, tip-over or loss of control and cause severe injury to the rider or others.
4. Quick-Release Axles should be periodically cleaned and inspected for function and signs of wear or bending. Replace as necessary.

If you fail to heed these warnings damage to your chair, a fall, tip-over or loss of control may occur and cause severe injury to the rider or others.

**J. REAR WHEELS****⚠ WARNING**

A change in set-up of the rear wheels will affect the center of balance of your chair.

1. The farther you move the rear axles FORWARD, the more likely it is that your chair will tip over backward.
2. Consult your healthcare advisor to find the best rear axle set-up for your chair. Do not change the set-up UNLESS you consult your healthcare advisor first.
3. Adjust the rear wheel locks after you make any change to the rear axles.
  - a. If you fail to do so, the wheel locks may not work.
  - b. Make sure lock arms embed in the tires at least 1/8 inch when locked.

If you fail to heed these warnings damage to your chair, a fall, tip-over or loss of control may occur and cause severe injury to the rider or others.

**K. REAR WHEEL LOCKS****⚠ WARNING**

Rear wheel locks are NOT designed to slow or stop a moving wheelchair. Use them only to keep the rear wheels from rolling when your chair is at a complete stop.

1. NEVER use rear wheel locks to try to slow or stop your chair when it is moving. Doing so may cause a fall or tip-over
2. To keep the rear wheels from rolling, always set both rear wheel locks when you transfer to or from your chair.
3. Low pressure in a rear tire may cause the wheel lock on that side to slip and may allow the wheel to turn when you do not expect it.
4. Make sure lock arms embed in tires at least 1/8 inch when locked. If you fail to do so, the locks may slip.

If you fail to heed these warnings damage to your chair, a fall, tip-over or loss of control may occur and cause severe injury to the rider or others.

**L. MODIFIED SEAT SYSTEMS****⚠ WARNING**

Use of a seat system not approved by Sunrise may alter the center of balance of this chair. This may cause the chair to tip over.

1. Do not change the seat system of your chair UNLESS you consult your authorized supplier first.
2. Use of a seating system not approved by Sunrise may affect the folding mechanism of this chair.

If you fail to heed these warnings damage to your chair, a fall, tip-over or loss of control may occur and cause severe injury to the rider or others.

**M. SEAT AND BACK UPHOLSTERY****⚠ WARNING**

1. Replace worn or torn fabric of seat and seat back as soon as you can. If you fail to do so, the seat or seat back may fail.
2. Sling fabric will weaken with age and use. Look for fraying, thin spots, or stretching of fabrics especially at edges and seams.
3. "Dropping down" into your chair will weaken fabric and result in the need to inspect and replace the seat more often.
4. Be aware that laundering or excess moisture may reduce the flame retardation qualities of the fabric.
5. If Tension Adjustable upholstery is present, loosen straps or remove upholstery prior to folding or unfolding the chair.

If you fail to heed these warnings damage to your chair, a fall, tip-over or loss of control may occur and cause severe injury to the rider or others.

The owner of this chair is responsible for making sure that it has been setup and adjusted by a trained service professional under the advice of a healthcare advisor. The chair may require periodic safety and function checks, or certain in-use adjustments that may be performed by the owner or caregiver. Always use parts and/or accessories that have been recommended or approved by Sunrise Medical when maintaining this chair.

**A. INTRODUCTION**

1. Proper maintenance will improve performance and extend the useful life of your chair.
2. Clean your chair regularly. This will help you find loose or worn parts and make your chair easier to use. You will need a mild detergent solution and plenty of cleaning rags.
3. If discovered, repair or replace loose, worn, bent or damaged parts **before using the chair**. ALWAYS be sure to use Parts and/or accessories that have been recommended or approved by Sunrise Medical.
4. To protect your investment, have all major maintenance and repair work done by your Authorized Dealer.
5. **Inspect and maintain this chair strictly per the maintenance chart.**
6. **If you detect a problem, make sure to order parts, or have service, and repair work done at your authorized dealer before use.**
7. **At least once per year, have a complete inspection, safety check, and service of your chair made by an Authorized Dealer.**

**B. CRITICAL SAFETY CHECKS**

1. Tire Integrity

Check solid tires at least **ONCE PER WEEK**. The wheel locks will not grip properly if there is a broken or worn tire on the chair.

2. Axles & Axle Sleeves:

When checking axles and axle sleeves every six months, make sure they are clean and tight. Loose sleeves will damage the axle plate and will affect performance.

**C. CLEANING TIPS**

1. Paint Finish

- a. Clean the painted surfaces with mild soap or detergent at least once a month.
- b. Protect the paint with a coat of non-abrasive auto wax every three months.

2. Axles and Moving Parts

- a. Clean around axles and moving parts WEEKLY with a slightly damp (not wet) cloth.
- b. Wipe off or blow away any fluff, dust or dirt on axles or moving parts.

3. Upholstery

- a. Hand-wash (machine washing may damage fabric).
- b. Drip-dry only. DO NOT machine dry as heat will damage fabric.

4. Basic Maintenance Materials available at local store

- a. Tire Pump
- b. Clean rags or cotten cloth.
- c. Teflon-based Lubricant
- d. Mild Detergent.

**NOTE**– You do not need to grease or oil the chair.

**D. SAFETY CHECKLIST**

Weekly	3 Months	6 Months	Annually	Safety and Function Check
<input checked="" type="checkbox"/>				Tire integrity
<input checked="" type="checkbox"/>				Wheel locks
	<input checked="" type="checkbox"/>			Visually check for loose hardware
		<input checked="" type="checkbox"/>		Armrests
		<input checked="" type="checkbox"/>		Axle and axle sleeves
	<input checked="" type="checkbox"/>			Quick-release axles
	<input checked="" type="checkbox"/>			Wheels, tires and spokes
	<input checked="" type="checkbox"/>			Casters
	<input checked="" type="checkbox"/>			Anti-tip tubes
		<input checked="" type="checkbox"/>		Frame and crossbrace
	<input checked="" type="checkbox"/>			Upholstery
			<input checked="" type="checkbox"/>	Service by Authorized Supplier

**NOTE** - The user or caregiver should perform these weekly and monthly checks to maintain the safety of their chair. If an item is not working properly, please contact your authorized dealer to have the item(s) repaired before using the chair.

**E. TROUBLESHOOTING CHART**

Symptom						Solution
	Left turn in chair	Right Turn in chair	Looseness in chair	Sluggish turning	Squeaks and rattles	
<input checked="" type="checkbox"/>	<input checked="" type="checkbox"/>	<input checked="" type="checkbox"/>	<input checked="" type="checkbox"/>	<input checked="" type="checkbox"/>	<input checked="" type="checkbox"/>	Make sure tire pressure is correct and equal in both rear tires and front caster tires, if pneumatic.
		<input checked="" type="checkbox"/>	<input checked="" type="checkbox"/>	<input checked="" type="checkbox"/>	<input checked="" type="checkbox"/>	Make sure all nuts and bolts are tight.
		<input checked="" type="checkbox"/>	<input checked="" type="checkbox"/>	<input checked="" type="checkbox"/>		Make sure all spokes and nipples are tight on radial spoke wheels.
				<input checked="" type="checkbox"/>		Use Tri-Flow Lubricant (Teflon®-based) between frame connections and parts.
<input checked="" type="checkbox"/>	<input checked="" type="checkbox"/>		<input checked="" type="checkbox"/>		<input checked="" type="checkbox"/>	Check for proper caster fork adjustment. See instructions for caster fork adjustment.

## F. TO MOUNT & REMOVE REAR WHEELS 9 10

### WARNING

Do not use this chair **UNLESS** you are sure both quick-release axles are locked. An unlocked axle may come off during use and cause a fall.

**NOTE**— Setting the wheelchair on a flat surface, such as a workbench or table, helps make these procedures easier.

#### 1. To Install Wheel

- Depress quick-release button (A) fully. This will release tension on ball bearings (D) at other end.
- Insert axle (B) through hub of rear wheel.
- Keep button (A) depressed as you slide axle (B) into axle sleeve (C).
- Release button to lock axle in axle sleeve. Adjust axle if it does not lock.
- Repeat steps on other side.

**NOTE**— The axle is not locked until the quick-release button (D) pops out fully. Check that the axle is locked by pulling on the wheel in the direction of the axle.

#### 2. To Remove Wheel

- Depress quick-release button (A) fully.
- Remove wheel by sliding axle (B) completely out of axle sleeve (C).
- Repeat steps on other side.

## G. WHEEL LOCKS 11

### WARNING

Wheel locks are installed by the manufacturer and should be adjusted by your authorized dealer. Inspect wheel locks weekly per the maintenance chart. Do not use your chair **UNLESS** you are sure both wheel-locks can fully engage. A wheel-lock that is not correctly adjusted may allow your chair to roll, or turn unexpectedly. Wheel-locks must be adjusted after making sure the tires have the correct air pressure. When fully engaged, the wheel-lock arm (E) should be imbedded into the tire at least 1/8" to be effective.

**If you find the wheel locks have slipped or are not working correctly contact your service provider for proper adjustment.**

## H. ANTI-TIP TUBES

Sunrise Medical recommends anti-tip tubes for all wheelchairs.

#### 1. Inserting Anti-Tip Tubes Into Receiver 12

- Press the rear anti-tip release pin (F) on the anti-tip tube so that the release pin is drawn inside.
- Insert into the anti-tip tube receiver (G).
- Turn the anti-tip tube down until release pin is positioned through the receiver mounting hole.
- Insert second anti-tip tube the same way.

#### 2. Turning Anti-Tip Tubes Up 14

Turn anti-tip tubes up when being pushed by attendant, overcoming obstacles or climbing curbs.

- Press the rear anti-tip release pin (F) and pull rearwards on the anti-tip tube, in order to disengage the release pin.
- While the anti-tip tube is separated, rotate the anti-tip up 180° and release. Make sure the release pin engages correctly so that the anti-tip is locked in place.
- Repeat with second anti-tip tube.
- Return the anti-tip tubes to the down position after clearing the obstacle.

#### 3. Adjusting Anti-Tip Tube Wheel 13

The anti-tip tube wheels may have to be raised or lowered to achieve proper clearance of 1 1/2" to 2".

- With the thumb and forefinger, press the anti-tip wheel release pins (H) so that the release pins are drawn inside, and the anti-tip wheels can be moved.
- Raise or lower to one of the predrilled holes.
- Release pins. When the pins (H) are visible the anti-tip wheels are locked.
- Adjust the second anti-tip tube wheel the same way. Both wheels should be at exactly the same height.

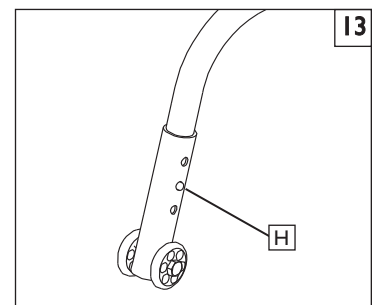
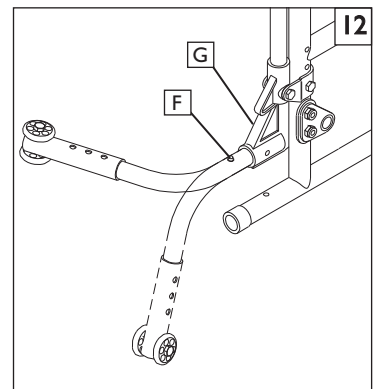
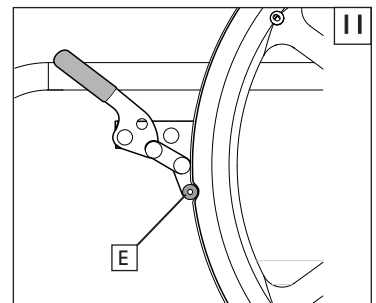
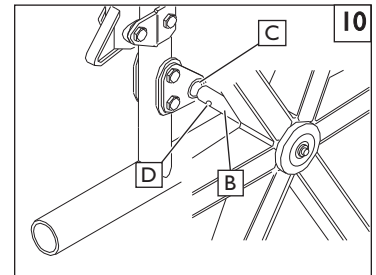
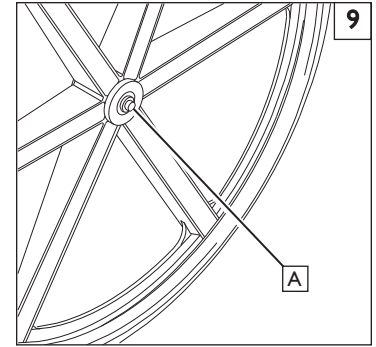

**I. ARMRESTS** 14

Sunrise medical offers two different types of armrests. Fixed, and Flip-back removeable. Flip-back armrests can be removed, or can flip-back to allow lateral transfers. The pads are height adjustable (1" increments) by pulling on the adjustment knob and moving the pad(I) up or down to the desired height.

**1. Fixed: Flipping-back the armrest**

- Release the front locking lever.
- Pull up and back to flip-back the fixed armrest (A) for clearance or transfers.
- To return the armrest to a locked position, rotate the armrest forward, and insert it into the front armrest receiver. The armrest should lock into place.

**2. Flip-back removeable: Armpad Height Adjustment**

- Release the height adjustment lever (2) to release the pad (1).
- Slide armpad up or down to desired height.
- Release the lever and move the armpad slightly until the release pin is in the locked position.

**3. Flip-back removeable: Flipping Armrest Back and Removing Armrest**

- Press the release lever (3) and pull arm toward back of wheelchair.
- To remove, lift the rear armrest post (4) off of the rear mount post (5).

**4. Flip-back removeable: Replacing Armrest**

- Lower the rear armrest post (4) to rear mount post (5) until it locks into place.
- Pull forward until the release lever (3) is locked into position in the armpost

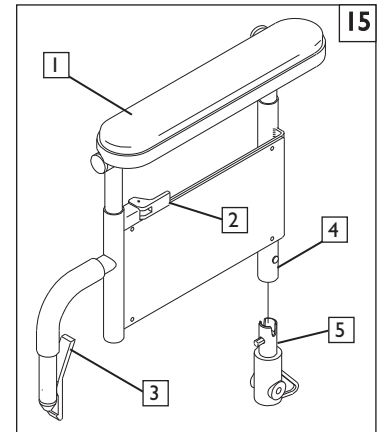
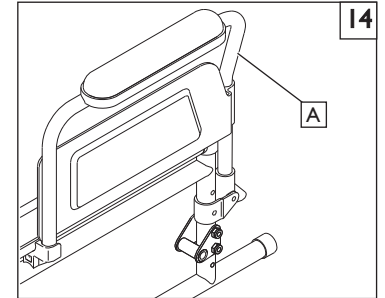
**J. SWING-IN / SWING-OUT HANGERS** 16 17

Make sure that your Authorized Dealer has correctly adjusted your footrests and/or legrests with the advice of a healthcare professional. The original setup should not be changed without first checking with your healthcare professional. The footrest position is key to keeping your body in the proper alignment, and providing a stable support for your legs and torso. Legrests and footrests should be swung out of the way, or removed for transfers.

**1. Basic Footrest Installation**

- Place the swing-in/swing-out footrest pivot (B) into the frame tube point (C) on the front frame tube with the footrest facing outward from the frame.
- Rotate the footrest inward until you hear it lock into place on the locking pin (D).

**2. Removal**

- To remove the footrest, push on the lever (E) to unlock.
- Rotate the footrest inward or outward and lift it off of the chair.

**3. ELR installation**

- Place the ELR footrest pivot into the front frame tube point with the footrest facing outward from the frame.
- Rotate the ELR inward until you hear it lock into place on the locking plate.
- Install the other side using the previous steps if needed.

**4. Elevating legrest adjustment**

- To adjust the elevating legrest, raise the legrest until the desired height is obtained.
- To re-position the legrest, support the leg with one hand and push the release Lever (F) downward with the other hand.
- To adjust the calf pad height, turn it towards the outside of the wheelchair and slide it up or down to one of the three pre-configured slots (G)

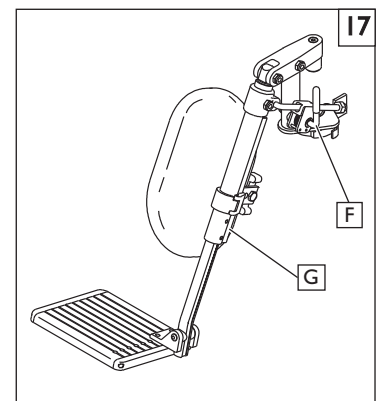
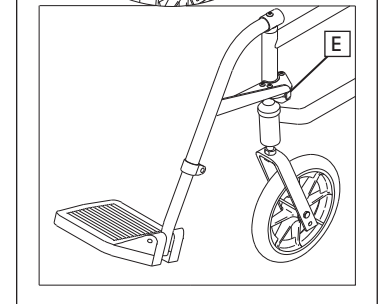
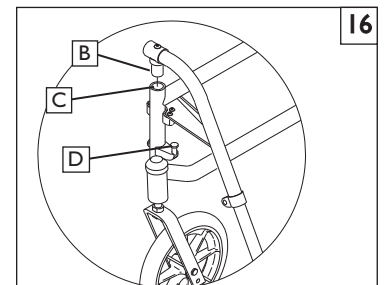

**K. SEATING AND SEAT SLING UPHOLSTERY** 18**⚠ WARNING**

The seat sling is not a seating surface. It is recommended that an appropriate wheelchair cushion be used with the wheelchair for proper protection of the skin and reduction in the possible occurrence of pressure sores that can develop when seated for long durations.

**1. Seat Sling Upholstery**

- a. Check monthly for excessive stretching of the upholstery, or loose attaching hardware. If you determine the upholstery can no longer be adjusted tight, contact your Authorized Dealer for a replacement.

**2. Cushion Installation**

- a. Place cushion on the seat sling with the hook material side down. The beveled edge of the cushion should be facing toward the front of your chair.
- b. If the bottom of your cushion has a loop material, you can use the two sided hook material provided (A) to attach to the sling as shown.
- c. Press the cushion firmly into place.

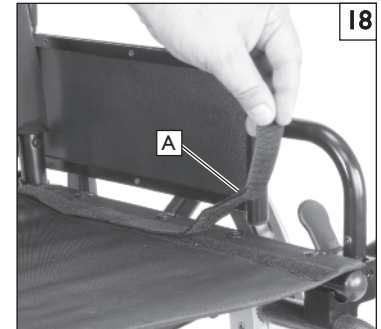
**L. FOLDING AND UNFOLDING** 19 20 21**⚠ WARNING****Possible pinch point! BE CAREFUL.**

1. If the seat sling is not present during folding and unfolding, hold the top of the seat rail securely without wrapping fingers around the seat rail.
2. Use flat palms (C) to depress the chair if you are opening or unfolding the chair.

**1. Folding the Wheelchair**

- a. Remove quick-release wheels (optional).
  - Depress quick-release button on the axle.
  - Remove wheel by sliding out quick-release axle from axle bracket.
  - Repeat with other wheel.
- b. Remove the footrests, or flip up the footplates before folding the wheelchair.
- c. Unhook the vanity flap(B) (underneath the seat sling).
- d. Grasp the seat sling (in the center) and lift sharply until the wheelchair is folded.

**2. Unfolding the Wheelchair**

- a. Replace quick-release wheel (optional) by depressing the quick-release button on the axle.
  - Slide it into the axle sleeve until it locks.
  - Repeat with other wheel.
- b. Tilt the wheelchair toward you far enough to take the weight off the opposite wheel.
- c. Push down on the seat rail(D) (closest to you) until the wheelchair is completely opened.
- d. Attach the Vanity Flap(B) (underneath the seat sling.)

**NOTE**– Ensure that footrests are down and locked prior to use.

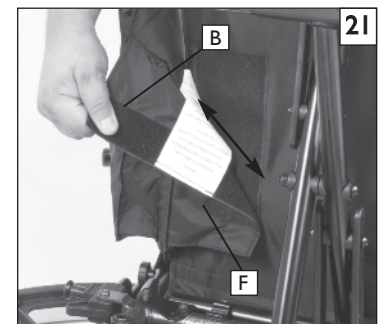
**M. STORAGE TIPS**

1. Store your chair in a clean, dry area. If you fail to do so, parts may rust or corrode.
2. Before using your chair, make sure it is in proper working order. Inspect and service all items on the "Maintenance Chart".
3. If stored for more than three months, have your chair inspected by an Authorized Dealer before use.

**N. CHECK-OUT**

After the wheelchair is assembled and adjusted, it should roll smoothly and easily. All accessories should also perform smoothly. If you have any problems, follow these procedures:

1. Review the set-up and check-out sections and operating guide to make sure chair was properly prepared.
2. Review troubleshooting guide.
3. If your problem persists, contact your Authorized Dealer. If you still have a problem after contacting your Authorized Dealer, contact Sunrise customer service. See the introduction page for details on how to contact your Authorized Dealer or Sunrise customer service.





## ⚠ WARNING

The owner of this chair is responsible for making sure that it has been setup and adjusted by a trained service professional under the advice of a healthcare advisor. Service and/or adjustments should only be done with the advice of a healthcare professional. Always use parts and/or accessories that have been recommended and approved by Sunrise Medical when servicing this chair.

### A. DEALER SERVICE INTRODUCTION 27

1. At least once per year, this chair should have a complete inspection, safety check, and regular service made by an authorized dealer. The tools at right are a good start for proper maintenance.
2. If you have discovered a worn, bent, or damaged part, repair or replace them with recommended parts **before returning this chair to service.**
3. All major maintenance and repair work should be done by the authorized dealer.

### B. CRITICAL MAINTENANCE TIPS

#### 1. Torque settings:

A torque setting is the optimum tightening which should be made on a particular fastener. It is important to use proper torque settings where specified. When not specified, torque settings should be 60 in-lbs

#### 2. Dealer Service and Adjustment Reference materials:

Go for parts manuals, instruction sheets, and instructional videos that will aid in the repair of the Breezy Family of wheelchairs.

### C. CLEANING

#### 1. Paint Finish

- a. Clean the painted surfaces with mild soap or detergent.
- b. Protect the paint with a coat of non-abrasive auto wax.

#### 2. Axles and Moving Parts

- a. Clean around axles and moving parts with a slightly damp (not wet) cloth.
- b. Wipe off or blow away any fluff, dust or dirt on axles or moving parts.
- c. **DO NOT USE** 3 in 1 oil, or WD-40® for lubrication. Only use Teflon based Lubricant when working on this wheelchair.

### D. STANDARD AND LOW FRONT SEAT HEIGHTS

Adjust seat height for body and mechanical efficiency. Be aware that a change in seat height may require a change in the size of the front caster stems or forks.

## ⚠ WARNING

If you raise the seat too high, you may "out-adjust" the caster forks. If this occurs, the seat will tilt too far forward, and puts the rider at risk of falling out of the chair. To avoid this, a longer caster fork or fork stem must be used to make the chair safe.

#### 1. Standard 18.5" (470 mm) front seat height:

- a. Remove the axle bolt.
- b. Attach the axle on the bottom adjustment hole(A) in the frame and tighten the axle nut to a torque of 150-175 in-lb (17-20 Nm).
- c. Repeat steps on the other side. Make sure both sides are the same height.

#### 2. Low 17.5" (445mm) front seat height.

- a. Remove the axle bolt.
- b. Attach the axle on the top adjustment hole(B) in the frame and tighten the axle nut to a torque of 150-175 in-lb (17-20 Nm).
- c. Repeat steps on the other side. Make sure both sides are the same height.

#### 3. Seat angle.

- a. Adjust to the proper Seat Height.
- b. After adjusting the Seat Height, you must adjust the Seat angle so that the front of the chair is slightly higher than the rear.
- c. Adjust the caster barrel height and angle to achieve the correct configuration.

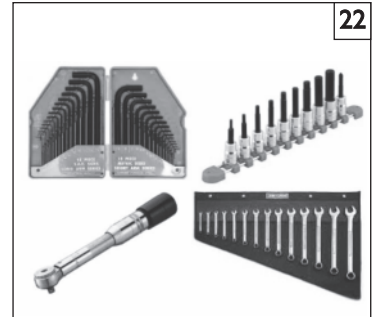

#### TOOLS YOU WILL NEED

1. Metric Hex key set
2. Metric Open-end Wrench set
3. Torque wrench
4. Metric Hex bit Socket set
5. Phillips and Flat screwdrivers

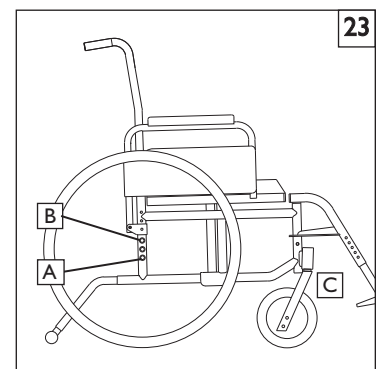

**E. REAR WHEEL AXLE NUT ADJUSTMENT** 24

Tight axle sleeves should be maintained for proper performance of the wheelchair.

- To adjust the axle (A) you will need a 19mm or (3/4") wrench (B) to turn the outside axle nuts (C).
- You will also need an 11mm or (1/2")wrench to lodge the ball bearings (D), on the opposite end of the axle, and prevent the axle from turning.
- Turn the outside axle nut (C) clockwise to tighten.
- There should only be zero to .25mm of play.
- Check to make sure that the quick-release button (E) is flush with the edge of the wheel.\

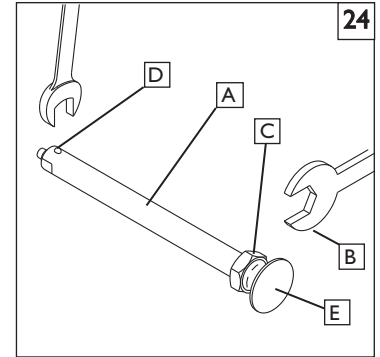
**F. WHEEL LOCK ADJUSTMENT** 25

Wheel locks are installed at the factory unless you have requested otherwise.

Use a torque setting of 115 in.-lbs. when setting up wheel locks.

**1. Forewards or rearwards wheel lock adjustment**

- Using a 6mm hex key, turn one of the screws (G) in the clamp counterclockwise one-quarter turn.
- Repeat the same process with the second of the two screws.
- Alternately loosen the screws (two turns each) until you can move the wheel lock.
- Slide clamp toward the rear wheel until the wheel lock is embedded into the tire to prevent wheel movement, when in the locked position.
- If the wheel lock needs more adjustment the wheel lock screws (F) can be loosened and the wheel lock can be adjusted another 2 inches either way.
- Be sure to adjust the other wheel lock in the same manner.
- Tighten screws to 115 in.-lbs.

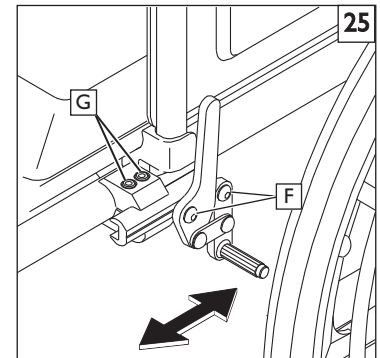
**2. Wheel Lock angle adjustment**

- Using a 6mm hex key, loosen the screws (A) in the clamp until the wheel lock can be rotated.
- Repeat the same process with the other wheel lock.

**NOTE** - Use a torque of 115in.-lb. Clamp and wheel lock may need to be rotated to clear frame tubing.

**G. CASTER FORKS** 26

Two-hole caster forks allow the adjustment of seat height and/or seat angle.

**1. Standard 18.5" (470 mm) front seat height:**

- Remove the caster wheel bolt (J) and bearing spacers (not shown).
- Move caster into the bottom fork adjustment hole (H) in the frame.
- Replace the caster wheel bolt and bearing spacers and and tighten the bolt to 75 in-lb (17-20 Nm).
- Repeat steps on the other side. Make sure both sides are the same height.

**2. Low 17.5" (445mm) front seat height.**

- Remove the caster wheel bolt (J) and bearing spacers(not shown).
- Move caster into the top fork adjustment hole (I) in the frame.
- Replace the caster wheel bolt and bearing spacers and and tighten the bolt to 75 in-lb (17-20 Nm).
- Repeat steps on the other side. Make sure both sides are the same height.

**3. Seat angle.**

- Adjust to the proper Seat Height.
- After adjusting the Seat Height, you must adjust the Seat angle so that the front of the chair is slightly higher than the rear.
- Adjust the caster barrel height and angle to achieve the correct configuration.

Use a torque setting of 75 in.-lbs. when adjusting the casters.

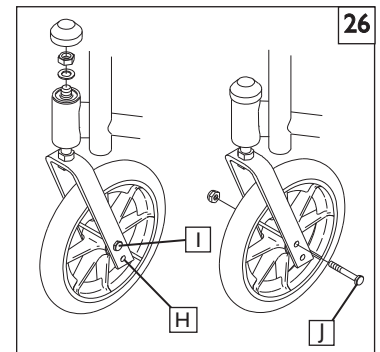

**H. CASTERS** 27 28

**NOTE** - Setting the wheelchair on a very flat table or a workbench makes this setting more accurate.

**NOTE ON TORQUE SETTING** - A torque setting is the optimum tightening which should be made on a particular fastener. Use proper torque settings when specified.

**1. Check for caster squareness**

Your Breezy wheelchair leaves the factory with the casters adjusted square. Any time you change your wheelchair rear axle height, rear tire size, or center of gravity position, you should check that the casters are still square. A caster that is not square will result in the caster lifting off the floor as it rotates around the stem bolt and may also lift the front of the wheelchair up and down. Check for squareness by placing your wheelchair on a flat, horizontal surface. Rotate both forks so that the casters are towards the rear of the wheelchair. Place a square or pocket level against the flat surface on the rear of the fork and note whether this surface is vertical (square) . If this surface is more than 2 degrees away from vertical, your casters require re-squaring.

**2. Caster journal angle adjustment**

- Loosen the hardware so the the eccentric nuts (A) can be adjusted.
- Using a large right triangle against the table surface and the front surface of the caster housing (B) this will align the caster stem rotational axis perpendicular to the floor surface.
- Adjust the caster so that it is square. and make sure the eccentric nuts are seated correctly.  
Tighen the hardware to a torque of 50-65 in-lbs (5.6-7.3nm).
- Repeat this process for the other side.

**3. Caster mounting (forward or rearward placement)**

- Remove the two eccentric bolts from each caster.
- Move the Left-side caster to the right side, and the right-side caster to the left side.
- Remount the caster plate to the caster bracket.
- Make sure the eccentric nuts are seated correctly, and the caster housings are square  
Tighen the hardware to a torque of 50-65 in-lbs (5.6-7.3nm).
- Make sure that both sides have the same angle and position adjustments before use.

**I. FOOTREST HEIGHT ADJUSTMENT** 29

It is important that the footrest is the proper height for the rider, adjust for support and comfort.

- To adjust the height of the footrest, remove the screw and washer (C).
- Make sure the hardware insert (D) remains in the top of the tube
- Slide the footrest up or down in the adjustment tube to find the correct height out of the 5 adjustment holes(E)
- Align the Insert hole (D) with the adjustment holes(E) by inserting a hex key or small screwdriver all of the way through the hole and insert the screw and washer (C)
- Lightly tighten the hardware making sure it is not cross-threaded and finish tightening.
- Check to make sure that the footrest is secure before using the wheelchair.
- Repeat the steps for both footrests. In most cases you will have to make sure the other footrest is set to the same height.

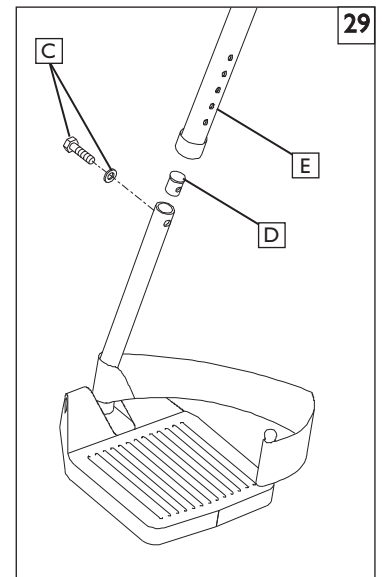
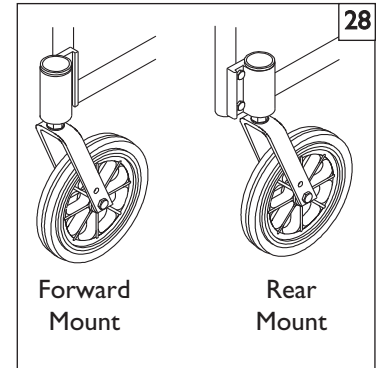
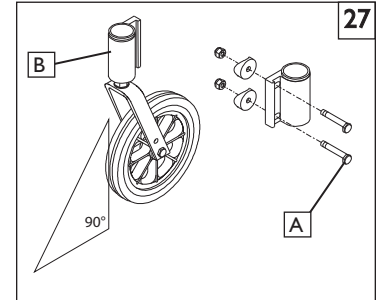

**J. SEAT SLING REPLACEMENT****I. Removal and installation**

1. Using a 4mm hex key, remove the eight seat sling screws
2. Exchange the old sling for the new sling.
3. Replace the seat sling screws.

**K. BACKREST UPHOLSTERY REPLACEMENT****I. Removal and Installation**

1. Using a 4mm hex key, remove the two back upholstery screws
2. Exchange the old upholstery for the new upholstery.
3. Replace the back upholstery screws.

**L. BACKREST** 30**I. Height Adjustment**

- a. Remove the backrest material
- b. There are four holes, 1" apart, in each backrest tube (A). The tube telescopes into the frame and is secured by a bolt on the side of the frame. Choose one of the four holes (A) to set the back height.
- c. Remove bolt(B) from each backrest tube.
- d. After selecting the proper height, slide the backrest upholstery onto the back canes.

**NOTE** - Do not attach the overlap portion, use a torque setting of 75 in-lbs. when adjusting backrest.

- e. Insert the nylon tie (E) through the grommets (F). Secure the tie and cut the excess zip tie to complete the adjustment.

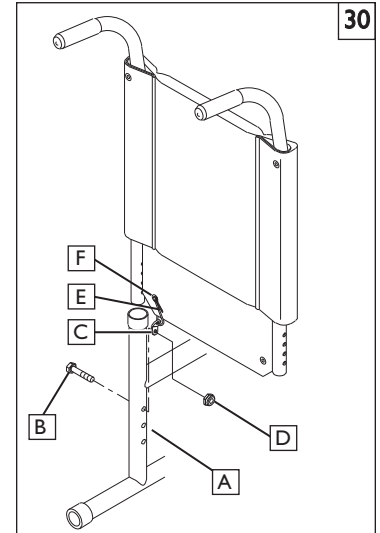



**A. FOR LIFETIME**

Frame and cross-brace (if applicable) warranty:

1. Although the anticipated useful service time of this wheelchair is five years, Sunrise guarantees the frame and cross brace against defects in material and workmanship for life or for as long as the original purchaser owns the chair.
2. This warranty does not apply if:
  - a. The chair is subject to abuse
  - b. The chair is not maintained as recommended in the owner's manual
  - c. The chair is transferred to a different person from the original owner

**B. FOR ONE (1) YEAR**

We warrant all Sunrise-made parts and components of this wheelchair against defects in materials and workmanship for one year from the date of first consumer purchase..

**C. LIMITATIONS**

1. We do not warrant:
  - a. Tires and tubes, upholstery, pads and push-handle grips.
  - b. Damage from neglect, accident, misuse, or from improper installation or repair.
  - c. Products modified without Sunrise Medical's express written consent.
  - d. Damage from exceeding the weight limit.
2. This warranty is VOID if the original chair serial number tag is removed or altered.
3. This warranty applies in the USA and Canada only. Check with your supplier to find out if international warranties apply.
4. This warranty is not transferable and only applies to the first consumer purchase of this wheelchair through an authorized Sunrise Medical dealer.

**D. WHAT WE WILL DO**

Our sole liability is to repair or replace covered parts. This is the exclusive remedy for consequential damages.

**E. WHAT YOU MUST DO**

1. Obtain **from us**, while this warranty is in effect, prior approval for return or repair of covered parts.
2. Return the wheelchair or part(s), freight pre-paid, to Sunrise Medical at: 8401 Bearing Drive, Indianapolis, IN 46268.
3. Pay the cost of labor to repair, remove or install parts.

**F. NOTICE TO CONSUMER**

1. If allowed by law, this warranty is in place of any other warranty (written or oral, express or implied, including a warranty of merchantability, or fitness for a particular purpose).
2. This warranty gives you certain legal rights. You may also have other rights that vary from state to state, or province.

**G. ADDITIONAL WARRANTY INFORMATION**

For goods provided by Sunrise Medical Pty Ltd in Australia, our goods come with a guarantee by Sunrise that cannot be excluded under the Australian Consumer Law. You are entitled to a replacement or refund for a major failure and for compensation for any other reasonably foreseeable loss or damage. You are also entitled to have the goods repaired or replaced if the goods fail to be of acceptable quality and the failure does not amount to a major failure. The benefits to you given by this warranty are in addition to your other rights and remedies under a law in relation to the goods to which the warranty relates.

Record your serial number here for future reference:

---

