

# Klip Posterior Gait Trainer Accessories User Manual

Forearm Platform:  
**KP800S & KP800L**

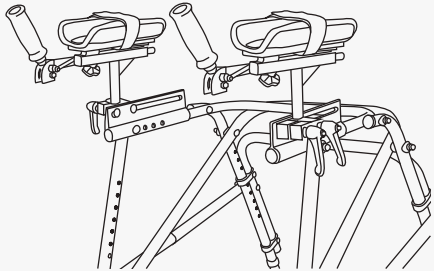

Sling Seat:  
**KP810S & KP810L**

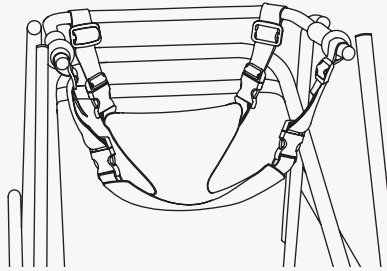

Pelvic Stabilizer:  
**KP820**

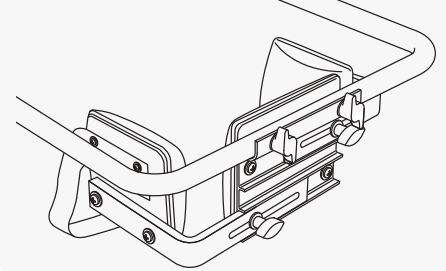

Thank you for purchasing the  
**Klip Posterior Gait Trainer Accessories!**

Please read these instructions carefully before assembling  
or using the Klip Gait Trainer or any of its accessories.

Save these instructions for future reference.

The Klip walker must be securely locked into the  
open position before installing the accessories.

**NOTE: All adjustments are tool-free for your convenience**

## Forearm Platform: KP800S & KP800L

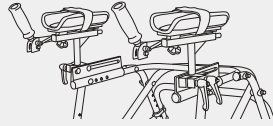

The Klip **Forearm Platform** consists of a mounting bracket and contoured armrest with handgrip.

### INSTALLATION

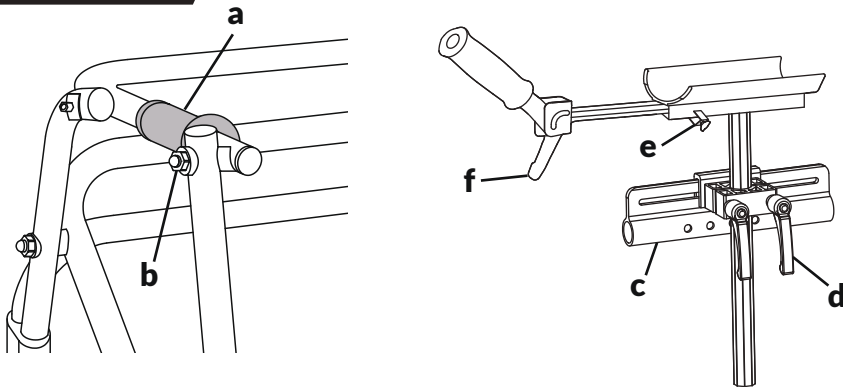

1. Remove handgrips **(a)**. Carefully make a cut along the handgrip with a knife and remove from handlebar.
2. Remove front bolt assembly **(b)**.
3. Slide mounting bracket **(c)** onto handlebar with the mounting bracket ratchets facing the outside of the Klip gait trainer frame.

There are 4 positioning holes on the mounting bracket. Determine forward/backward position of mounting bracket, align appropriate adjustment hole with Klip frame and install bolt assembly. Bolt head should be facing inside the Klip gait trainer frame.

### ADJUSTMENTS

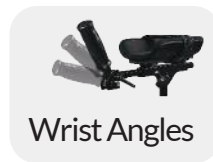
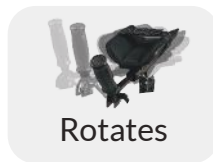
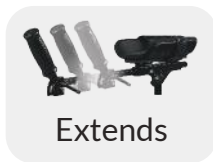

Forearm platform height, depth and rotation adjustments are achieved by loosening the two ratchet handles **(d)**, setting forearm platform at desired configuration and tightening ratchets.

Handgrip depth and rotation adjustment are achieved by loosening knob **(e)** on the underside of forearm armrest, adjusting the handgrip and tightening the knob.

Wrist angle is achieved by loosening ratchet handle **(f)**, adjusting the handgrip and tightening the ratchet handle.

## Sling Seat: KP810S & KP810L

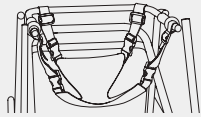

### INSTALLATION

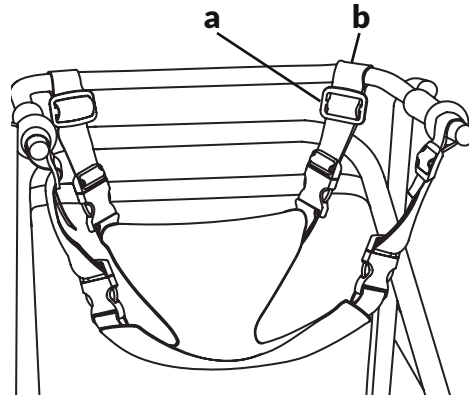
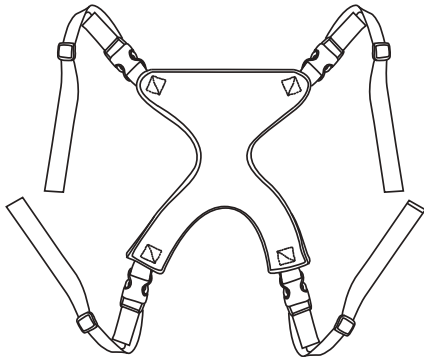

1. The flat edge of the sling seat should be placed at the rear of the gait trainer with the adjustable side-release buckles **(a)** underneath the seat.
2. Position the rear straps underneath and over the frame and loop the straps through the buckle **(b)**.
3. Position the front straps underneath and over the frame and loop the straps through the buckle.

### ADJUSTMENTS

To properly adjust sling seat, lengthen or shorten the straps.

## Pelvic Stabilizer: KP820

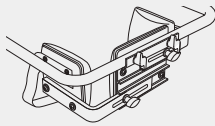

### INSTALLATION

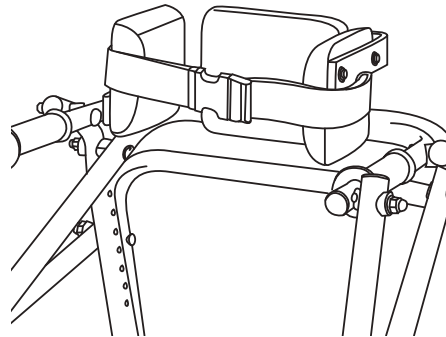
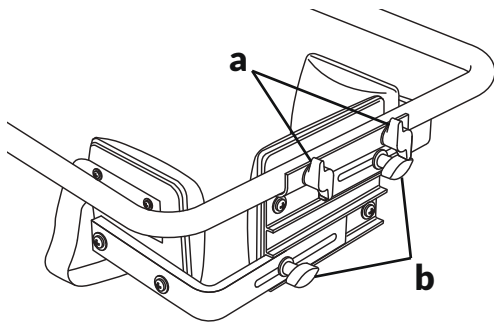

1. Position the pelvic stabilizer under or over the handlebar tube and align the pelvic stabilizer and handlebar holes.
2. Insert the bolts (**a**) and tighten.

### ADJUSTMENTS

**Width Adjustment:** Loosen the two knobs (**b**) on the back of the pelvic stabilizer and position the two side pads to desired configuration.

**Height:** The pelvic stabilizer can be mounted either below or above the handlebar for height adjustment.

To adjust the support belt, slide the strap through the buckles and adjust to the length required.

#### One Year Warranty

This warranty is solely for the benefit of the original consumer purchaser and is in effect from date of purchase.

Circle Specialty Inc. warrants that the Klip walker frame will be free from defect for a period of one (1) year.

The warranty does not extend to non-durable components, such as, rubber accessories and grips.

This warranty does not cover device failure due to owner misuse or negligence. It only applies when product is used according to the specified conditions and for the intended purposes.

If within the warranty period any such product shall be proved defective, such product will be repaired or replaced at Circle Specialty's option.

If you have a question about your Circle Specialty wheelchair or this warranty, please contact an authorized dealer.