

Ziggo Wheelchair Accessories User Manual

Headrest:
ZGTH01

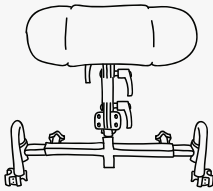

Trunk Harness:
ZGTH01

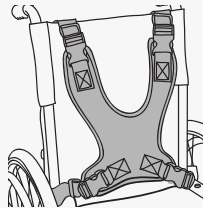

Anti-Tipper:
ZGAT01

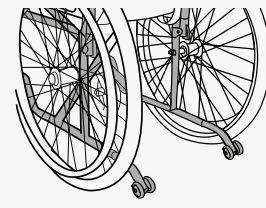

Elevating Legrest:
ZGELR01, ZGELR02

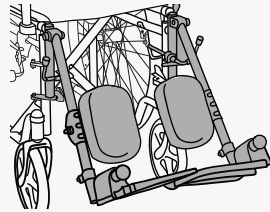

Cushion:
ZGCS12, ZCCS14, ZGCS16



Thank you for purchasing the
Ziggo wheelchair and accessories.

The wheelchair accessories are designed to increase
comfort and improve support and mobility.

Accessories can be purchased based on your requirements.

*Installation is simple, giving you the ease to
remove or add accessories as required.*

INSTALLATION

TRUNK HARNESS:

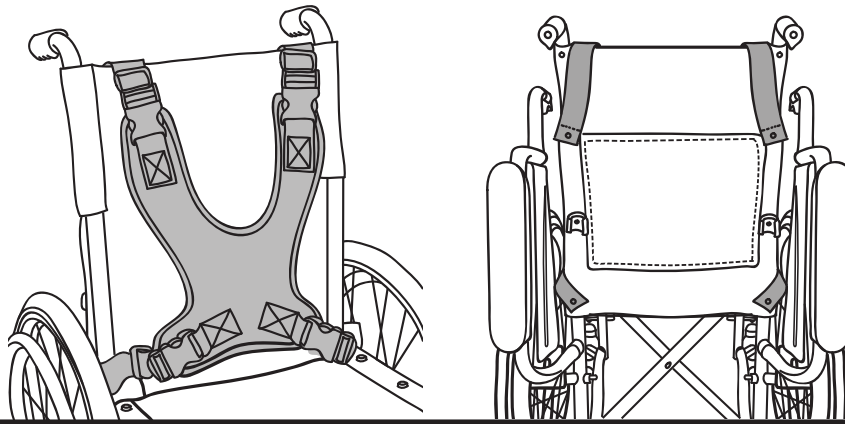

Place adjustable top straps over the top edge of wheelchair back. Remove second screw and tapered washer from back cane, thread screw through rivet on strap and reinstall.

Lift armrests and wrap bottom adjustable straps around the back canes. Remove lowest screw and tapered washer from the back cane, thread screw through rivet on strap and reinstall.

Stand behind user and pull finger loops to adjust straps. The quick release buckles allow quick entry and exit.

ELEVATING LEG RESTS:

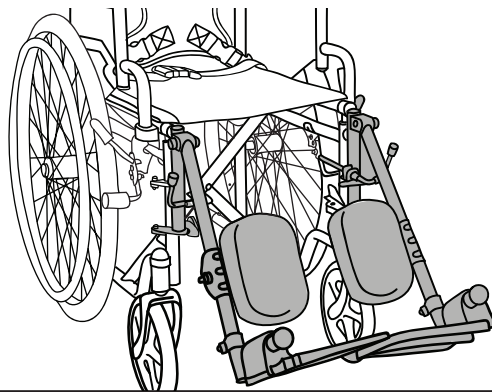

While sitting in the wheelchair, adjust the leg rest to required height &/or angle.

Height – Press in push pins and raise/lower footplate to desired position. The footrest should not be lowered to the point that it causes pressure on the thighs at the front of the seat upholstery. It should not be closer than 2.5” from the ground in order to ensure proper

Angle – Lift leg rest to desired angle and release. It will automatically lock into place. To lower, push down leg rest release lever and lower leg rest to desired angle.

Calf Pad Height – Turn calf pad until bracket is released of pin and raise/lower to desired position.

ANTI-TIPPERS:

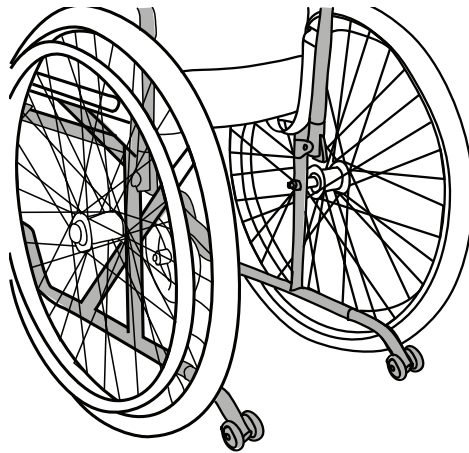

Remove rubber tips from side frame and insert anti-tippers into the side frame until anti-tipper release button clicks into place.

HEADREST:

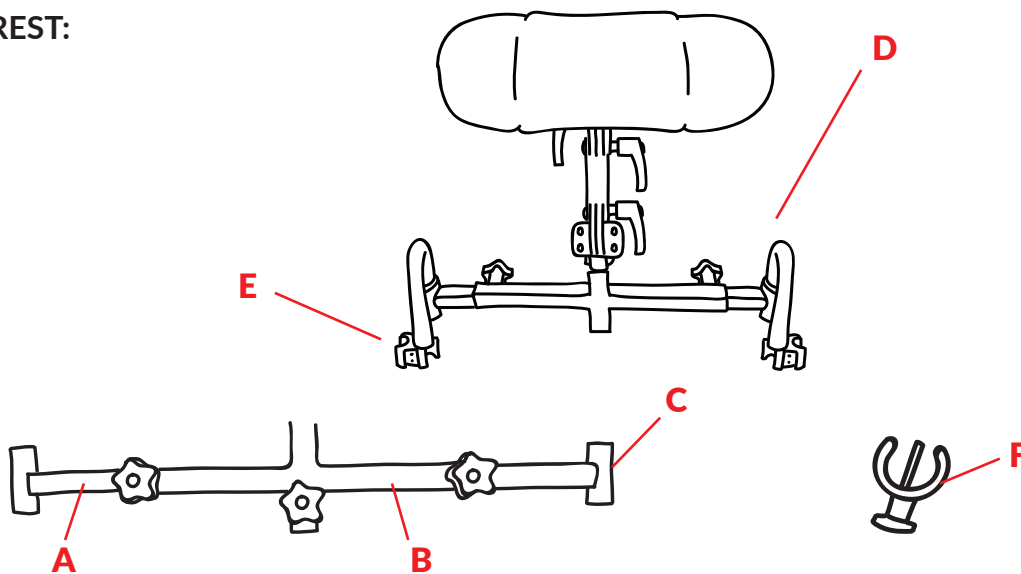

1. Insert telescoping side (A) into main bar (B). the knob of the main bar should be facing downwards and the hole on the round tube (C) should be facing you and upwards.

2. Insert short side of U bar (D) into round tube (C) and make sure U-tube hole lines up with round tube hole. Insert pin clip (F) and secure.
3. Loosen bolts on both clamps (E) and insert long side of U bar (E) into clamps. Do not tighten.
4. Mount back side of clamps onto back canes of wheelchair and tighten bolts.
5. Insert top headrest section into square tube and tighten all knobs.
6. Adjust headrest pad by loosening ratchet handle and finding proper position. Tighten ratchet handle.

Limited 1 Year Warranty

This warranty is solely for the benefit of the original consumer purchaser and is in effect from date of purchase.

Circle Specialty Inc. warrants that the Ziggo Wheelchair Accessories will be free from defect for a period of one (1) year. This warranty does not cover device failure due to owner misuse or negligence. It only applies when product is used according to the specified conditions and for the intended purposes.

If within the warranty period any such product shall be proved defective, such product will be repaired or replaced at Circle Specialty's option.

If you have a question about your Circle Specialty wheelchair or this warranty, please contact an authorized dealer.