

Adjusting 45° Compass® Hardware Including 4-Point

Compass® Hardware - US Patent No. 7,104,610 & 7,891,739 Apparatus for Mounting a Wheelchair Back

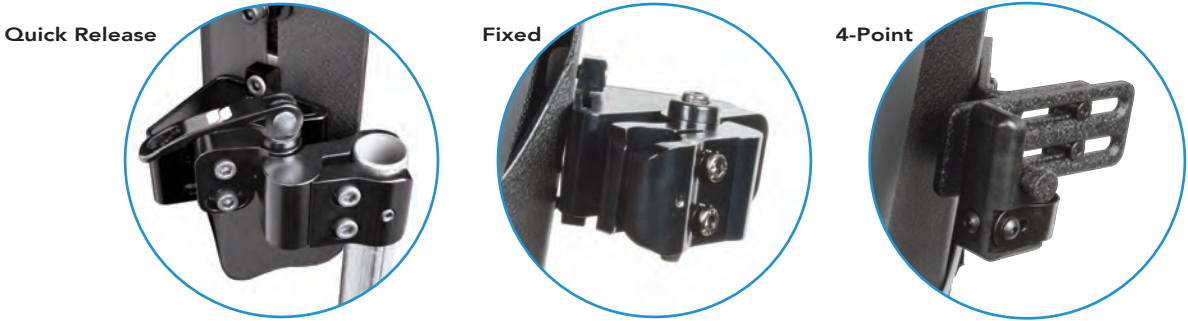

The information in this manual was gathered and recorded with the latest specifications available at the time of publication. Due to our continued effort to reassess and improve our products, information found in this manual such as drawings and notes may vary slightly from the product that you purchased. We reserve the right to make changes to products as they are deemed necessary.

Depth Adjustment

- Standard Configuration (as shipped)
- Flipped Cane Clamp
- Flipped Cane Clamp **and** Cam Latch Bracket
- Cane Tube Center Line

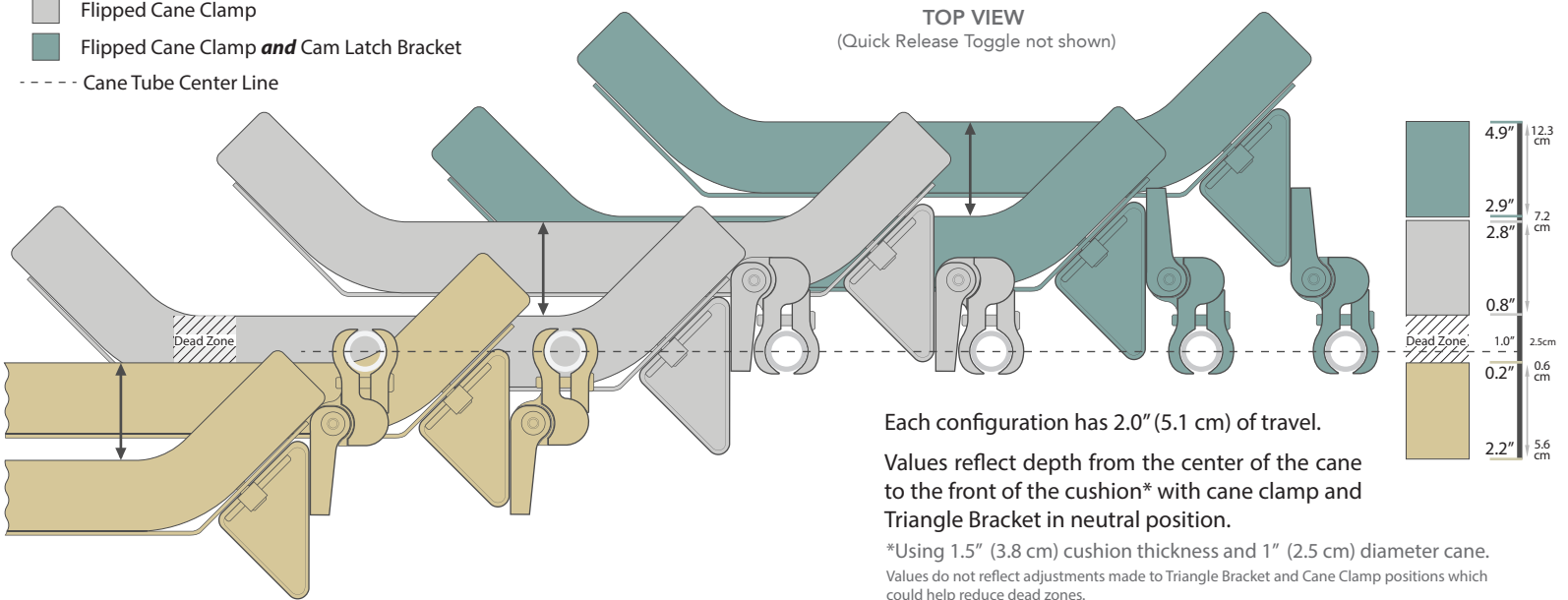

Width Adjustment

Standard Hardware Configuration Shown

TOP VIEW
(Quick Release Toggle not shown)

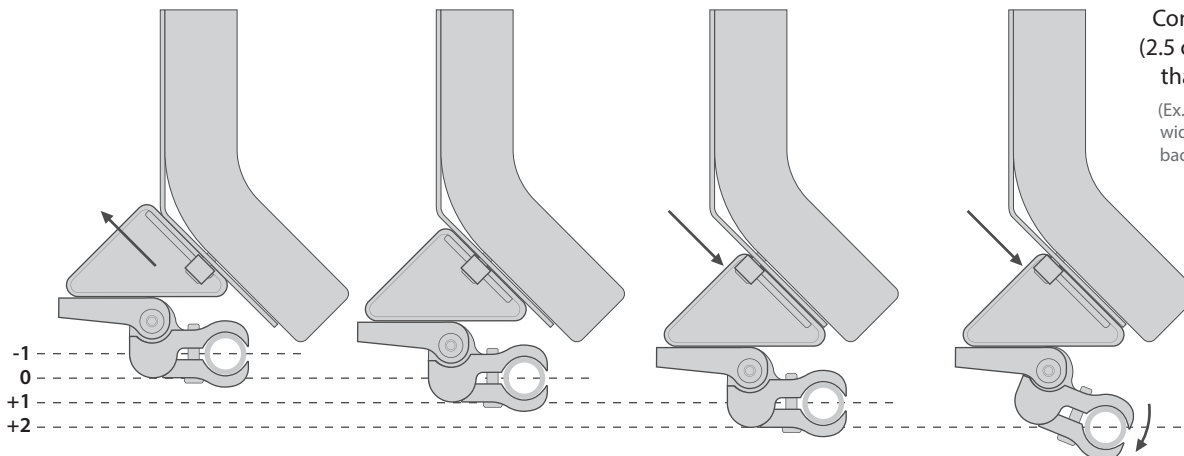

Compass® is width adjustable to 1" (2.5 cm) narrower or 2" (5.1 cm) wider than the ordered backrest width.

(Ex. An 18" wide backrest will fit a 17" to 20" wide wheelchair frame when both sides of backrest hardware are adjusted as shown.)

Angle Adjustment

Standard Hardware Configuration Shown

SIDE VIEW
(Quick Release Toggle not shown)

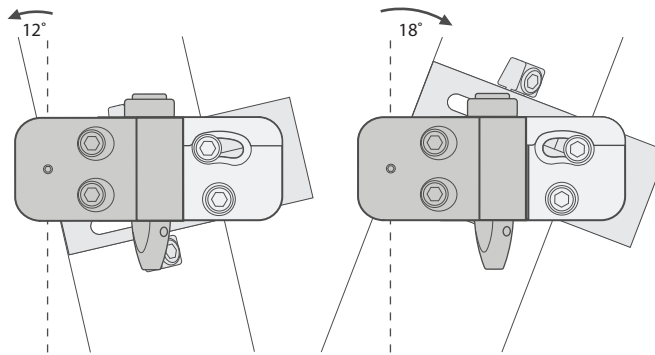

Compass® hardware provides 30° total anterior to posterior tilt.

NOTE: Flipping the hardware to the configuration seen in Section 3 will reduce the amount of possible posterior tilt to 12° and increase anterior tilt to 18°.

SECTION 1: INITIAL DEPTH MEASUREMENT

- 1.0** Using Figure A as a guide, determine approximately how much distance you desire from the front surface of the back cushion and the center of the cane tube. Measure from the dot (●) level with the center of the cane tube to the square (■) on the front of the cushion. If the cushion (■) is in front of the cane (●), use a positive value. If the cushion (■) is behind the cane (●), use a negative value.

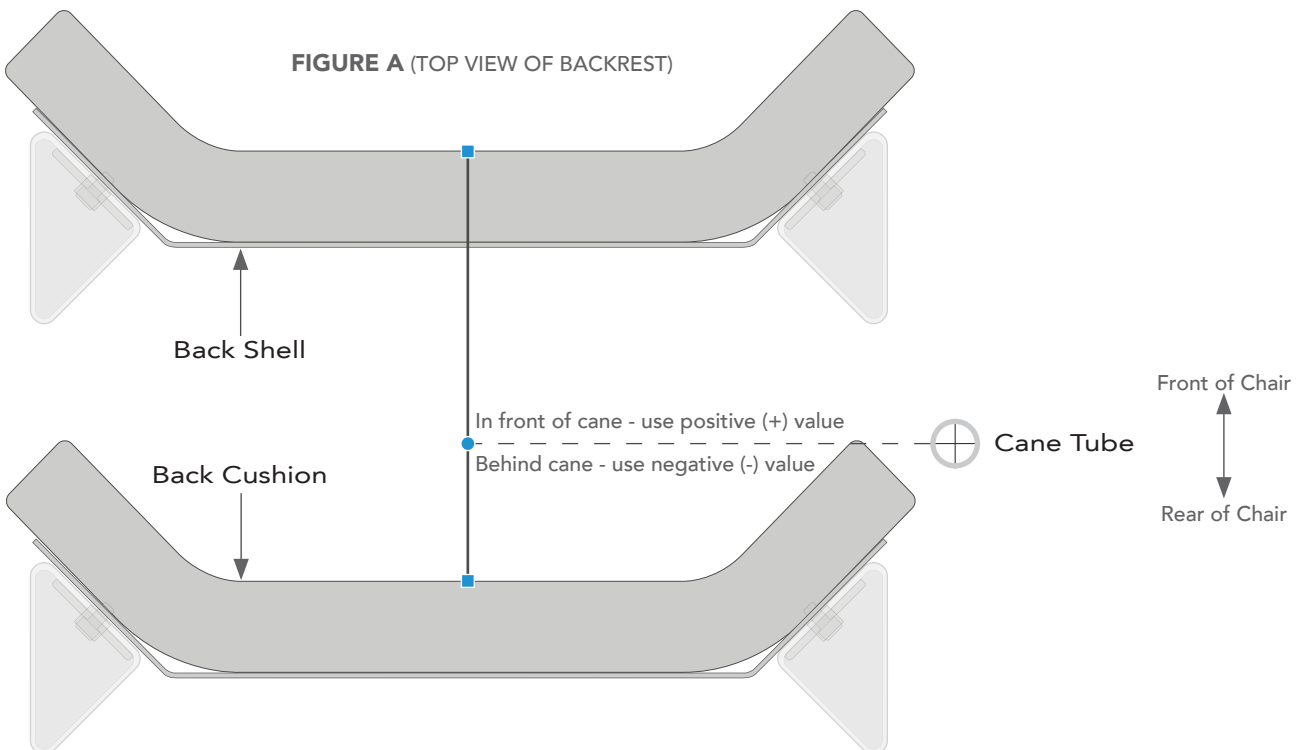

- 1.1** Find the range listed below that your measurement fits into. If it does not fall within a range listed, choose the one closest to your measurement. Adjustments to the Triangle Bracket position or rotating the Cane Clamp may still allow you to reach your desired depth.

For **-2.2" to -0.2"** (-5.6 cm to -0.6 cm), continue with Page 3, Section 2

For **+0.8" to +2.8"** (+2.1 cm to +7.2 cm), skip to Page 5, Section 3

For **+2.9" to +4.9"** (+7.2 cm to +12.3 cm), skip to Page 7, Section 4

NOTE: Measurements are based on commonly used 1.5" (3.8 cm) thick cushion. Cushion thickness could vary depending on the size and kind of backrest. Adjust dimensions accordingly for your backrest.

SECTION 2

- 2.0** You will need to use the following hardware configuration (Figure B) to achieve your desired back position. This is the standard configuration for 45° Compass® Hardware (how it was shipped).

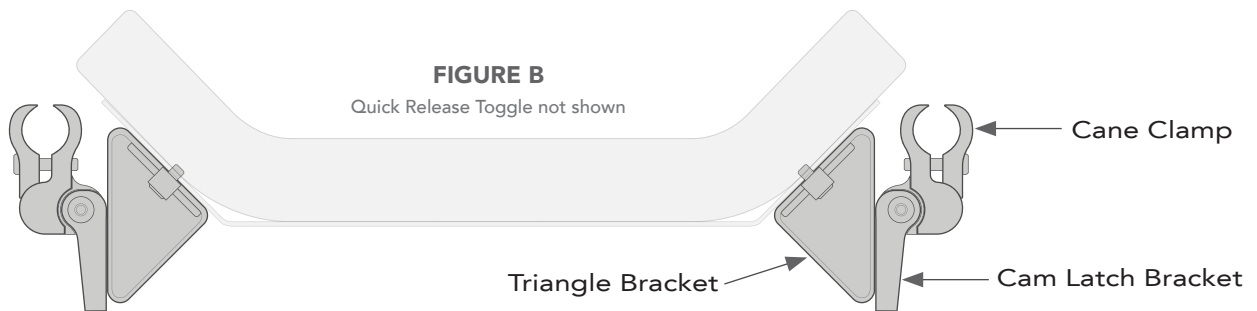

- 2.1** Start by determining that the left and right Triangle Brackets are located at the same height on the back shell (Figure C). The Triangle Brackets should always be at equal height on the back shell and level for best results. The Triangle Bracket and Cane Clamp angle allow for width adjustments to be made if using a chair that is different from the ordered backrest width.

To make adjustments to the bracket position, loosen (do not remove) the bolts above and below the Triangle Bracket using a 5mm hex key. Slide the bracket into place and tighten the bolts to secure.

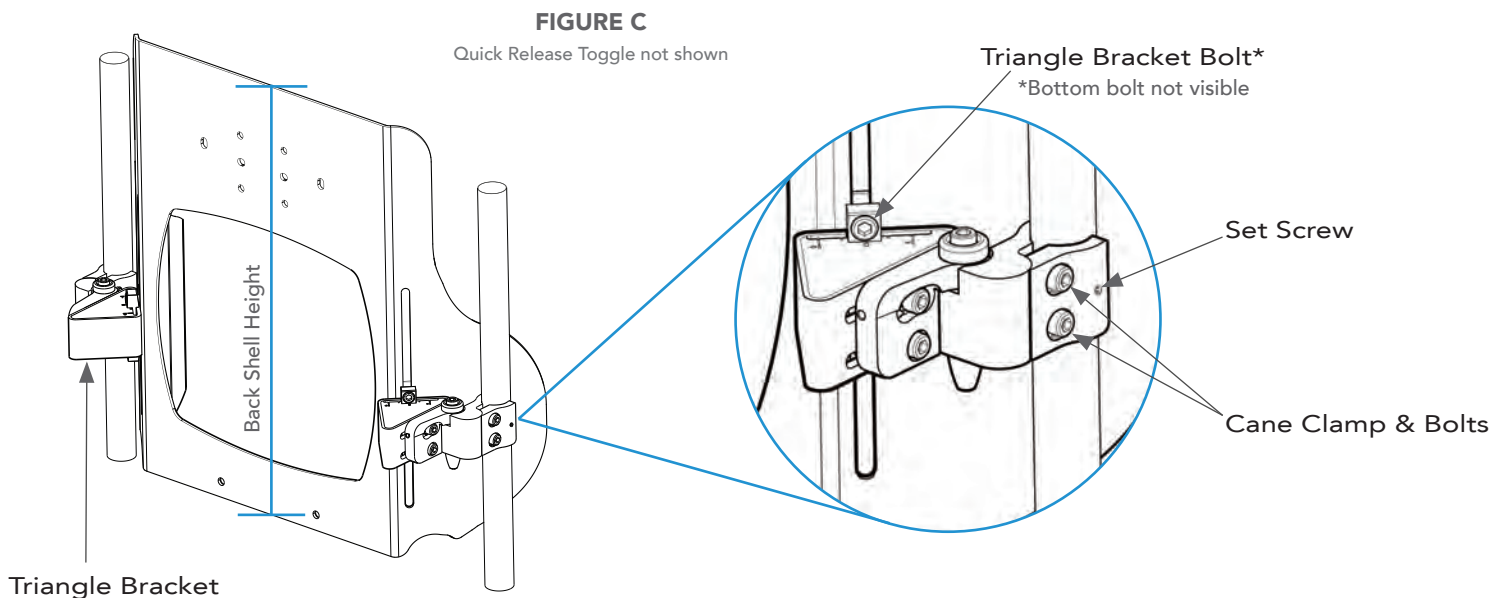

- 2.2** Next, loosen the 2 bolts on the Cane Clamp. Fit the clamp around the cane at equal height and tighten the bolts to secure. Alternate between bolts multiple times while tightening to ensure even pressure and a square fit. Complete this step for each side of the backrest. Finish by tightening the Set Screw on each clamp.

2.3 To adjust to your desired seat depth, use 5mm hex key and loosen (do not remove) the 2 bolts located in the Cam Latch Bracket on each side of the backrest. Figure D

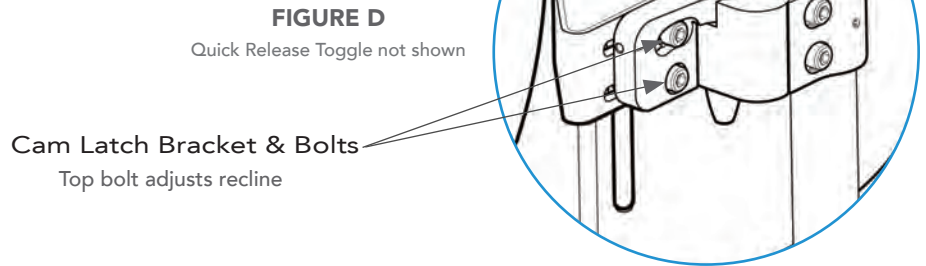

Once loose, slide the Cam Latch Bracket forward or backwards on the Triangle Bracket as seen in Figure E. Sliding it forward will achieve up to 2.2" (5.6 cm) of depth behind the cane tube and backwards will reach up to 0.2" (0.6 cm) of depth behind the cane tube.

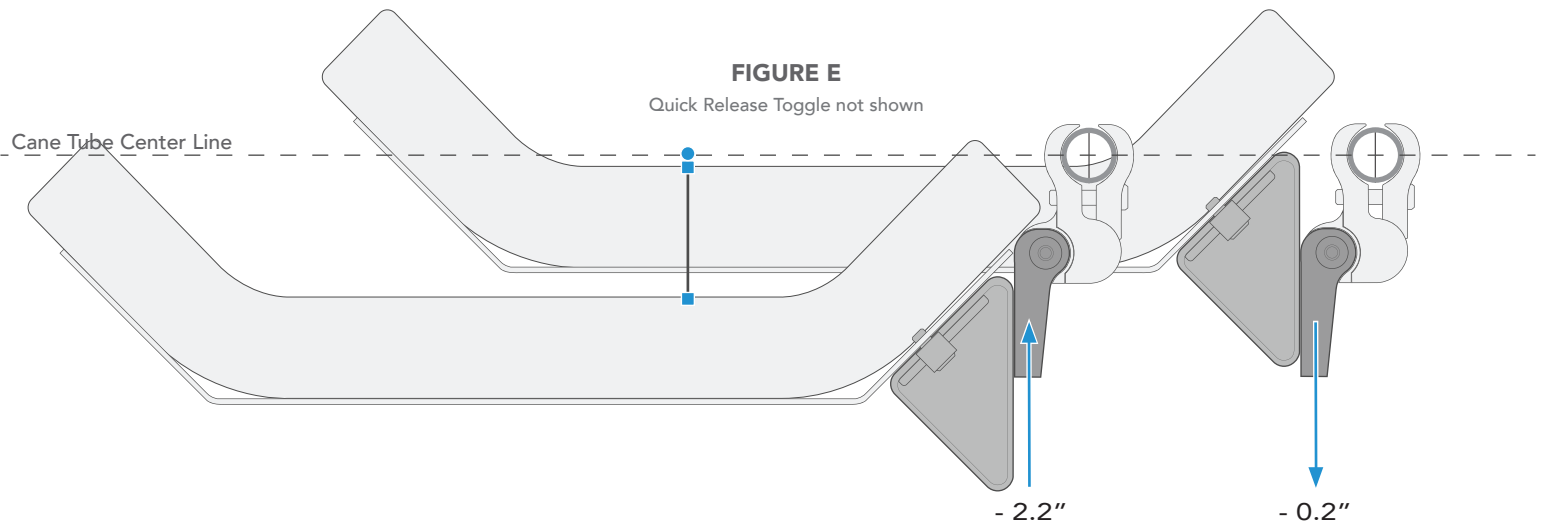

2.4 The top bolt located in the Cam Latch Bracket controls the backrest recline. Fasten the bottom bolt first but do not tighten completely before setting the recline. Posterior tilt may cause some loss in seat depth so the bottom bolt may have to be loosened and readjusted before final tightening can occur.

Once the seat depth is adjusted accordingly, tighten the Cam Latch Bracket bolts on both sides of the chair. Alternate between bolts multiple times while tightening to ensure even pressure.

Note: If adjustments are needed to the Triangle Bracket position (Figure F) to achieve the greatest range of positioning, always make sure the Triangle Bracket is at a position where the chair canes are relaxed and the bracket is level to the backrest.

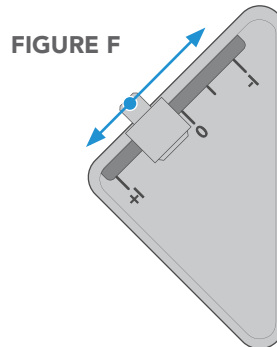

IMPORTANT: When installation and adjustments are complete, all bolts* should be tightened to a minimum of 85 in-lbs.
*This does not include set screws.

SKIP TO SECTION 5 FOR 4-POINT HARDWARE INSTRUCTIONS IF NEEDED

SECTION 3

- 3.0** You will need to use the following hardware configuration (Figure G) to achieve your desired back position. This flips only the Cane Clamps around to the opposite side of the chair.

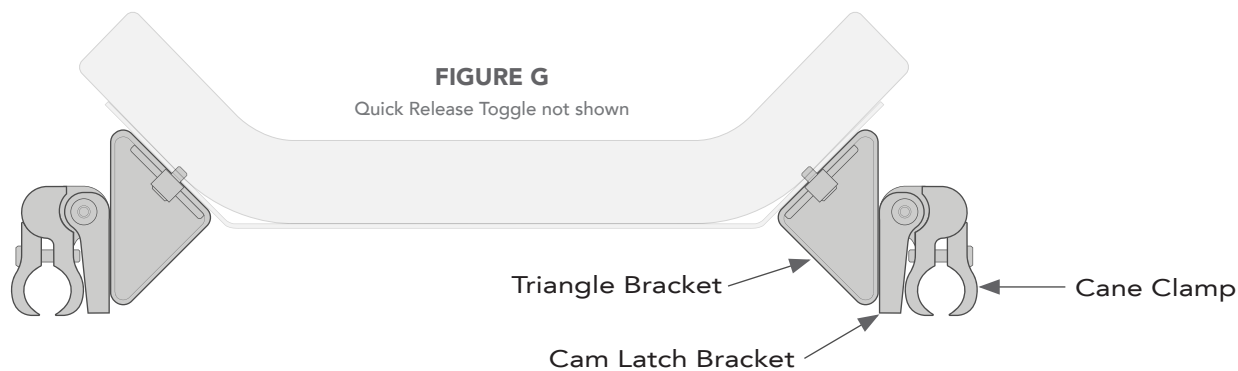

- 3.1** To switch the Cane Clamp around, release the Cam Latching system.

Quick Release Compass® hardware uses a toggle lever. Pull the lever up and the Cam Latch Bracket will slide apart from the Cane Clamp easily. (Figure H)

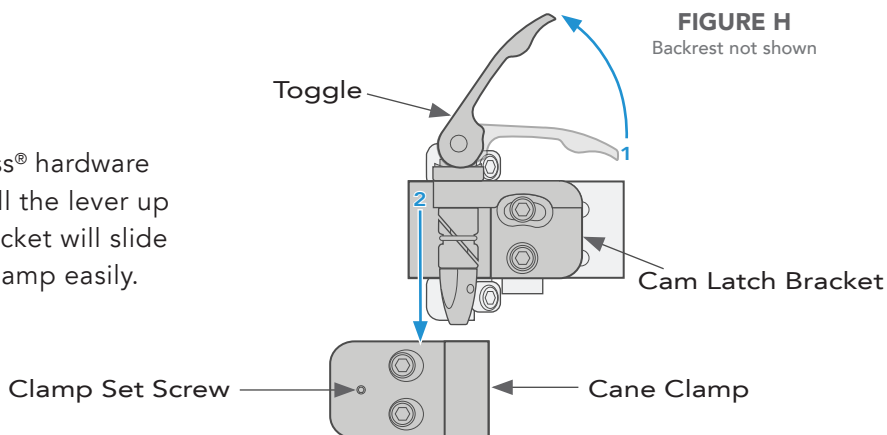

Fixed Compass® hardware uses a 5mm bolt to secure the Cane Clamp. To release the bolt, first unscrew the 2 mm Set Screw one full turn (Figure J). Then use an 11mm open-end wrench around the cam latch Cone and a 5mm hex key to loosen the bolt. Once loosened, the Cam Latch Bracket will slide apart from the Cane Clamp easily.

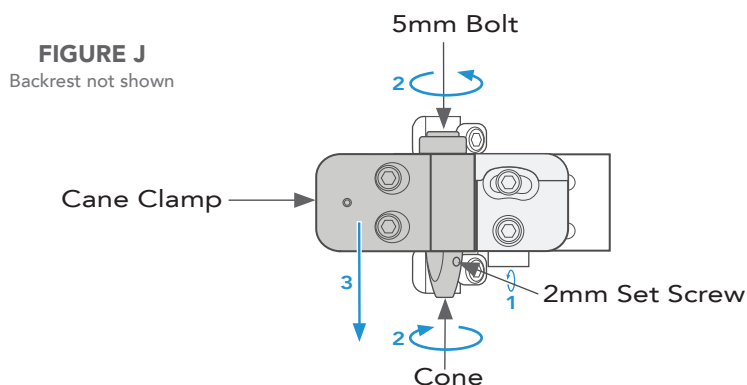

3.2 Now, move the Cane Clamps to the opposite sides of the chair and attach them to the canes at equal height on the canes in the orientation shown (Figure K). Fit the clamps around the canes and lightly tighten the bolts but do not secure them.

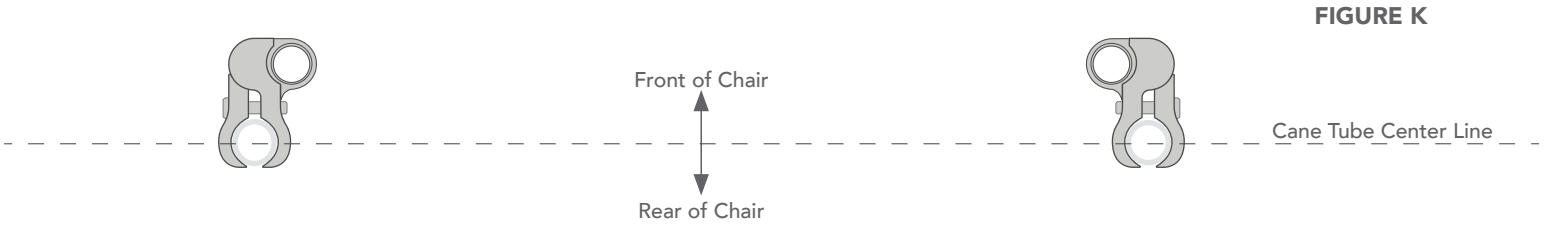

FIGURE K

The Triangle Bracket and Cane Clamp angle allows for width adjustments to be made if using a chair that is different from the ordered backrest width. To make adjustments to the bracket position, loosen (do not remove) the bolts above and below the Triangle Bracket using a 5mm hex key. Slide the bracket into place and tighten the bolts to secure.

With the bolts in the Cam Latch Brackets somewhat loose ($\frac{1}{4}$ turn), slide the backrest onto the cane clamps (Figure L) to ensure the proper position. Secure the cane clamps by alternating between bolts multiple times while tightening to ensure even pressure and a square fit. Finish by tightening the Set Screws on the clamps.

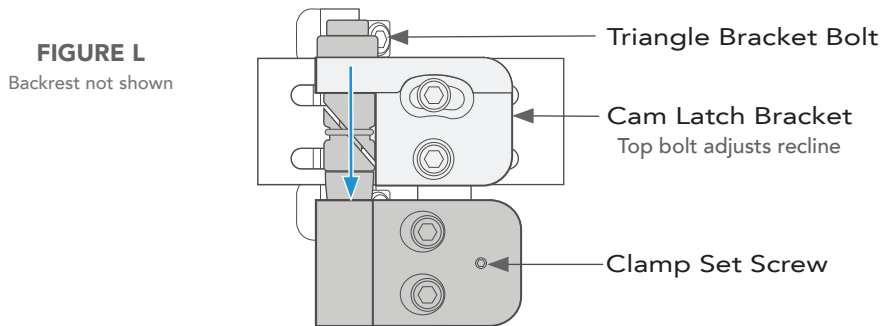

FIGURE L

Backrest not shown

3.3 Now, determine the hardware position based on the desired seat depth and recline. Sliding the Cam Latch Bracket forward will achieve up to 0.8" (2.1 cm) of depth in front of the cane tube and backwards will reach up to 2.8" (7.2 cm) of depth in front of the cane tube (Figure M).

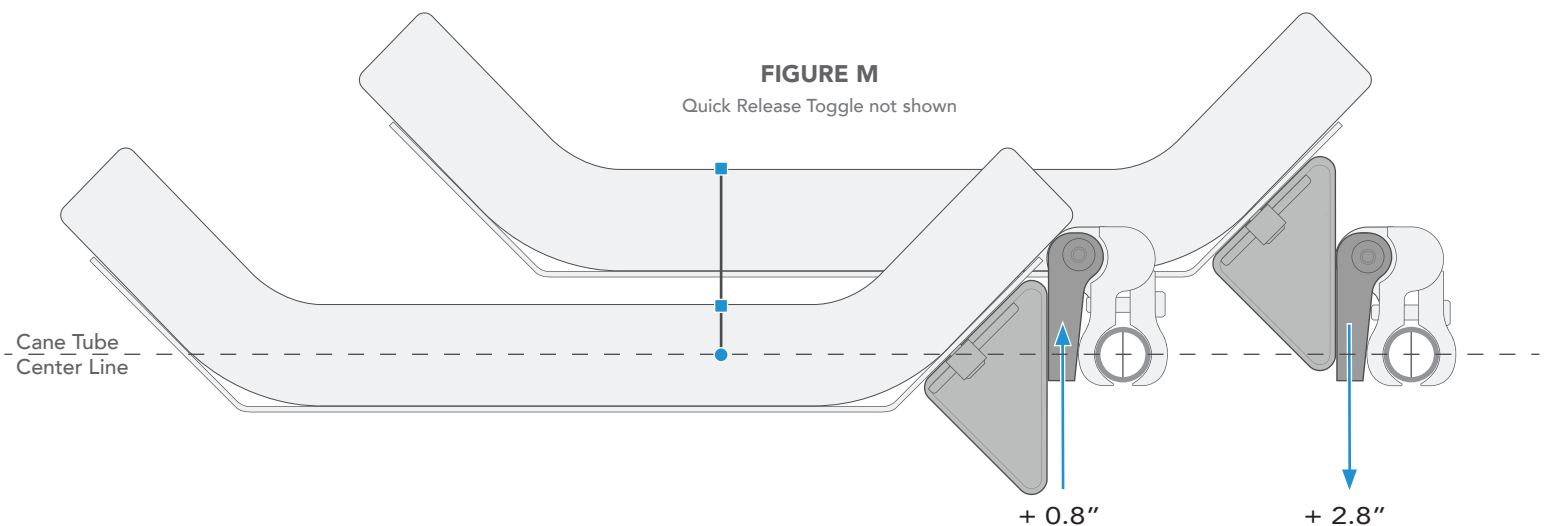

FIGURE M

Quick Release Toggle not shown

3.4

The top bolt located in the Cam Latch Bracket controls the backrest recline. Posterior tilt may cause some loss in seat depth so adjustments may have to be made to achieve proper positioning.

Remove the backrest from the chair and tighten the bolts in the Cam Latch Bracket to secure the position.

Tip: Use a pencil to mark the position of the brackets relative to each other if they are too loose to hold their position when removing the backrest for tightening.

Note: If adjustments are needed to the Triangle Bracket position (Figure N) to achieve the greatest range of positioning, always make sure the Triangle Bracket is at a position where the chair canes are relaxed and the bracket is level to the backrest.

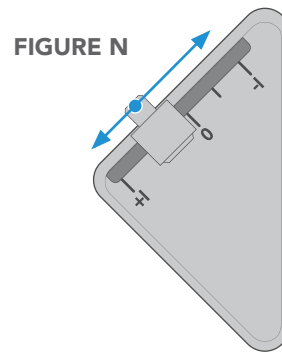

3.5

Replace the backrest on the Cane Clamps and engage the Cam Latching System.

Quick Release Compass® hardware; move toggle to the down position.

Fixed Compass® hardware; tighten the Cam Latch using a 5mm hex key and 11mm open-end wrench. Tighten the 2mm set screws to finish.

IMPORTANT: When installation and adjustments are complete, all bolts* should be tightened to a minimum of 85 in-lbs.

*This does not include set screws.

SKIP TO SECTION 5 FOR 4-POINT HARDWARE INSTRUCTIONS IF NEEDED

SECTION 4

4.0

You will need to use the following hardware configuration (Figure P) to achieve your desired back position. This flips the Cane Clamps and Cam Latch Bracket around to the opposite side of the chair.

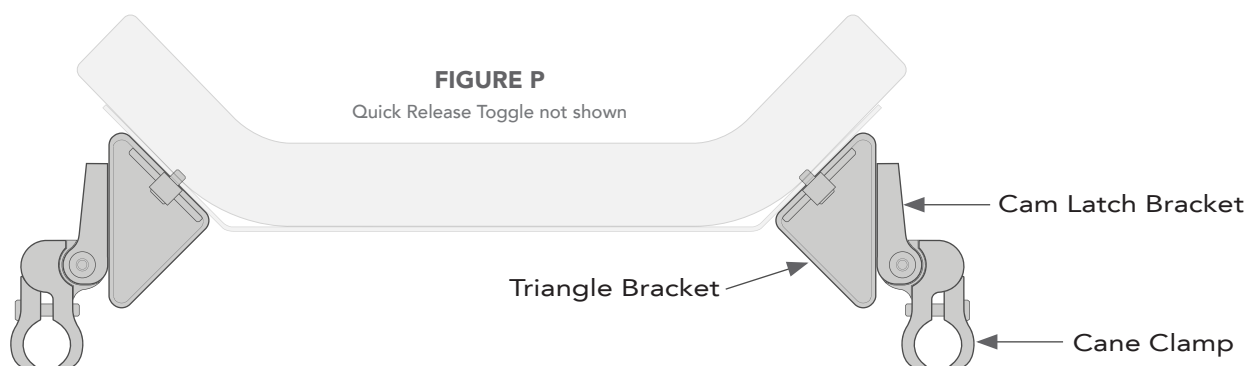

4.1

To switch the Cane Clamp and Cam Latch Bracket around, unscrew the bolts from the Cam Latch Bracket and the Triangle Double Nut located on the underside of the Triangle Bracket. (Figure R)

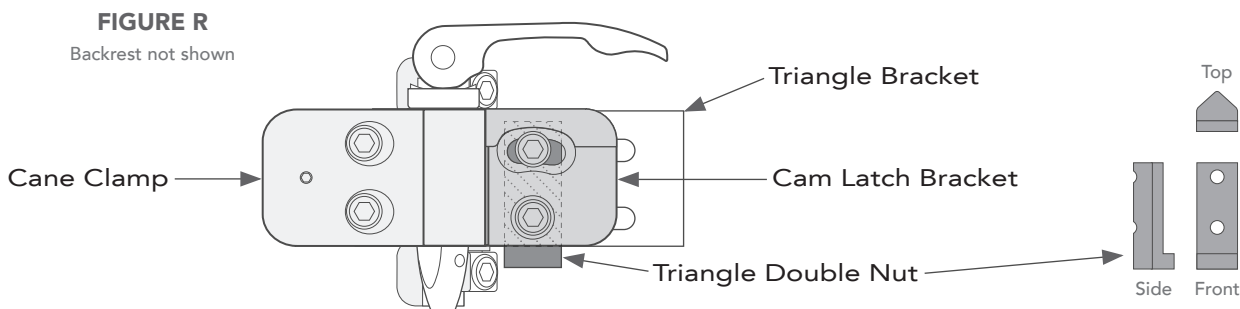

Move the Cane Clamp and Cam Latch Bracket assembly to the opposite side of the backrest and lightly screw the Cam Latch Bracket Bolts back in to the Triangle Bracket and Double Nut assembly (Figure S). Make sure the Triangle Double Nut fits below the bottom edge of the Triangle Bracket.

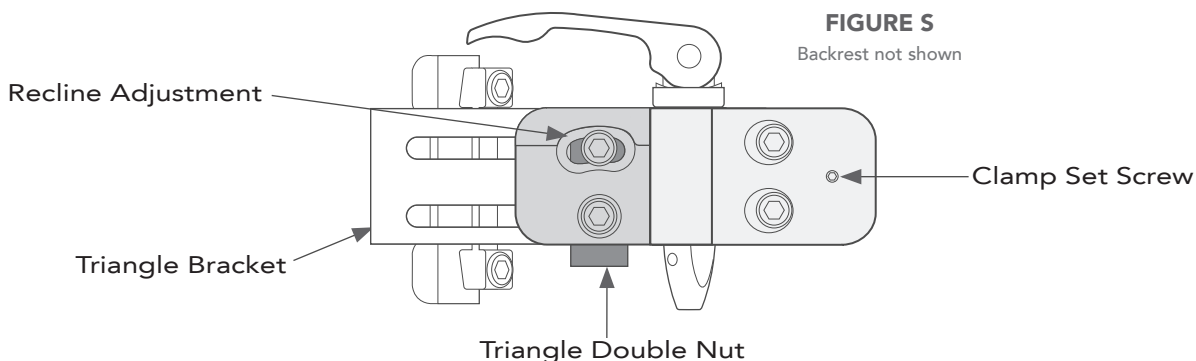

4.2

Next, loosen the 2 bolts on the Cane Clamp. Fit the clamp around the cane at equal height and tighten the bolts to secure. Alternate between bolts multiple times while tightening to ensure even pressure and a square fit. Complete this step for each side of the backrest. Finish by tightening the Set Screw on each clamp.

4.3

With the Cam Latch Bracket loose, determine the hardware position based on the desired seat depth and recline. Sliding the Cam Latch Bracket forward will achieve up to 2.9" (7.2 cm) of depth in front of the cane tube and backwards will reach up to 4.9" (12.3 cm) of depth in front of the cane tube (Figure T).

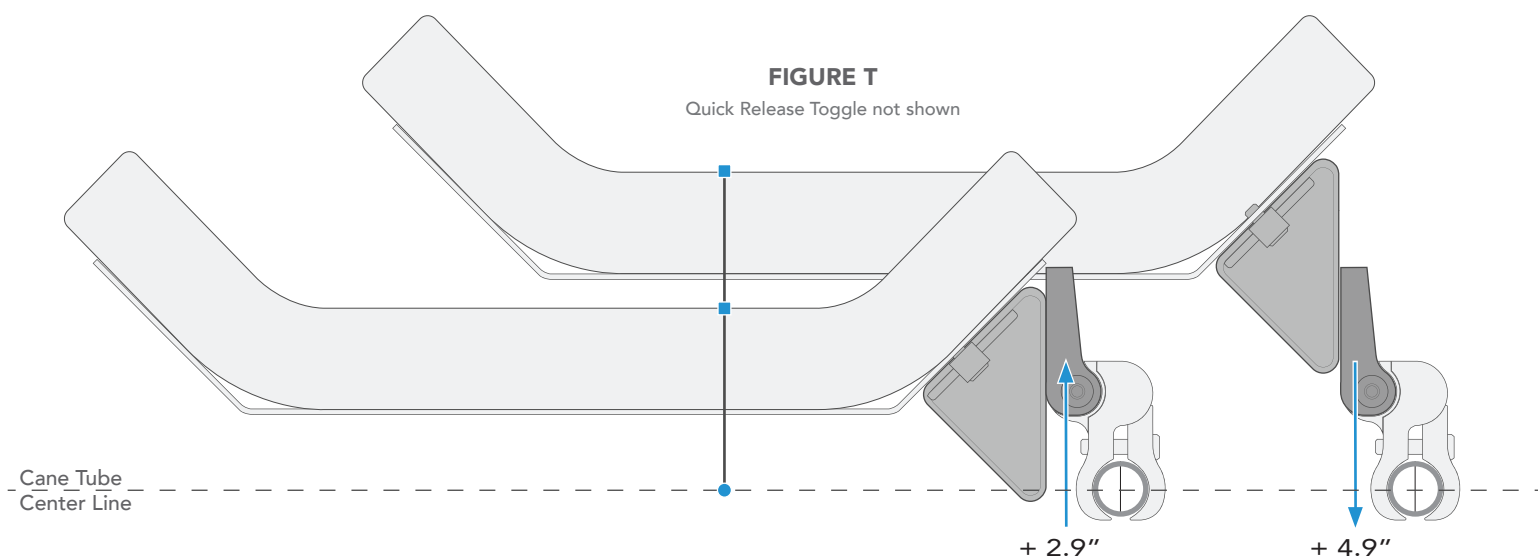

4.4 The top bolt located in the Cam Latch Bracket controls the backrest recline. Fasten the bottom bolt first but do not tighten completely before setting the recline. Posterior tilt may cause some loss in seat depth so the bottom bolt may have to be loosened and readjusted before final tightening can occur.

Once the seat depth is adjusted accordingly, tighten the Cam Latch Bracket bolts on both sides of the chair. Alternate between bolts multiple times while tightening to ensure even pressure.

Note: If adjustments are needed to the Triangle Bracket position (Figure U) to achieve the greatest range of positioning, always make sure the Triangle Bracket is at a position where the chair canes are relaxed and the bracket is level to the backrest.

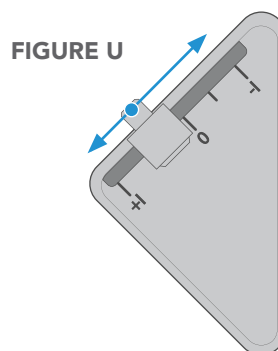

IMPORTANT: When installation and adjustments are complete, all bolts* should be tightened to a minimum of 85 in-lbs.
*This does not include set screws.

SECTION 5: 4-POINT HARDWARE

5.0 Due to differences between wheelchair manufacturers, backrests and patients needs, achieving all possible positions with 4-Point hardware may require flipping the 45° angled bracket.

5.1 Start with all bolts loose in the assembly. This allows for adjusting to the backrest position with the 2-Point Compass hardware already attached and in place.

Completely unscrew the outside 1/8" Hex Bolt on the Cane Clamp (Figure W). Wrap the band around the chair cane with the L Bracket oriented to the front of the cane. Replace the washer and bolt. Tighten the band around the cane using the 1/8" Bolt on the front of the L Bracket. Repeat for the opposite side of the wheelchair with the Cane Clamps at equal height on the canes.

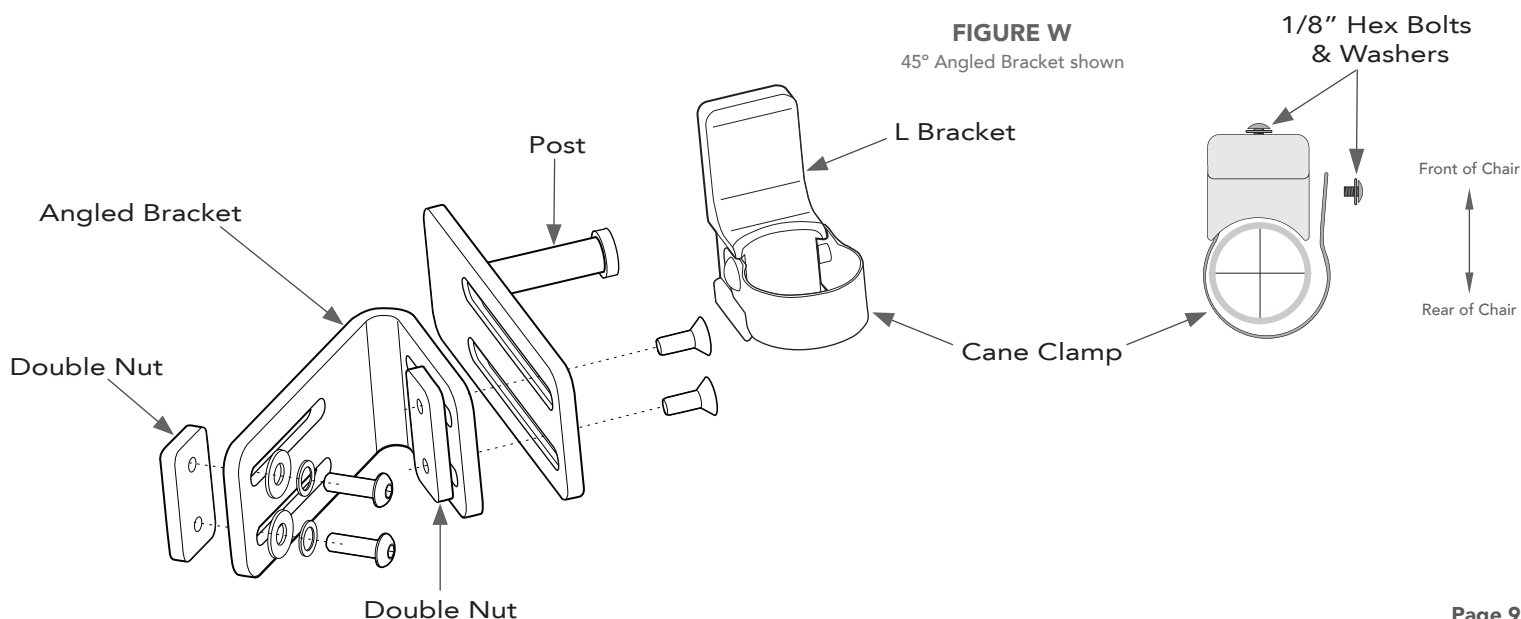

5.2 Shift the Angled Bracket and Post brackets around until the Post can reach and rest on the L Bracket attached to the wheelchair canes (Figure X). Once both sides of the backrest are positioned, tighten all bolts to secure.

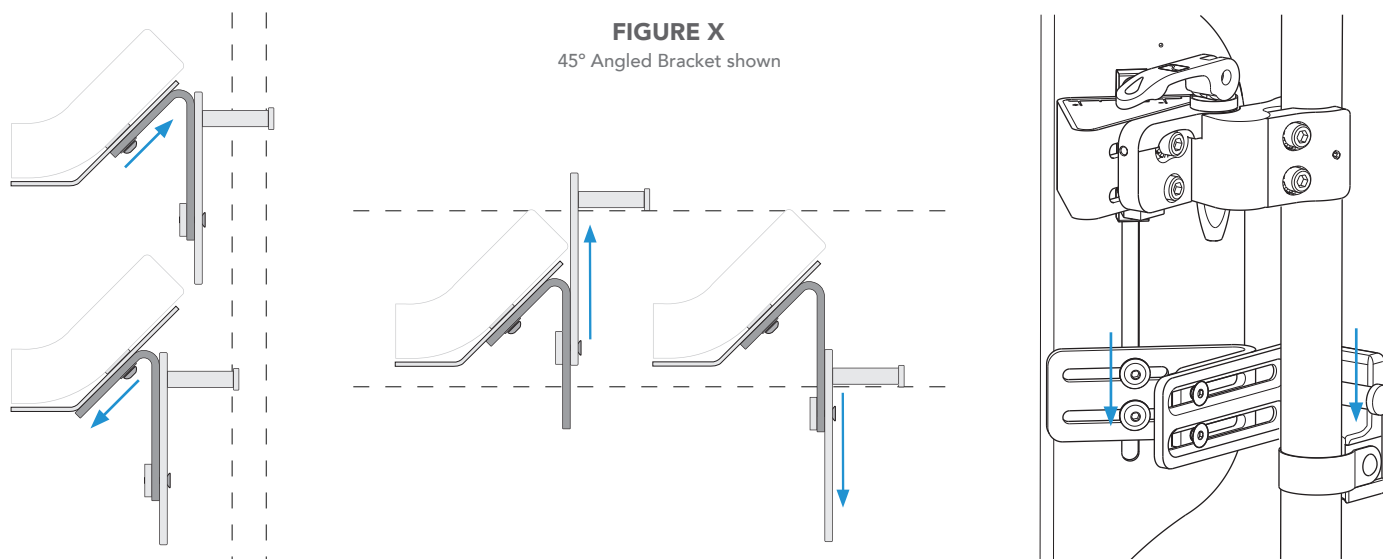

If the 4-point hardware can not reach, use the following instructions on how to flip the 45° Angled Bracket.

5.3 Unscrew the 2 Flat Head Screws (A) and the 2 Button Head Screws (B) in the hardware assembly on each side of the back. This releases Angled Bracket (C). Figure Y

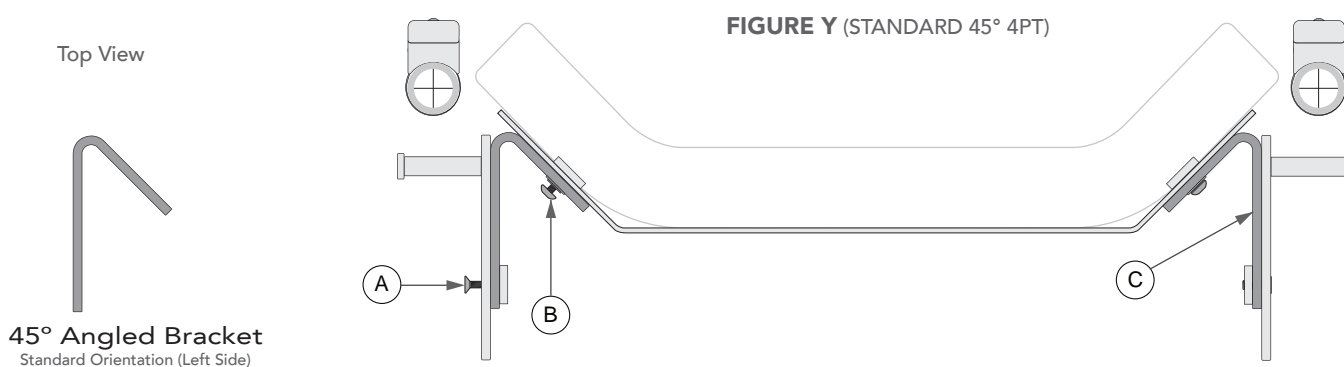

Flip the Angled Bracket around so that the long side rests on the surface of the back shell. Figure Z

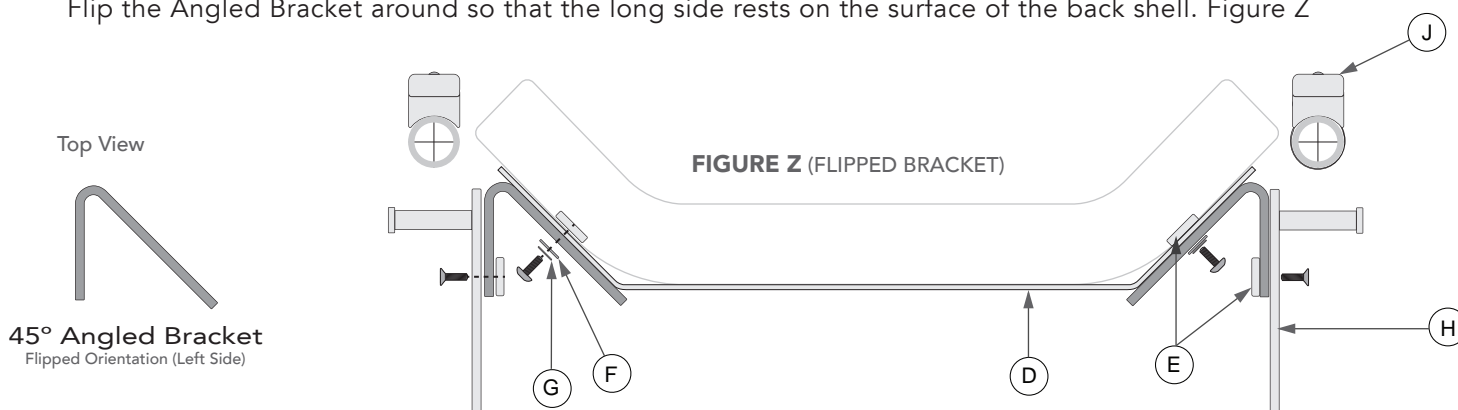

5.4 Reattach the Angled Bracket to the shell, but do not tighten completely. Assembly order (inside to outside of shell) Double Nut (E) - Back Shell (D) - Flat Washer (F) - Split Lock Washer (G) - Button Head Screw (B).

Use the Flat Head screws (A) to attach the Post Bracket (H) to the Angled Bracket, but do not tighten completely. Assembly order (inside to outside) Double Nut (E) - Angled Bracket (C) - Post Bracket (H).

5.5 Shift the Angled Bracket and Post brackets around until the Post can reach and rest on the L Bracket attached to the wheelchair canes. Once both sides of the backrest are positioned, tighten all bolts to secure.