

Invacare® **9000 Series** Wheelchair

9000 SL

9000 XT

9000 XDT

9000XT Recliner

## User Manual

EN

*This manual MUST be given to the user of the product.*

*BEFORE using this product, read this manual and save for future reference.*



***Yes, you can.®***

© 2016 Invacare Corporation. All rights reserved. Republication, duplication or modification in whole or in part is prohibited without prior written permission from Invacare. Trademarks are identified by ™ and ®. All trademarks are owned by or licensed to Invacare Corporation or its subsidiaries unless otherwise noted.

3-in-1 oil is a registered trademark of American Home Products Corporation.

Teflon is a registered trademark of E.I. Du Pont De Nemours and Company.

<b>1 GENERAL</b>	<b>6</b>
Symbols .....	6
Limited Warranty .....	7
<b>2 OVERVIEW</b>	<b>8</b>
Label Locations .....	8
Specifications.....	10
<b>3 SAFETY</b>	<b>15</b>
General Guidelines .....	15
Intended Use.....	16
Wear and Tear Items.....	17
Repair and Service Information .....	17
Operating Information .....	18
Safety/Handling of Wheelchairs.....	25
<b>4 SAFETY INSPECTION</b>	<b>32</b>
Safety Inspection Checklist.....	32

## CONTENTS

<b>5</b>	<b>OPERATION</b>	<b>36</b>
	Unfolding and Folding Wheelchair .....	36
	Installing/Removing Front Riggings .....	38
	Raising/Lowering Elevating Legrest Assembly .....	39
	Installing Impact Guards/Calf Strap .....	40
	Using Swing-Back Arms .....	41
	Removing/Installing the Armrests .....	42
	Removing/Installing Rear Wheels - Quick-Release Axels Only .....	43
	Installing Anti-tippers .....	45
	Using Patient Operated Wheel Locks .....	47
	Installing the Optional Wheel Lock Extension Handle .....	48
<b>6</b>	<b>RECLINER OPERATION</b>	<b>49</b>
	Operating Recliner .....	49
	Storing/Replacing Spreader Bar .....	51
	Adjusting Headrest/Back Upholstery Tension .....	52
	Replacing Headrest Pillow .....	52
	Using/Adjusting Wheel Locks .....	53
	Installing Anti-Tippers .....	54
<b>7</b>	<b>ADJUSTMENT</b>	<b>55</b>
	Adjusting Armrest Height .....	55
	Adjusting Footplate Height .....	56
	Adjusting Quick-Release Axle .....	58
	Adjusting Anti-tippers .....	59
	Adjusting Patient-Operated Wheel Locks .....	61
	Adjusting Attendant Operated Wheel Locks .....	63

**8 TROUBLESHOOTING/MAINTENANCE 64**

---

Troubleshooting .....64  
Maintenance ..... 65  
Cleaning Instructions..... 67

**9 SERVICE 69**

---

Replacing Heel Loop ..... 70  
Replacing Desk/Full Length Armrest Pad (Fixed Height Arms Only).....72  
Replacing Clothing Guards (Fixed Height Arms Only) ..... 72  
Converting Between Space Saver and Conventional Arms ..... 72  
Replacing Seat Upholstery ..... 74  
Replacing Back Upholstery ..... 75  
Adjusting Back Height, Back Angle or Seat Depth..... 77  
Adjusting Seat Width ..... 77  
Removing/Installing Rear Wheels..... 77  
Replacing Rear Wheel Handrim ..... 79  
Installing/Replacing Six or Eight-Inch Front Casters and Forks..... 80  
Adjusting Front Caster Mounting..... 81  
Installing Wheel Lock Shoe Extensions ..... 82

**10 OPTIONS 83**

---

Installing/Cleaning Telescoping I.V. Rod/O2 Holders - Non-Recliner Wheelchairs ..... 84  
Installing Telescoping I.V. Rod - 9000 XT Recliner..... 86  
Installing Crutch and Cane Carrier - Non-Recliner Wheelchairs..... 88  
Installing Amputee Bracket - Non-Recliner Wheelchairs ..... 89

### I General

---

#### I.1 Symbols

##### Warnings

Signal words are used in this manual and apply to hazards or unsafe practices which could result in personal injury or property damage. See the information below for definitions of the signal words.



#### **DANGER**

Danger indicates an imminently hazardous situation which, if not avoided, will result in death or serious injury.



#### **WARNING**

Warning indicates a potentially hazardous situation which, if not avoided, could result in death or serious injury.



#### **CAUTION**

Caution indicates a potentially hazardous situation which, if not avoided, may result in property damage or minor injury or both.



#### **IMPORTANT**

Indicates a hazardous situation that could result in damage to property if it is not avoided.



Gives useful tips, recommendations and information for efficient, trouble-free use.

## 1.2 Limited Warranty

### **PLEASE NOTE: THE WARRANTY BELOW HAS BEEN DRAFTED TO COMPLY WITH FEDERAL LAW APPLICABLE TO PRODUCTS MANUFACTURED AFTER JULY 4, 1975.**

This warranty is extended only to the original purchaser who purchases this product when new and unused from Invacare or a dealer. This warranty is not extended to any other person or entity and is not transferable or assignable to any subsequent purchaser or owner. Coverage under this warranty will end upon any such subsequent sale or other transfer of title to any other person.

This warranty gives you specific legal rights and you may also have other legal rights which vary from state to state.

Invacare warrants the side frames and cross members of this product when purchased new and unused to be free from defects in materials and workmanship for a period of five (5) years from the date of purchase from Invacare or a dealer, with a copy of the seller's invoice required for coverage under this warranty. Invacare warrants the upholstered materials (seat, back and armrests of the arm assembly) and remaining components of this product when purchased new and unused to be free from defects in materials and workmanship for a period of thirteen (13) months from date of purchase from Invacare or a dealer, with a copy of the seller's invoice required for coverage under this warranty. If within such warranty periods any such product shall be proven to be defective, such product shall be repaired or replaced, at Invacare's option. This warranty does not include any labor or shipping charges incurred in replacement part installation or repair of any such product. Invacare's sole obligation and your exclusive remedy under this warranty shall be limited to such repair and/or replacement.

For warranty service, please contact the dealer from whom you purchased your Invacare product. In the event you do not receive satisfactory warranty service, please write directly to Invacare at the address at the bottom of this page. Provide dealer's name, address, the product model number, date of purchase, indicate nature of the defect and, if the product is serialized, indicate the serial number. Do not return products to our factory without our prior consent.

**LIMITATIONS AND EXCLUSIONS: THE FOREGOING WARRANTY SHALL NOT APPLY TO SERIAL NUMBERED PRODUCTS IF THE SERIAL NUMBER HAS BEEN REMOVED OR DEFACED, PRODUCTS SUBJECTED TO NEGLIGENCE, ACCIDENT, IMPROPER OPERATION, MAINTENANCE OR STORAGE, PRODUCTS MODIFIED WITHOUT INVACARE'S EXPRESS WRITTEN CONSENT INCLUDING, BUT NOT LIMITED TO, MODIFICATION THROUGH THE USE OF UNAUTHORIZED PARTS OR ATTACHMENTS; PRODUCTS DAMAGED BY REASON OF REPAIRS MADE TO ANY COMPONENT WITHOUT THE SPECIFIC CONSENT OF INVACARE, OR TO A PRODUCT DAMAGED BY CIRCUMSTANCES BEYOND INVACARE'S CONTROL, AND SUCH EVALUATION WILL BE SOLELY DETERMINED BY INVACARE. THE WARRANTY SHALL NOT APPLY TO NORMAL WEAR AND TEAR OR FAILURE TO ADHERE TO THE PRODUCT INSTRUCTIONS. THE FOREGOING EXPRESS WARRANTY IS EXCLUSIVE AND IN LIEU OF ANY OTHER WARRANTIES WHATSOEVER, WHETHER EXPRESS OR IMPLIED, INCLUDING THE IMPLIED WARRANTIES OF MERCHANTABILITY AND FITNESS FOR A PARTICULAR PURPOSE, AND THE SOLE REMEDY FOR VIOLATIONS OF ANY WARRANTY WHATSOEVER, SHALL BE LIMITED TO REPAIR OR REPLACEMENT OF THE DEFECTIVE PRODUCT PURSUANT TO THE TERMS CONTAINED HEREIN. THE APPLICATION OF ANY IMPLIED WARRANTY WHATSOEVER SHALL NOT EXTEND BEYOND THE DURATION OF THE EXPRESS WARRANTY PROVIDED HEREIN. INVACARE SHALL NOT BE LIABLE FOR ANY CONSEQUENTIAL OR INCIDENTAL DAMAGES WHATSOEVER.**

**SOME STATES DO NOT ALLOW THE EXCLUSION OR LIMITATION OF INCIDENTAL OR CONSEQUENTIAL DAMAGE, OR LIMITATION OF HOW LONG AN IMPLIED WARRANTY LASTS, SO THE ABOVE EXCLUSION AND LIMITATION MAY NOT BE APPLICABLE. THIS WARRANTY SHALL BE EXTENDED TO COMPLY WITH STATE/PROVINCIAL LAWS AND REQUIREMENTS.**

## 2 OVERVIEW

### 2 Overview

#### 2.1 Label Locations

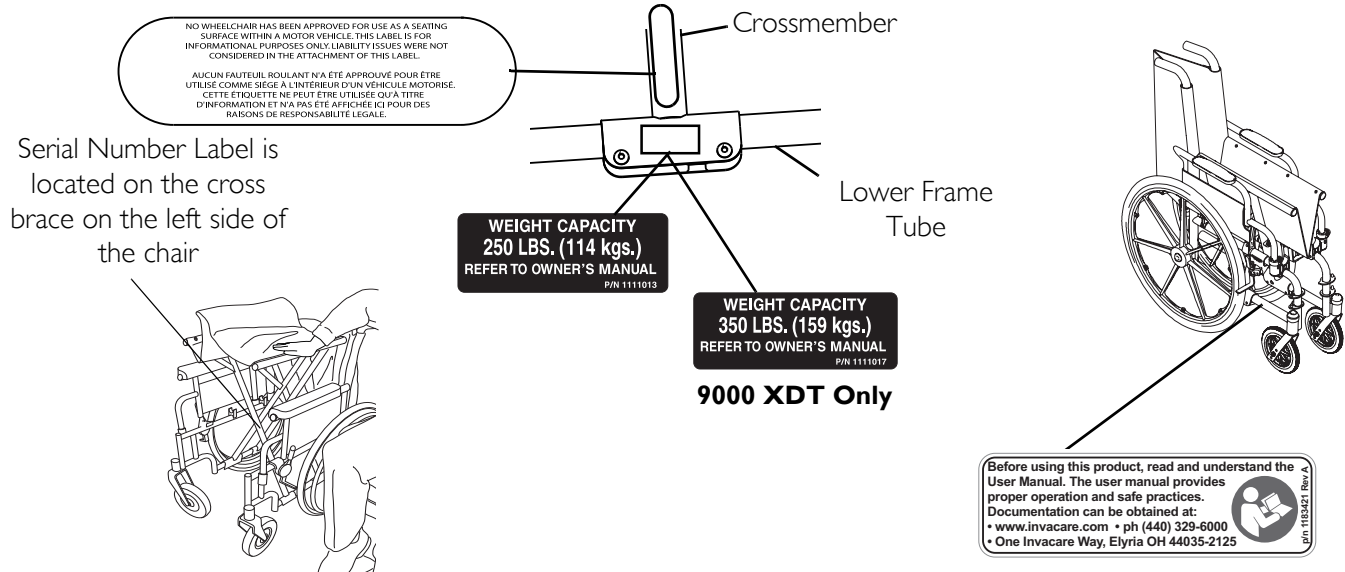



*NOTE: On all adjustable anti-tippers*

**⚠ WARNING**  
Refer to the Owner's Manual for proper anti-tipper setting.

**⚠ AVERTISSEMENT**  
Se référer au manuel de l'utilisateur pour le réglage adéquat de l'antibascul.

No. 1091554

**⚠ WARNING**  
Do not operate without the anti-tip tubes installed.

**⚠ AVERTISSEMENT**  
NE PAS utiliser sans d'abord avoir installé les antibasculs.

No. 1091552

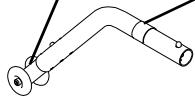

**9000 XT Recliner Models Only**

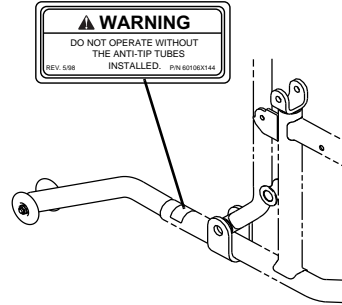

**⚠ WARNING**  
DO NOT OPERATE WITHOUT THE ANTI-TIP TUBES INSTALLED.

REV. 508      INSTALLED:      P/N 60106X144

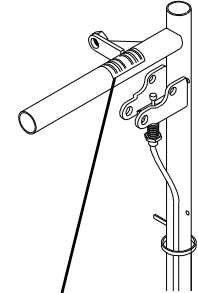

**CAUTION**  
DO NOT recline without occupant. When the chair is not occupied the back will raise abruptly. Keep clear of the chair back when raising or lowering to avoid injury.

1023096

**Models with Quick-Release Axles Only**

**WARNING**  
DETENT BALLS MUST BE SECURELY SEATED IN RECESSED AREAS OF AXLE BUSHINGS. ENSURE THAT PLUNGER PIN IN HEAD END OF AXLE IS FULLY RELEASED. KEEP DETENT BALLS CLEAN.

1001948

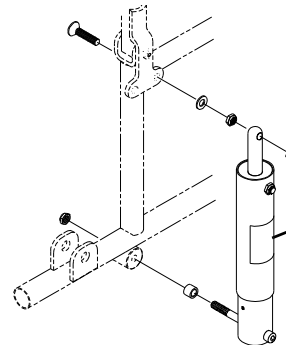
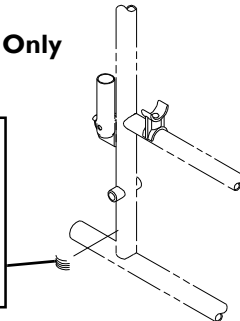

**CAUTION**  
SERVICE OF SPRING LIFT MECHANISM TO BE PERFORMED BY PROPERLY TRAINED AUTHORIZED SERVICE PERSONNEL ONLY.

1022642

## 2 OVERVIEW

### 2.2 Specifications

9000 SL				
<b>OVERALL WIDTH</b>	23 or 25 inches		<b>REAR AXLE</b>	Permanent* and quick-release
<b>OVERALL DEPTH (WITH RIGGINGS)</b>	43½ inches		<b>HANDRIMS</b>	Composite* and aluminum, steel
<b>SEAT WIDTH</b>	16, 18 or 20 inches		<b>WHEEL LOCKS</b>	Toggle lock -push or pull
<b>SEAT DEPTH</b>	16 or 18 inches		<b>CASTER SIZE</b>	6 x 1-inch Urethane, 8 x 1¼-inch* Urethane, 8x1-inch solid rubber, and 8x1¼-inch pneumatic or pneumatic flat-free insert
<b>SEAT-TO-FLOOR</b> TALL/ADULT: ADULT/HEMI: SUPER HEMI:	N/A 15½ to 19½ in 1-inch increments N/A		<b>UPHOLSTERY</b>	Black nylon*, black vinyl
<b>BACK STYLE</b>	Sectional* - 1 inch increments; Adjustable angle - 85° to 110° in 5° increments		<b>WEIGHT (APPROX.)</b>	33½ lbs (18 x 16 seat)
<b>BACK HEIGHT</b>	15 to 19 inches in 1-inch increments		<b>WEIGHT LIMIT</b>	250 lbs (114 kg)
<b>ARM STYLES</b>	Swing Back* Space Saver*, Desk* or full length in Fixed* or Adjustable Height Swing Back Removable, Conventional, Adjustable Height (Adjustable back angle style)		<b>SHIPPING WEIGHT (APPROX.)</b>	43 lbs (16x16 inch seat frame with complete pkg)
<b>FRONT RIGGINGS</b>	Swingaway footrests and elevating legrests		<b>REAR WHEELS</b>	20, 22 and 24*-inch composite; Urethane*, pneumatic or pneumatic-flat free insert

9000 XT				
<b>OVERALL WIDTH</b>	21, 22, 23, 25, 27 or 29 inches		<b>CASTER SIZE</b>	6 x 1-inch Urethane, 8 x 1¼-inch* Urethane, 8x1-inch solid rubber, and 8x1¼-inch pneumatic or pneumatic flat-free insert, 8x1 ¾-inch semi pneumatic
<b>OVERALL DEPTH (WITH RIGGINGS)</b>	43½ inches		<b>HANDRIMS</b>	Composite*, aluminum, steel and plastic coated
<b>SEAT WIDTH</b>	14, 15, 16, 18, 20 or 22 inches		<b>REAR WHEELS</b>	20, 22 and 24*-inch composite; Urethane*, pneumatic or pneumatic-flat free insert
<b>SEAT DEPTH</b>	16, 17, or 18 inches		<b>REAR AXLE</b>	Permanent* and quick-release
<b>SEAT-TO-FLOOR TALL/ADULT:</b>	N/A		<b>UPHOLSTERY</b>	Black nylon*, black sail cloth, heavy vinyl
<b>ADULT/HEMI:</b>	15½ to 19½ in 1-inch increments		<b>SHIPPING WEIGHT (APPROX.)</b>	41½ lbs (16 x 16 inch seat frame with complete package)
<b>SUPER HEMI:</b>	13½ and 14½ inches		<b>WEIGHT (APPROX.)</b>	31 lbs (18 x 16 inch seat)
<b>BACK STYLE</b>	Adjustable* - 1-inch increments Adjustable angle - 85° to 110° in 5° increments		<b>WEIGHT LIMIT</b>	250 lbs (114 kg)
<b>BACK HEIGHT</b>	15 to 19 inches in 1-inch increments		<b>WHEEL LOCKS</b>	Toggle lock -push or pull
<b>ARM STYLES</b>	Swing back removable, space saver* or conventional in desk* or full length and in fixed* or adjustable height			
<b>FRONT RIGGINGS</b>	Swingaway footrests/elevating legrests			

## 2 OVERVIEW

9000 XT RECLINER				
<b>OVERALL WIDTH</b>	23, 25, 27, 28, 29 or 31 inches		<b>REAR WHEELS</b>	20, 22 and 24*-inch composite*; Urethane*, pneumatic or pneumatic-flat free insert
<b>OVERALL DEPTH (WITH RIGGINGS)</b>	46 inches		<b>REAR AXLE</b>	Permanent
<b>SEAT WIDTH</b>	14, 16, 18, 19, 20 or 22 inches		<b>CASTER SIZE</b>	8 x 1¼-inch* Urethane, 8x1-inch solid rubber, and 8x1¼-inch pneumatic or pneumatic flat-free insert, 8x1¼-inch semi pneumatic
<b>SEAT DEPTH</b>	16, 17, or 18 inches		<b>HANDRIMS</b>	Composite*, aluminum, steel and plastic coated
<b>SEAT-TO-FLOOR**</b> TALL/ADULT: ADULT/HEMI: SUPER HEMI:	17½-19½ inches - 1inch increments N/A N/A		<b>UPHOLSTERY</b>	Heavy vinyl, light vinyl, nylon, sail cloth
<b>BACK STYLE</b>	Reclining		<b>WEIGHT LIMIT</b>	250 lbs (114 kg)
<b>BACK HEIGHT</b>	23 or 24 inches		<b>WEIGHT (APPROX.)</b>	50½ lbs
<b>ARM STYLES</b>	Conventional Desk* or full length and in fixed* or adjustable height		<b>SHIPPING WEIGHT (APPROX.)</b>	60½ lbs 18x17-inch seat frame with complete package
<b>FRONT RIGGINGS</b>	Swingaway footrests and elevating legrests		<b>WHEEL LOCKS</b>	Toggle lock - push or pull

9000 XDT				
<b>OVERALL WIDTH</b>	23, 25, 27 or 29 inches		<b>FRONT RIGGINGS</b>	Swingaway and Elevating Footrest
<b>OVERALL DEPTH (WITH RIGGINGS)</b>	45½ inches		<b>WHEEL LOCKS</b>	Toggle lock - push or pull
<b>SEAT WIDTH</b>	16, 18, 20 or 22 inches		<b>CASTER SIZE</b>	8 x 1¼-inch* Urethane, 8x1-inch solid rubber, and 8x1¼-inch pneumatic or pneumatic flat-free insert, 8x1¾-inch semi pneumatic
<b>SEAT DEPTH</b>	16, 17, 18, 19 and 20 inches		<b>REAR WHEELS</b>	24*-inch composite, urethane*, pneumatic or pneumatic-flat free insert
<b>SEAT-TO-FLOOR**</b> TALL/ADULT: ADULT/HEMI: SUPER HEMI:	17½, 19½ and 21½ inches N/A N/A		<b>REAR AXLE</b>	Permanent
<b>BACK STYLE</b>	Adjustable - 1-inch increments		<b>UPHOLSTERY</b>	Black nylon, black sail cloth, heavy vinyl
<b>BACK HEIGHT</b>	15 to 19 inches in 1-inch increments		<b>SHIPPING WEIGHT (APPROX.)</b>	46½ lbs 16x16-inch seat frame with complete package
<b>ARM STYLES</b>	Swing back or removable, space saver* or conventional, desk* or full length and in fixed* or adjustable height		<b>WEIGHT (APPROX.)</b>	36½ lbs
<b>HANDRIMS</b>	Steel*, aluminum and plastic coated		<b>WEIGHT LIMIT</b>	350 lbs (154 kg)

## 2 OVERVIEW



\* These options are standard for this model.

\*\* 9000 SL - The seat-to-floor heights are based on urethane tires. If wheelchair is equipped with pneumatic (properly inflated) or solid rubber tires, add  $\frac{1}{4}$ -inch to the measurements listed above. These heights can vary +/-  $\frac{1}{4}$ -inch due to tire wear and manufacturing tolerances.

\*\* 9000 XT - The seat-to-floor heights are based on urethane tires. If wheelchair is equipped with pneumatic (properly inflated) or solid rubber tires, add  $\frac{1}{4}$ -inch to the measurements listed above. These heights can vary +/-  $\frac{1}{4}$ -inch due to tire wear and manufacturing tolerances.

\*\* 9000 XT Recliner - The seat-to-floor heights are based on pneumatic tires and pneumatic tires with flat free inserts. If wheelchair is equipped with urethane tires, subtract  $\frac{1}{4}$ -inch from the measurements listed above. All heights are measured with properly inflated new tires. These heights can vary +  $\frac{1}{4}$ -inch due to tire wear.

\*\* 9000 XDT - The seat-to-floor heights are based on pneumatic tires and pneumatic tires with flat free inserts. If wheelchair is equipped with urethane tires, subtract  $\frac{1}{4}$ -inch from the measurements listed above. All heights are measured with properly inflated new tires. These heights can vary +  $\frac{1}{4}$ -inch due to tire wear.

---

## 3 Safety

---

The safety section contains important information for the safe operation and use of this product.

### 3.1 General Guidelines



#### **WARNING**

DO NOT use this product or any available optional equipment without first completely reading and understanding these instructions and any additional instructional material such as owner's manuals, service manuals or instruction sheets supplied with this product or optional equipment. If you are unable to understand the warnings, cautions or instructions, contact a healthcare professional, dealer or technical personnel before attempting to use this equipment - otherwise, injury or damage may occur.

A qualified technician **MUST** perform the initial set up of this wheelchair. also, a qualified technician must perform all procedures specifically indicated in the manual.



#### **ACCESSORIES WARNINGS**

##### **Risk of Serious Injury or Damage**

Use of non-Invacare accessories may result in serious injury or damage.

Invacare products are specifically designed and manufactured for use in conjunction with Invacare accessories. Accessories designed by other manufacturers have not been tested by Invacare and are not recommended for use with Invacare products.

DO NOT use non-Invacare accessories.

To obtain Invacare accessories, contact Invacare by phone or at [www.invacare.com](http://www.invacare.com).

### 3 SAFETY



#### **DANGER**

##### **Risk of Death, Serious Injury or Damage**

Use of incorrect or improper replacement (service) parts may cause death, serious injury, or damage.

Replacement parts **MUST** match original Invacare parts.

**ALWAYS** provide the wheelchair serial number to assist in ordering the correct replacement parts.



#### **DANGER**

##### **Risk of Death, Serious Injury, or Damage**

Lighted cigarettes dropped onto an upholstered seating system can cause a fire resulting in death, serious injury, or damage.

Wheelchair occupants are at particular risk of death or serious injury from these fires and resulting fumes because they may not have the ability to move away from the wheelchair.

**DO NOT** smoke while using this wheelchair.



#### **NOTICE**

**THE INFORMATION CONTAINED IN THIS DOCUMENT IS SUBJECT TO CHANGE WITHOUT NOTICE.**

Check all parts for shipping damage and test before using. In case of damage, **DO NOT** use. Contact Invacare/Carrier for further instruction.

### 3.2 Intended Use

The intended use for the manual (mechanical) wheelchair is to provide mobility to persons who may be restricted to a sitting position. The manual wheelchair is intended for ongoing daily use. The models offer a wide range of customization which allows for a better fit for the end user resulting in comfort, lightweight, easier propelling, transferring, and smooth ride. The manual wheelchair is intended for indoor and outdoor use on firm surfaces free of climbing obstacles. All other uses are prohibited.



### 3.3 Wear and Tear Items



Normal wear and tear items and components include but are not limited to: all upholstery items including seat and back upholstery, arm and calf pads, cushions, wheels, tires and casters.

Invacare reserves the right to ask for any item back that has an alleged defect in workmanship. See Warranty policy shipped with the product for specific warranty information.

Refer to User Manual for proper preventative maintenance schedule and use of the product.

This is just a general guideline and does not include items damaged due to abuse and misuse. Useful life is dependant upon many factors.

PRODUCT TYPE	PRODUCT WEAR AND TEAR PART
<b>WHEELCHAIRS:</b>	Wheels • Brake Assembly/Wheel Locks • Hand grips
<b>UPHOLSTERY AND SEATING:</b>	Arm Pads • Seat Cushion Foam • Seat Cushion Covers • Back Cushion Foam • Back Cushion Covers • Headrest Foam • Headrest Covers • Footplate Covers • Calf Pad (if applicable) Foam and Cover

### 3.4 Repair and Service Information



#### **WARNING**

Unless otherwise noted, all service and adjustment should be performed while the wheelchair is unoccupied. After ANY adjustments, repair or service and BEFORE use, make sure all attaching hardware is tightened securely - otherwise injury or damage may result.

## 3 SAFETY

### 3.5 Operating Information

#### General Warnings



#### **WARNING**

To determine and establish your particular safety limits, practice bending, reaching and transferring activities in several combinations in the presence of a qualified healthcare professional before attempting active use of the wheelchair.

Avoid storing or using the wheelchair near open flame or combustible products. Serious injury or damage to property may result.

DO NOT stand on the frame of the wheelchair.

DO NOT use the footplate as a platform. When getting in or out of the wheelchair, make sure that the footplates are in the upward position.

ALWAYS use the handrims for self-propulsion. Inasmuch as the HANDRIMS are an option on this wheelchair (you may order with or without the handrims), Invacare strongly recommends ordering the handrims as an additional safeguard for the wheelchair user.

Invacare recommends that a non-folding device be installed to keep the wheelchair from being folded when left unoccupied in a public place.

DO NOT operate on roads, streets or highways.

DO NOT allow children to play on or operate the wheelchair.

DO NOT operate on soft surfaces such as sand, grass, or gravel.

## Anti-tippers



### WARNING

Anti-tippers are specific to the different seat-to-floor angles and/or seat-to-floor heights. Refer to the charts in Installing/Adjusting Anti-tippers on page 64 for correct usage and adjustment. If these requirements cannot be achieved, **DO NOT** use the wheelchair. Contact a qualified technician. If changing the seat-to-floor height with or without a change to seat-to-floor angle, the correct anti-tippers **MUST** be used to maintain a 1½ to 2-inch ground clearance.

Seat-to-floor angle of 0° or 3°: If so equipped, anti-tippers **MUST** be attached at all times. Inasmuch as the anti-tippers are an option for 0° or 3° on this wheelchair (you may order with or without the anti-tippers), Invacare strongly recommends ordering the anti-tippers as a safeguard for the wheelchair user.

Seat-to-floor angle of 6°: If changing the seat-to-floor angle to 6°, anti-tippers **MUST** be installed.

Anti-tippers **MUST** be fully engaged and release buttons fully protruding out of adjustment holes.

Ensure both anti-tippers are adjusted to the same mounting hole.

Invacare strongly recommends that anti-tippers be used at all times.

The manual wheelchair is intended for indoor and outdoor use on firm surfaces. When outdoors on wet, soft ground or on gravel surfaces, anti-tippers may not provide the same level of protection against tip over. **DO NOT** operate on soft surfaces such as sand, grass or gravel.

## Hand Grips



### WARNING

**ALWAYS** check hand grips for looseness before using the wheelchair. If loose and/or worn, replace **IMMEDIATELY**.

When cleaning rear cane or hand grip areas use only a clean towel lightly dampened with cool water. Verify that grips are dry prior to use. Use of soap or ammonia based cleaning solutions will result in the hand grips sliding off the cane assembly. Failure to observe this warning may result in injury to the user or bystanders.

If the wheelchair is exposed to extreme temperature (above 100°F or below 32°F), high humidity and/or becomes wet, prior to use, ensure that the handgrips **DO NOT** twist on the handle. Otherwise, damage or injury may occur.

## 3 SAFETY

### Seat Positioning Straps



#### **WARNING**

ALWAYS wear your seat positioning strap. Inasmuch as the seat positioning strap is an option on this wheelchair (you may order with or without the seat positioning strap), Invacare strongly recommends ordering the seat positioning strap as an additional safeguard for the wheelchair user. The seat positioning strap is a positioning strap only. It is not designed for use as a safety device withstanding high stress loads such as auto or aircraft safety belts. If signs of wear appear, strap **MUST** be replaced **IMMEDIATELY**.

With regards to seat/chest positioning straps - it is the obligation of the DME dealer, therapists and other healthcare professionals to determine if a seat/chest positioning strap is required to ensure the safe operation of this equipment by the user. Serious injury can occur in the event of a fall from a wheelchair.

### Wheel Locks



#### **WARNING**

**DO NOT** attempt to stop a moving wheelchair with wheel locks. Wheel locks are not brakes.

If the wheelchair is equipped with push to lock wheel locks, elevating legrests, and wheel lock extension handles, the wheel lock extension handles **MUST** be removed before swinging the elevating legrests to the side, otherwise injury or damage may result. Interference between the top of the elevating legrest and the wheel lock extension handle causes the wheel lock to disengage.

Engaging the wheel locks may not prevent the wheelchair from moving on all floor surfaces including those that may be wet or slick. **ALWAYS** exercise caution when transferring into or out of the wheelchair.

### Wheelchair Tie Down Restraints



#### **WARNING**

Wheelchair users should NOT be transported in vehicles of any kind while in wheelchairs. As of this date, the Department of Transportation has not approved any tie-down systems for transportation of a user while in a wheelchair, in a moving vehicle of any type.

It is Invacare's position that users of wheelchairs should be transferred into appropriate seating in vehicles for transportation and use be made of the restraints made available by the auto industry. Invacare cannot and does not recommend any wheelchair transportation systems.

### Tire Pressure



#### **WARNING**

DO NOT use your wheelchair unless it has the proper tire pressure (p.s.i.). DO NOT overinflate the tires. Failure to follow these suggestions may cause the tire to explode and cause bodily harm. The recommended tire pressure is listed on the side wall of the tire.

### Lifting



#### **WARNING**

DO NOT attempt to lift the wheelchair by any removable (detachable) parts. Lifting by means of any removable (detachable) parts of the wheelchair may result in injury to the user or damage to the wheelchair.

9000 XT RECLINER ONLY - DO NOT use the spreader bar to lift the wheelchair. Refer to Storing/Replacing Spreader Bar on page 77.

### 3 SAFETY

#### Weight Limitation



#### **WARNING**

The 9000 SL, 9000 XT, and 9000XT Recliner wheelchairs have a weight limitation of 250 lbs (114 kg). The 9000XDT wheelchair has a weight limitation of 350 lbs (159 kg).

#### Weight Training



#### **WARNING**

Invacare does not recommend the use of its wheelchairs as a weight training apparatus. Invacare wheelchairs have not been designed or tested as a seat for any kind of weight training. If occupant uses said wheelchair as a weight training apparatus, Invacare shall not be liable for bodily injury or damage to the wheelchair and the warranty is void.

#### Storage



#### **WARNING**

##### **Risk of Serious Injury or Damage**

Storing or using the wheelchair near open flame or combustible products can result in serious injury or damage.

Avoid storing or using the wheelchair near open flame or combustible products.

Storing the wheelchair in a damp area or when wet may cause rust or corrosion of wheelchair parts resulting in injury or damage.

DO NOT use the wheelchair in a shower, pool or other body of water.

DO NOT store the wheelchair in a damp or humid area.

Avoid extreme weather such as rain or snow when possible.

Avoid excessive moisture or humidity.

If exposed to water, dry the wheelchair as soon as possible.

**Stability (All Models)****WARNING**

The seat depth, back height/angle, seat angle, size/position of the front casters, size/position of the rear wheels, anti-tipper model, as well as the user condition directly relate to the stability of the wheelchair. Any change to one or any combination of the ten may cause the wheelchair to decrease in stability. These adjustments must be performed by a qualified technician

The various seat-to-floor heights require specific settings depending on rear wheel size, rear wheel position, front caster size/position and desired seat-to-floor angle. These adjustments **MUST** be performed by a qualified technician.

 When changes to the left hand column occur, follow across the chart and refer to the X procedure to maintain the proper stability, safety and handling of the wheelchair.	BACK HEIGHT	SEAT DEPTH	BACK ANGLE	SEATING SYSTEM	TILT ANGLE	CASTER SIZE	CASTER POSITION	WHEEL SIZE	WHEEL POSITION	USER CONDITION	WHEEL LOCKS	ANTI-TIPPERS
BACK HEIGHT	•	X	X	X	X	X	X	X	X	N/A	N/A	N/A
SEAT DEPTH	X	•	X	X	N/A	X	X	X	X	N/A	N/A	N/A
BACK ANGLE	X	X	•	X	X	X	X	X	X	N/A	N/A	N/A
SEATING SYSTEM	X	X	X	•	X	X	X	X	X	X	N/A	N/A
TILT ANGLE	N/A	N/A	X	N/A	•	N/A	N/A	N/A	N/A	N/A	N/A	N/A
CASTER SIZE	X	N/A	X	N/A	N/A	•	X	X	X	N/A	X	X
CASTER POSITION	X	N/A	X	N/A	N/A	X	•	X	X	N/A	X	X
WHEEL SIZE	X	N/A	X	N/A	N/A	X	X	•	X	N/A	X	X
WHEEL POSITION	X	N/A	X	N/A	N/A	X	X	X	•	N/A	X	X
USER CONDITION	X	X	X	X	X	X	X	X	X	•	N/A	N/A
SEAT HEIGHT	X	N/A	X	X	X	X	X	X	X	N/A	X	X

## 3 SAFETY

### Stability (Recliner Models Only)



#### **WARNING**

ALWAYS make sure that the wheelchair is stable before using the recliner option.

Ensure the spreader bar is attached and secured before using the 9000XT Recliner.

ALWAYS return the back to the upright position before lifting the wheelchair.

LIFT KIT MODELS ONLY - Both spring lift mechanisms MUST be operational before using the recliner. DO NOT operate the recliner option if only one of the spring lift mechanisms is operational.

LIFT KIT MODELS ONLY - DO NOT attempt to recline or incline the wheelchair back without occupant. Back will raise abruptly and cause injury. Keep clear when reclining or inclining chair back to avoid injury.

### Ramps, Slopes, Inclines, and Obstacles



#### **WARNING**

DO NOT traverse, climb or go down ramps or slopes greater than 9°.

DO NOT attempt to move up or down an incline with a water, ice or oil film.

DO NOT attempt to ride over curbs or obstacles. Doing so may cause your wheelchair to tip over and cause bodily harm to you or damage to the wheelchair.

NEVER leave an unoccupied wheelchair on an incline.

DO NOT attempt to stop the wheelchair while on a sloped surface.



## Information for Healthcare Professionals/Assistants



### **WARNING**

When assistance to the wheelchair user is required, remember to use good body mechanics. Keep your back straight and bend your knees whenever tipping the wheelchair or traversing curbs, or other impediments.

Make sure the patient is properly positioned in the wheelchair before reclining or inclining (reverse recline) to maintain maximum stability and safety. Refer to [Safety/Handling of Wheelchairs](#) on page 25.

Make sure occupant's hands and body are clear of all pinch points before reclining back. Pinch points exist between spreader bar and recliner mechanism. Use caution, otherwise injury may occur.

ALWAYS engage both wheel locks while reclining or inclining (reverse recline) the wheelchair.

When returning the occupant of the reclining back wheelchair to the full upright position, more body strength will be required for approximately the last twenty degrees of incline (reverse recline). Make sure to use proper body mechanics (use your legs) or seek assistance if necessary to avoid injury.

DO NOT attempt to recline or incline the wheelchair back without occupant. Back will raise abruptly and cause injury. Keep clear when reclining or inclining chair back to avoid injury.

When learning a new assistance technique, have an experienced assistant help you before attempting it alone.

## Wheelchair User



### **WARNING**

As a manufacturer of wheelchairs, Invacare endeavors to supply a wide variety of wheelchairs to meet many needs of the end user. However, final selection of the type of wheelchair to be used by an individual rests solely with the user and his/her healthcare professional capable of making such a selection.

## 3.6 Safety/Handling of Wheelchairs

Safety and handling of the wheelchair require the close attention of the wheelchair user as well as the assistant. This manual points out the most common procedures and techniques involved in the safe operation and maintenance of the wheelchair. It is important to practice and master these safe techniques until you are comfortable in maneuvering around the frequently encountered architectural barriers.

### 3 SAFETY

Use this information only as a basic guide. The techniques that are discussed on the following pages have been used successfully by many.

Individual wheelchair users often develop skills to deal with daily living activities that may differ from those described in this manual. Invacare recognizes and encourages each individual to try what works best for him/her in overcoming architectural obstacles that they may encounter. However, all warnings and cautions given in this manual **MUST** be heeded. Techniques in this manual are a starting point for the new wheelchair user and assistant with “safety” as the most important consideration for all.

#### Stability and Balance



#### **WARNING**

Be aware that carrying heavy objects on your lap while occupying the wheelchair may adversely affect the stability of the wheelchair, resulting in serious bodily injury to the user, damage to the wheelchair and surrounding property.

This wheelchair has been designed to accommodate one individual. If more than one individual occupies the wheelchair this may adversely affect the stability of the wheelchair, resulting in serious bodily injury to the user and passenger and damage to the wheelchair and surrounding property.

To assure stability and proper operation of your wheelchair, you **MUST** maintain proper balance at all times. Your wheelchair has been designed to remain upright and stable during normal daily activities as long as you **DO NOT** move beyond the center of gravity.

Virtually all activities which involve movement in the wheelchair have an effect on the center of gravity. Invacare recommends using seat/chest positioning straps for additional safety while involved in activities that shift your weight.

**DO NOT** lean forward out of the wheelchair any further than the length of the armrests. Make sure the casters are pointing in the forward position whenever you lean forward. This can be achieved by advancing the wheelchair and then reversing it in a straight line.

Many activities require the wheelchair owner to reach, bend and transfer in and out of the wheelchair. These movements will cause a change to the normal balance, the center of gravity, and the weight distribution of the wheelchair.

To determine and establish your particular safety limits, practice bending, reaching and transferring activities in several combinations in the presence of a qualified healthcare professional before attempting active use of the wheelchair.

Proper positioning is essential for your safety. When reaching, leaning, or bending forward, it is important to use the front casters as a tool to maintain stability and balance.

## Reaching, Leaning and Bending



### WARNING

DO NOT shift your weight or sitting position toward direction you are reaching as the wheelchair may tip over.  
 DO NOT attempt to reach objects if you have pick them up from the floor by reaching down between your knees.  
 DO NOT lean over the top of the back upholstery to reach objects behind you, as this may cause the wheelchair to tip over.

### Forward

Position the front casters so that they are extended as far forward as possible and engage wheel locks.

### Backwards

Position wheelchair as close as possible to the desired object. Point front casters forward to create the longest possible wheelbase. Reach back only as far as your arm will extend without changing your sitting position.

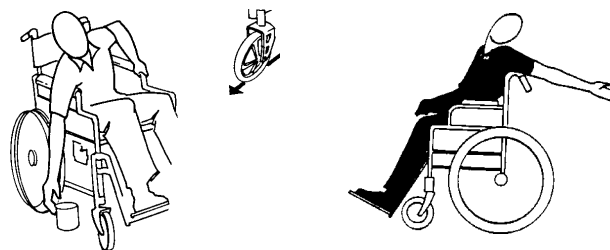

**FIGURE 1** Backwards

## Coping With Everyday Obstacles

Coping with the irritation of everyday obstacles can be alleviated somewhat by learning how to manage your wheelchair. Keep in mind your center of gravity to maintain stability and balance.

### 3 SAFETY

#### Tipping



#### **WARNING**

DO NOT tip the wheelchair without assistance.

When lowering the front casters of the wheelchair, Do not let the wheelchair drop the last few inches to the ground. This could result in injury to the occupant and/or damage to the wheelchair.

When tipping the wheelchair, an assistant should grasp the back of the wheelchair on a non-removable (non-detachable) part. Inform the wheelchair occupant before tipping the wheelchair and remind him/her to lean back. Be sure the occupant's feet and hands are clear of all wheels and/or pinch points.

After mastering the techniques of tipping the wheelchair, use one of the following methods to tackle curbs, short stairs, etc.

#### **Method 1 - Wheelchair With Step Tubes**

Place foot on the step tube and begin to tilt the wheelchair toward you. Apply a continuous downward motion until the balance point is achieved and the front casters clear the curb. At this point, the assistant will feel a difference in the weight distribution.

Roll the wheelchair forward and slowly lower the front of the wheelchair in one continuous movement onto the sidewalk. Push the wheelchair forward until the rear wheels roll up and over the curb.

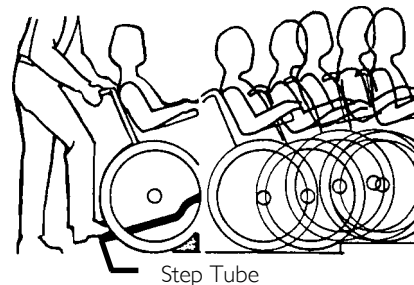

**FIGURE 2** Method 1 - Wheelchair With Step Tubes

#### **Method 2 - Wheelchair Without Step Tubes**

This method requires two assistants. The second assistant should be positioned at the front of the wheelchair lifting upward on a non-removable (non-detachable) part of the wheelchair frame when lifting the wheelchair and stabilizing the wheelchair when the wheelchair is being lowered to the ground.

The first assistant should stand on the sidewalk and turn the wheelchair so that the rear wheels are against the curb. Turn the anti-tippers so the anti-tip wheels are pointing up. The wheelchair should be tilted back to the balance point and, in one continuous upward movement, the rear wheels should be pulled up and over the curb. **DO NOT** return the front casters to the ground until the wheelchair has been pulled backward far enough for the front casters to clear the edge of the curb.

Roll the wheelchair backward and slowly lower the wheelchair in one continuous movement. Turn the anti-tippers so the anti-tip wheels are facing down.

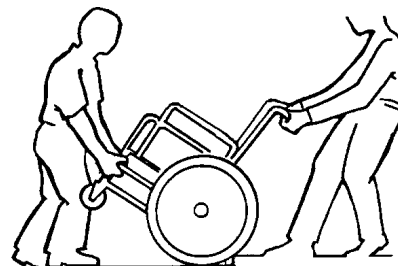

**FIGURE 3** Method 2 - Wheelchair Without Step Tubes

## Stairways



### **WARNING**

Extreme caution is advised when it is necessary to move an occupied or unoccupied wheelchair up or down the stairs. Invacare recommends that, if possible, the user be removed from the wheelchair prior to moving. Invacare recommends using two assistants and making thorough preparations. Make sure to use only secure, non-detachable parts for hand-held supports.

9000 XT recliner only - **ALWAYS** return the back to the upright position before lifting the wheelchair.

Follow this procedure for moving the wheelchair between floors when an elevator is not available:

### **Moving Up Stairs**

1. If necessary, rotate the anti-tippers so the wheels are facing up.
2. One assistant (positioned behind the wheelchair), securely grasps a non-removable (non-detachable) part of the wheelchair for leverage and tilts the wheelchair back to the balance point.
3. After the wheelchair has been tilted back to the balance point, the assistant behind the wheelchair backs the wheelchair up against the first step.

### 3 SAFETY

4. The second assistant (positioned in the front of the wheelchair), with a firm hold on a non-detachable part of the framework, lifts the wheelchair up and on to the next stair above and steadies the wheelchair as the assistant behind the wheelchair places one foot on the next stair above and repeats process.
5. The wheelchair should not be lowered until the last stair has been negotiated and the wheelchair has been rolled away from the stairway.
6. If necessary, rotate the anti-tippers so the wheels are facing down.

#### Moving Down Stairs

1. If necessary, rotate the anti-tippers so the wheels are facing up.
2. One assistant (positioned behind the wheelchair), securely grasps a non-removable (non-detachable) part of the wheelchair for leverage and tilts the wheelchair back to the balance point.
3. After the wheelchair has been tilted back to the balance point, the assistant behind the wheelchair rolls the wheelchair up to the edge of the first step.
4. The second assistant (positioned in the front of the wheelchair), with a firm hold on a non-detachable part of the framework, lowers the wheelchair down and on to the next stair below and steadies the wheelchair as the assistant in the rear places one foot on the next stair below and repeats process.
5. The wheelchair should not be lowered until the last stair has been negotiated and the wheelchair has been rolled away from the stairway.
6. If necessary, rotate the anti-tippers so the wheels are facing down.

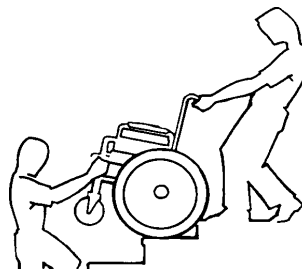

**FIGURE 4** Stairways

## Escalators



### WARNING

DO NOT use an escalator to move a wheelchair between floors. Serious bodily injury may occur.

## Transferring To and From Other Seats



### WARNING

Before attempting to transfer in or out of the wheelchair, every precaution should be taken to reduce the gap distance. Turn both casters parallel to the object you are transferring onto. Also be certain the wheel locks are engaged to help prevent the wheels from moving.



### CAUTION

When transferring, position yourself as far back as possible in the seat. This will help prevent damaged upholstery and the possibility of the wheelchair tipping forward.



This activity may be performed independently provided you have adequate mobility and upper body strength.

Position the wheelchair as close as possible alongside the seat to which you are transferring, with the front casters pointing parallel to it. Remove or flip up the armrest. Engage wheel locks. Swing away or remove front rigging. Shift body weight into seat with transfer.

During independent transfer, little or no seat platform will be beneath you. Use a transfer board if at all possible.

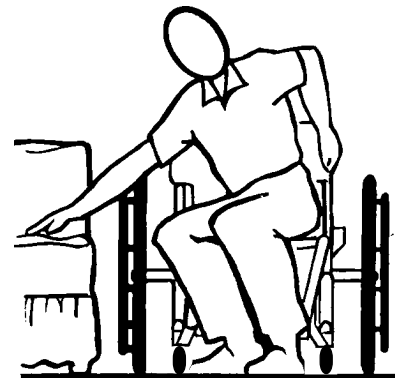

**FIGURE 5** Transferring To and From Other Seats

## 4 SAFETY INSPECTION

---

### 4 Safety Inspection

---



Every six months or as necessary, take your wheelchair to a qualified technician for a thorough inspection and servicing. Regular cleaning will reveal loose or worn parts and enhance the smooth operation of your wheelchair. To operate properly and safely, your wheelchair **MUST** be cared for just like any other vehicle. Routine maintenance will extend the life and efficiency of your wheelchair.

#### 4.1 Safety Inspection Checklist

Initial adjustments should be made to suit your personal body structure and preference. Thereafter follow these maintenance procedures:

##### Inspect/Adjust Initially

- Ensure that the wheelchair rolls straight (no excessive drag or pull to one side).
- Inspect for loose or missing hardware on frame and crossbraces.
- Inspect for bent frame or crossbraces.
- Check that the wheel locks **DO NOT** interfere with tires when rolling.
- Check that the wheel lock pivot points are free of wear and looseness.
- Check that the wheel locks are easy to engage.
- Ensure that the wheel locks prevent the wheelchair from moving when engaged.
- Inspect the seat and back for rips and sagging.
- Inspect the seat and back for loose or broken hardware.
- Inspect the back cane hand grips for wear/looseness/deterioration.
- Inspect seat positioning strap for any signs of wear. Ensure buckle latches. Verify hardware that attaches strap to frame is secure and undamaged. Replace if necessary.
- Inspect tires for flat spots and wear.
- Check pneumatic tires for proper inflation.





### CAUTION

As with any vehicle, check the wheels and tires periodically for cracks and wear. Replace if damaged.

- If equipped, check that quick-release axles lock properly. Lubricate if necessary.
- Check that there is no excessive side movement or binding in the rear wheels when lifted and spun.
- Inspect rear wheels for cracked, bent or broken spokes.
- Ensure all spokes are uniformly tight.
- Inspect handrims for signs of rough edges or peeling.
- Inspect axle assembly for proper tension by spinning caster. Caster should come to a gradual stop.
- Adjust front casters/forks bearing system if wheel wobbles noticeably or binds to a stop.
- Ensure wheel bearings are clean and free of moisture.
- Check headtube locknuts for tightness.
- Inspect casters for cracks and wear.
- Inspect front casters for cracked, bent or broken spokes.



### CAUTION

#### Damage from Bleach

Clean upholstery with mild soap and water or spray disinfectant using a sponge. DO NOT use bleach or wash in a washing machine.

- Clean upholstery and armrests.

#### Inspect/Adjust Weekly

- Ensure that the wheel locks prevent the wheelchair from moving when engaged.
- Inspect tires for flat spots and wear.
- Check pneumatic tires for proper inflation.
- If equipped, check that quick-release axles lock properly. Lubricate if necessary.

## 4 SAFETY INSPECTION

- Inspect rear wheels for cracked, bent or broken spokes.
- Ensure all spokes are uniformly tight.
- Inspect axle assembly for proper tension by spinning caster. Caster should come to a gradual stop.
- Inspect front caster for cracked, bent or broken spokes.

### **Inspect/Adjust Monthly**

- Ensure that the wheelchair rolls straight (no excessive drag or pull to one side).
- Check that the wheel locks DO NOT interfere with tires when rolling.
- Check that the wheel lock pivot points are free of wear and looseness.
- Inspect seat and back for loose or broken hardware.
- Inspect seat positioning strap for any signs of wear. Ensure buckle latches. Verify hardware that attaches strap to frame is secure and undamaged. Replace if necessary.
- Inspect back cane hand grips for wear/looseness/deterioration.
- Adjust front casters/forks bearing system if wheel wobbles noticeably or binds to a stop.
- Ensure wheel bearings are clean and free of moisture.
- Check headtube locknuts for tightness.

### Inspect/Adjust Periodically

- Inspect frame and crossbraces for loose or missing hardware.
- Inspect for bent frame or crossbraces.
- Check that wheel locks are easy to engage.
- Inspect seat and backs for rips and sagging.
- Check that there is no excessive side movement or binding in the rear wheels when lifted and spun.
- Inspect handrims for signs of rough edges or peeling.
- Adjust front casters/forks bearing system if wheel wobbles noticeably or binds to a stop.
- Inspect casters for cracks and wear.
- Ensure that casters are free of debris.
- Ensure wheel bearings are clean and free of moisture.
- Clean upholstery and armrests.
- Check that all labels are present and legible. Replace if necessary.

## 5 OPERATION

### 5 Operation

#### 5.1 Unfolding and Folding Wheelchair



#### **WARNING**

ALWAYS keep hands and fingers clear of moving parts to avoid injury.

DO NOT place hand or fingers on the underside of the seat frame rail when opening or closing the wheelchair.

DO NOT sit or transfer into the wheelchair unless it is fully open and the seat frame rails are fully seated into the side frame H-blocks.

#### **Unfolding**

1. Tilt the wheelchair toward you (raising the opposite wheel and caster off the ground/floor).
2. Place your hand on the top of the seat rail closest to you where the seat upholstery is attached.
3. Point your fingers and thumb to the inside of the wheelchair.
4. Press downward on the top of the seat rail until the wheelchair is fully open and the seat rails are fully seated in the H-blocks.
5. **9000 XT RECLINERS ONLY** - Secure the detached end of the spreader bar to the side frame. Refer to [Storing/Replacing Spreader Bar](#) on page 77.
6. Engage both wheel locks, open the footrest/legrest for clearance and transfer into the wheelchair. Refer to [Transferring To and From Other Seats](#) on page 31.

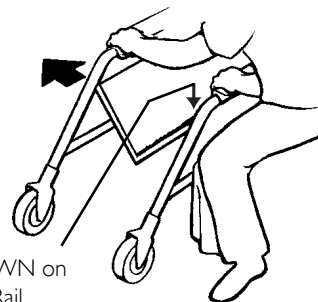

Press DOWN on  
Seat Rail

**FIGURE 1** Unfolding and Folding Wheelchair

### Folding Hammock or Sling Seat Models

1. 9000 XT RECLINERS ONLY - Detach one end of the spreader bar from the side frame. Refer to [Storing/Replacing Spreader Bar](#) on page 77.
2. Swing footrest/legrest in locked position to the front of the wheelchair.
3. Pivot footplates upward to vertical position.
4. With both hands, grasp the middle of the seat upholstery at the front and back edge and lift up.
5. Continue to close the wheelchair by grasping the armrest furthest from you and pulling the armrest towards you.

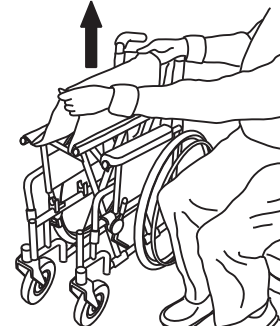

**FIGURE 2** Folding Hammock or Sling Seat Models

### Folding Solid-Seat Models

1. 9000 XT RECLINERS ONLY - Detach one end of the spreader bar from the side frame. Refer to [Storing/Replacing Spreader Bar](#) on page 77.
2. Swing footrest/legrest in locked position to the front of the wheelchair.
3. Pivot footplates upward to vertical position.
4. From behind the wheelchair, grasp the right hand edge of the solid seat.
5. Raise the seat to the hinged side.
6. With both hands, grasp the middle of the front and back edges of the solid folding seat and lift up until the wheelchair begins to close.
7. Continue to close the wheelchair by grasping the armrest furthest from you and pulling the armrest towards you.

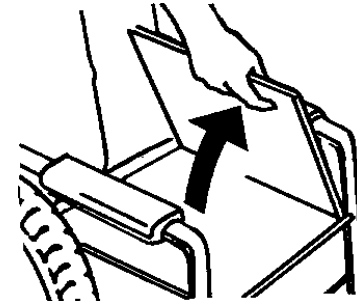

**FIGURE 3** Folding Solid-Seat Models

## 5 OPERATION

### 5.2 Installing/Removing Front Riggings

#### Installing

1. Turn the front rigging assembly to the side (open front rigging is perpendicular to wheelchair).
2. Install the hinge plates of the front rigging assembly onto the hinge pins on the wheelchair frame.

**i** When performing STEP 3, it may be necessary to pull release lever toward front of chair to assist the front rigging to lock in place.

3. Push the front rigging assembly towards the inside of the wheelchair until it locks into place.

**i** The footplate will be on the inside of the wheelchair when locked in place.

4. Repeat this procedure for the other front rigging assembly.
5. To release the front rigging, push the front rigging release lever inward, rotate front rigging outward.

#### Removing

1. Push the front rigging release lever inward.
2. Rotate swingaway front rigging assembly outward.
3. Lift the swingaway front rigging assembly off the hinge pins.

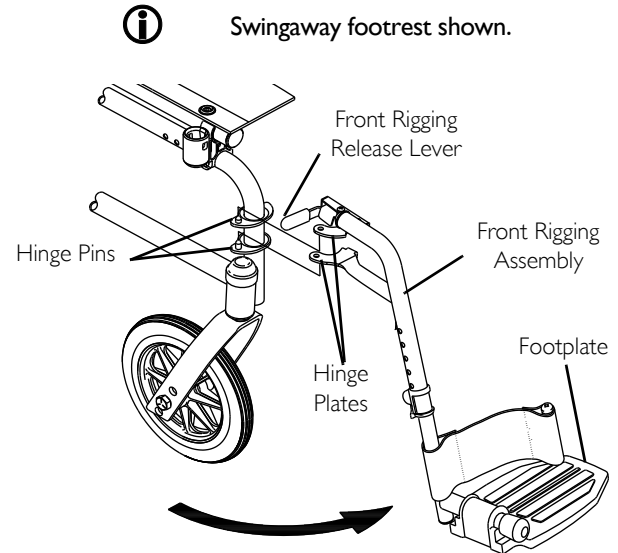

**FIGURE 4** Installing/Removing Front Riggings

### 5.3 Raising/Lowering Elevating Legrest Assembly



#### WARNING

Ensure hands and fingers are clear of elevating legrest mechanism before pushing release lever to lower the elevating legrest. Otherwise injury may occur due to pinch points.

The wheelchair user's leg **MUST** be supported by an assistant before attempting to lower legrest.

1. To raise the elevating legrest, the assistant should hold the support tube and raise the elevating legrest until the desired height is obtained.
2. To lower the elevating legrest, perform the following:
  - A. Support user leg with one hand.
  - B. Push release lever downward with other hand.
  - C. Gently, lower user leg down and rest against the legrest.

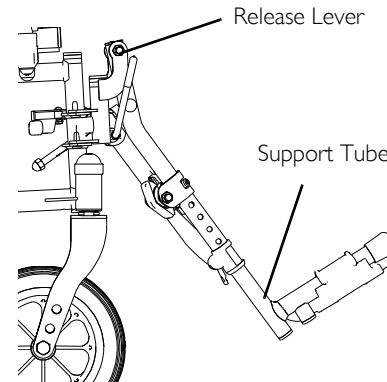

**FIGURE 5** Raising/Lowering Elevating Legrest Assembly

## 5 OPERATION

### 5.4 Installing Impact Guards/Calf Strap.

1. Remove impact guard/calf strap from packaged container if not already secured to the footrest.
2. Secure one impact guard to the each footrest.



Ensure the upper portion of the impact guard is between the two horizontal supports of the footrest.

3. Secure one side of the calf strap around each footrest (with the impact guards attached, if present).

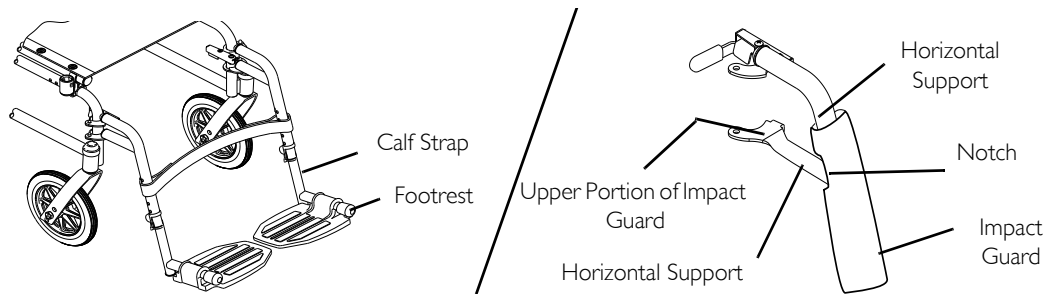

**FIGURE 6** Installing Impact Guards/Calf Strap.



## 5.5 Using Swing-Back Arms



### WARNING

Make sure the armrest release lever is in the locked position before using the wheelchair.



This procedure applies to 9000SL, 9000XT, and 9000XDT wheelchairs only.

1. Unlock the swing-back arms by rotating the armrest release lever toward the outside of the wheelchair.
2. Pull the front of the swing-back arm straight up/out of the arm socket and towards the rear of the wheelchair.
3. To use the swing-back arm, push the swing-back arm towards the front of the wheelchair and then downward into the arm socket.



Armrest release lever **MUST** be in the unlocked position when placing armrest into the arm sockets.

4. Lock the swing-back arms by rotating the armrest release lever towards the inside of the wheelchair.

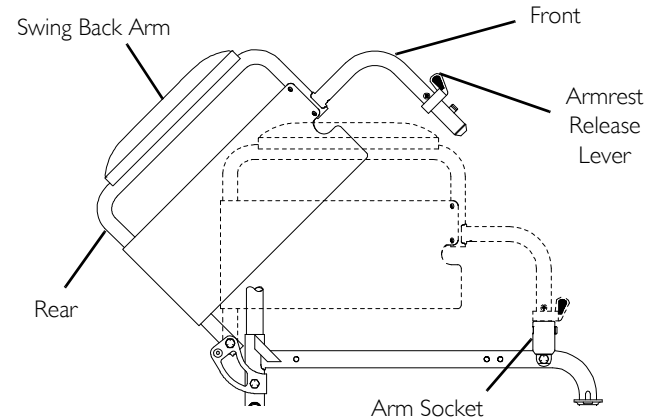

**FIGURE 7** Using Swing-Back Arms

## 5 OPERATION

### 5.6 Removing/Installing the Armrests



#### **WARNING**

9000XDT: Use only heavy duty, fixed height armrests on 9000XDT wheelchairs. Otherwise injury or damage may occur. Make sure the armrest release lever is in the locked position before using the wheelchair.



This procedure does not apply to 9000 SL wheelchairs equipped with space saver arms.

#### **Removing Armrests**

1. Unlock the armrest by turning the armrest release levers towards the outside of the wheelchair.
2. Lift armrest completely out of arm sockets from the wheelchair.

#### **Installing Armrests**



Armrest release lever **MUST** be in the unlocked position when placing armrest into the arm sockets.

1. Place armrest into arm sockets located on the side of the wheelchair.
2. Lock the armrest by turning the armrest release levers towards the inside of the wheelchair.

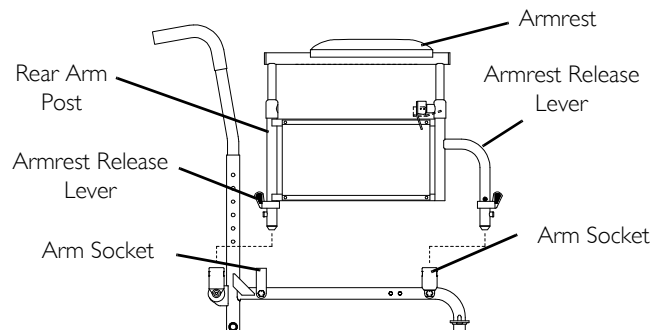

**FIGURE 8** Removing/Installing the Armrests

## 5.7 Removing/Installing Rear Wheels - Quick-Release Axels Only



### **WARNING**

Only a qualified technician may change the size of the rear wheel or the seat-to-floor height.

NEVER use quick-release axles on the 9000 XT (models with offset axle option only), 9000XDT or 9000XT recliner wheelchairs.

### **Permanent Axles**

If the wheelchair is equipped with permanent axles, removal/installation of the rear wheels **MUST** be performed by a qualified technician.



If replacing the same size rear wheel, note the mounting position on the wheelchair frame for proper reinstallation of the new rear wheel.

1. Push in the detent pin of quick-release axle (with wheel) and pull the axle out through the opening in the center of the rear wheel and axle spacer.



Axle spacer is used only if wheelchair is equipped with conventional arms.

2. Push in the detent pin of the quick-release axle again and pull the axle out of the rear wheel.
3. Repeat STEPS 1-2 for the opposite rear wheel.
4. To reinstall the rear wheel onto the wheelchair, reverse STEPS 1-3.



Make sure axle spacer is between rear wheel and wheelchair frame if wheelchair is equipped with conventional arms.

## 5 OPERATION



### WARNING

Make sure the detent pin and detent balls of the quick-release axle are fully released before operating the wheelchair. The detent balls **MUST** be protruding past the inside of the rear wheel axle bushing for a positive lock (Detail "A"). Keep detent balls clean.

Invacare recommends inserting quick-release axles with the detent pin to the inside of the wheelchair to prevent accidental release during contact activities.

5. If the detent balls are not protruding past the inside of the axle bushing or there is too much side-to-side movement of the rear wheel assembly, refer to [Adjusting Quick-Release Axle](#) on page 58.

### DETAIL "A" - DETENT BALLS AND DETENT PIN

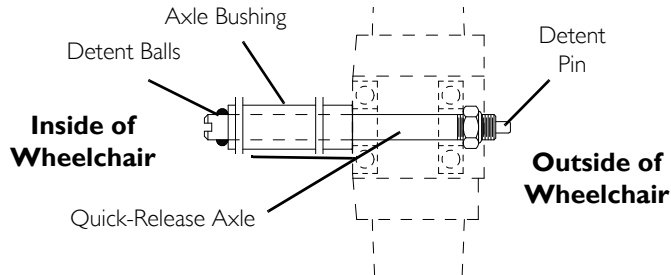

**FIGURE 9** Removing/Installing Rear Wheels - Quick-Release Axles Only

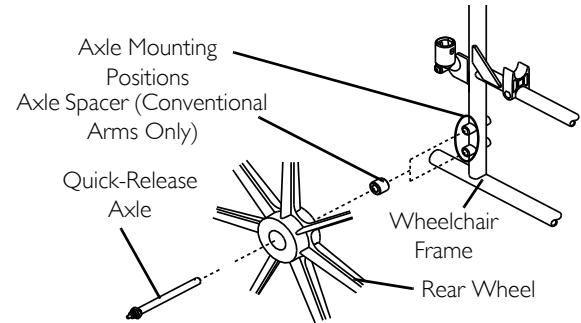

## 5.8 Installing Anti-tippers



### **WARNING**

Anti-tippers are specific to the different seat-to-floor angles and/or seat-to-floor heights. Refer to this procedure of the manual for correct usage and adjustment. If these requirements cannot be achieved, **DO NOT** use the wheelchair. Contact a qualified technician. If changing the seat-to-floor height with or without a change to seat-to-floor angle, the correct anti-tippers **MUST** be used to maintain a 1-1/2 to 2-inch ground clearance.

Seat-to-floor angle of 0° or 3°: If so equipped, anti-tippers **MUST** be attached at all times. Inasmuch as the anti-tippers are an option for 0° or 3° on this wheelchair (you may order with or without the anti-tippers), Invacare strongly recommends ordering the anti-tippers as a safeguard for the wheelchair user.

Seat-to-floor angle of 6°: If changing the seat-to-floor angle to 6°, anti-tippers **MUST** be ordered and installed.

Anti-tippers **MUST** be fully engaged and release buttons fully protruding out of adjustment holes.

Ensure both anti-tippers are adjusted to the same mounting hole.

Invacare strongly recommends that anti-tippers be used at all times.

The manual wheelchair is intended for indoor and outdoor use on firm surfaces. When outdoors on wet, soft ground or on gravel surfaces, anti-tippers may not provide the same level of protection against tip over. **DO NOT** operate on soft surfaces such as sand, grass or gravel.

## 5 OPERATION

1. Remove plug button (not shown) from end of rear frame tubing and install anti-rattles if not already installed.
2. Press the release buttons in and insert the anti-tippers with the anti-tipper wheels pointing toward the ground/floor into the rear frame tubing until the bottom release button locks in place.
3. Measure the distance between the bottom of the anti-tipper wheels and the ground/floor.



A 1½ to 2-inch clearance between the bottom of the anti-tipper wheels and the ground/floor **MUST** be maintained at all times.

4. If the distance between the bottom of anti-tipper wheels and the ground/floor is not 1½ to 2-inches, adjust anti-tippers. Refer to *Adjusting Anti-tippers* on page 59.

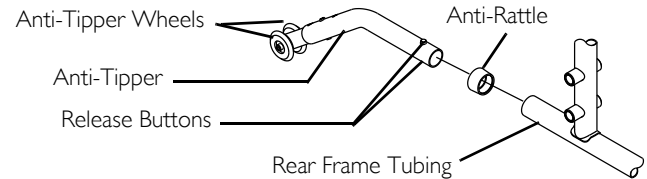

**FIGURE 10** Installing Anti-tippers

## 5.9 Using Patient Operated Wheel Locks



### WARNING

DO NOT attempt to stop a moving wheelchair with wheel locks. Wheel locks are not brakes.

If the wheelchair is equipped with push to lock wheel locks, elevating legrests, and wheel lock extension handles, the wheel lock extension handles MUST be removed before swinging the elevating legrests to the side, otherwise injury or damage may result. Interference between the top of the elevating legrest and the wheel lock extension handle may cause the wheel lock to disengage.



Position wheelchair on a flat, level surface to perform this procedure. Ensure the wheelchair is not moving before engaging the wheel locks.

1. See Detail “A” for instructions on Push-to-Lock. Refer to Detail “B” for instructions on Pull-to-Lock.
2. Disengage the wheel locks by reversing the directions in STEP 1.

### Detail “A” Push-To-Lock

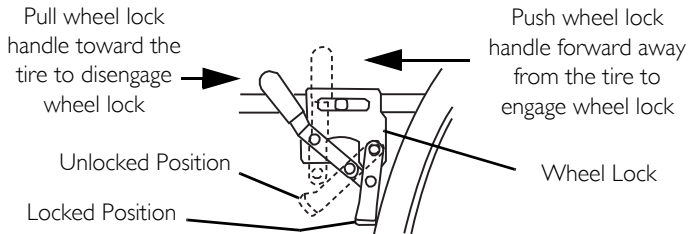

### Detail “B” - Pull-To-Lock

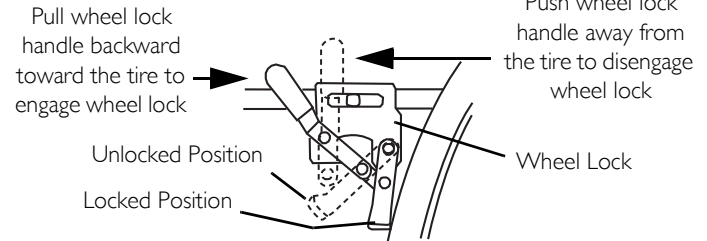

**FIGURE 11** Using Patient Operated Wheel Locks

## 5 OPERATION

### 5.10 Installing the Optional Wheel Lock Extension Handle



#### **WARNING**

If the wheelchair is equipped with push to lock wheel locks, elevating legrests, and wheel lock extension handles, the wheel lock extension handles **MUST** be removed before swinging the elevating legrests to the side, otherwise injury or damage may result. Interference between the top of the elevating legrest and the wheel lock extension handle causes the wheel lock to disengage.



For this procedure, refer to FIGURE 12

1. Remove the existing rubber tip from the wheel lock handle (Detail “A”).
2. Install the extension handle over the wheel lock handle (Detail “B”).

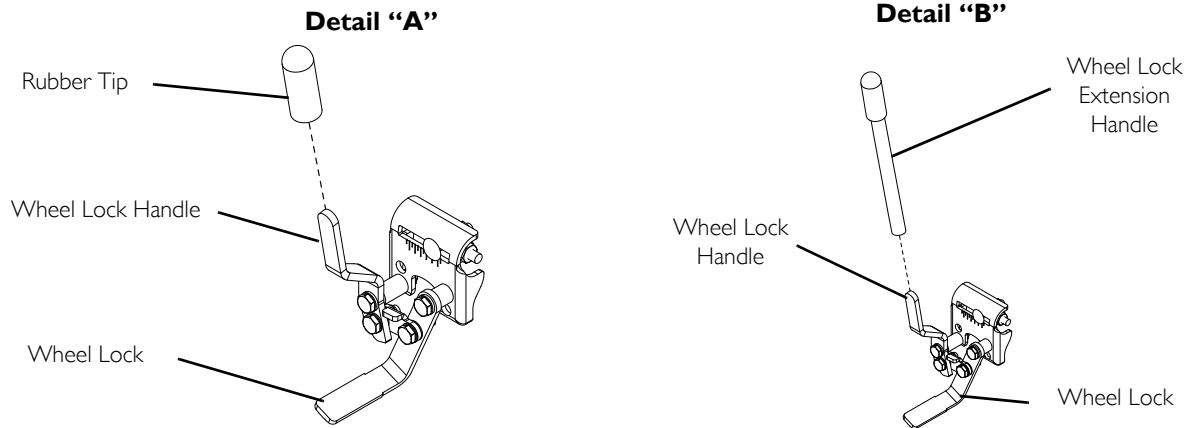

**FIGURE 12** Installing the Optional Wheel Lock Extension Handle



---

## 6 Recliner Operation

---

### 6.1 Operating Recliner



#### **WARNING**

ALWAYS make sure that the wheelchair is stable before using the recliner option.

ALWAYS wear your seat positioning strap. Inasmuch as the seat positioning strap is an option on this wheelchair (you may order with or without the seat positioning strap), Invacare strongly recommends ordering the seat positioning strap as an additional safeguard for the wheelchair user. The seat positioning strap is a positioning strap only. It is not designed for use as a safety device withstanding high stress loads such as auto or aircraft safety belts. If signs of wear appear, strap **MUST** be replaced **IMMEDIATELY**.

Ensure the spreader bar is attached and secured before using the 9000XT Recliner.

**LIFT KIT MODELS ONLY** - Both spring lift mechanisms **MUST** be operational before using the recliner. **DO NOT** operate the recliner option if only one of the spring lift mechanisms is operational.

**TO HEALTHCARE PROFESSIONALS/ASSISTANTS:**

Make sure occupant's hands and body are clear of all pinch points before reclining back. Pinch Points exist between spreader bar and recliner mechanism. Use caution, otherwise injury may occur.

When returning the occupant of the wheelchair to the full upright position, more body strength will be required for approximately the last twenty degrees of incline (reverse recline). Make sure to use proper body mechanics (use your legs) or seek assistance if necessary to avoid injury.

After any adjustments, repair or service and before use, make sure all attaching hardware is tightened securely. Otherwise injury or damage may occur.

Lift kit models only - **DO NOT** attempt to recline or incline the wheelchair back without occupant. Back will raise abruptly and cause injury. Keep clear when reclining or inclining (reverse recline) chair back to avoid injury.

ALWAYS engage both wheel locks while reclining or inclining (reverse recline) the wheelchair.

## 6 RECLINER OPERATION



### WARNING

Make sure the patient is properly positioned in the wheelchair before reclining or inclining (reverse recline) to maintain maximum stability and safety. Refer to *Stability (Recliner Models Only)* on page 24.

1. Unfold wheelchair. Refer to *Unfolding and Folding Wheelchair* on page 36.
2. Attach spreader bar. Refer to *Storing/Replacing Spreader Bar* on page 51.
3. Adjust the tightness of the headrest/back upholstery. Refer to *Adjusting Headrest/Back Upholstery Tension* on page 52.
4. Make sure wheelchair is occupied and on a level surface before reclining.
5. Engage the wheel locks. Refer to *Using/Adjusting Wheel Locks* on page 53.
6. Inform the occupant of the wheelchair that the wheelchair is about to be reclined.
7. Make sure occupant's hands and body are clear of all pinch points.
8. Stand behind the wheelchair and grasp both push handles firmly.
9. Squeeze release handles.
10. Slowly pull back on the back assembly while squeezing the release handles.
11. When the back reaches the desired angle, slowly let go of the release handles.
12. To return the back to the full upright position, reverse STEPS 8-11 keeping in mind proper body mechanics.

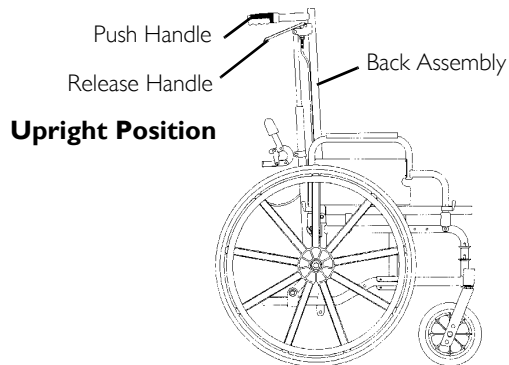

**Upright Position**

**Reclined Position**

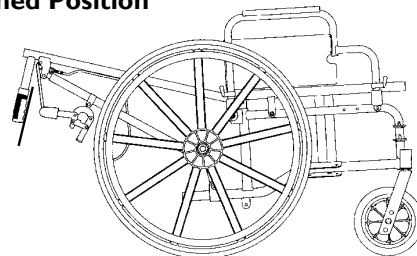

**FIGURE I** Operating Recliner

### 6.2 Storing/Replacing Spreader Bar

#### Storing Spreader Bar



The 9000XT Recliner is folded for either storage or transporting. One side of the spreader bar **MUST** be removed and placed in a vertical position alongside the recliner tube.

#### Removing From Stored Position

1. Rotate the end of the spreader bar 90° toward the opposite side frame.
2. Install threaded end of locking knob into locknut located on the opposite side frame. Securely tighten both knobs.

#### Placing In Stored Position

1. Remove one locking knob from the spreader bar.
2. Loosen the remaining locking knob on the spreader bar.
3. Rotate detached end of the spreader bar 90° down toward floor.

#### Replacing Spreader Bar

1. Remove both locking knobs that secure the spreader bar to the side frames.
2. Remove existing spreader bar.
3. Secure new spreader bar to the side frames with the existing locking knobs. Securely tighten.

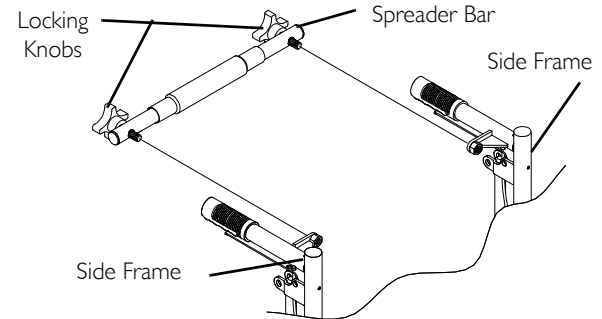
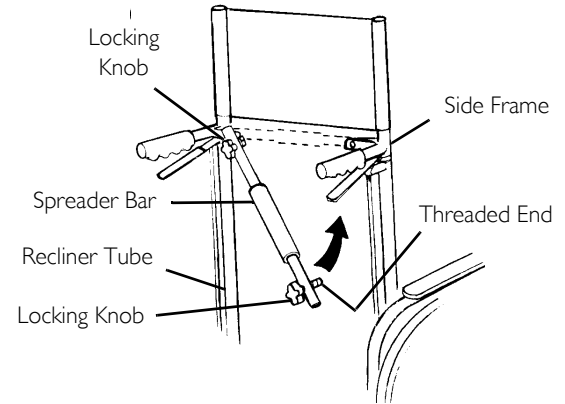
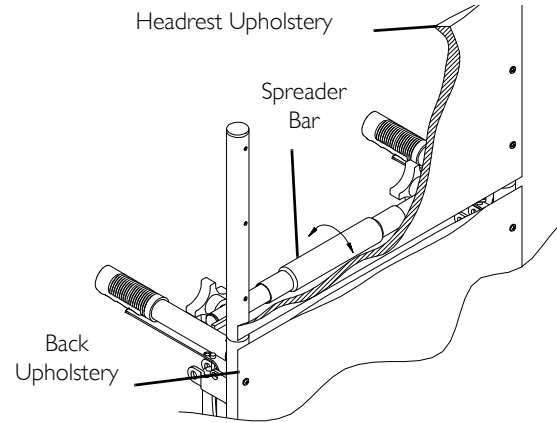

**FIGURE 2** Storing/Replacing Spreader Bar

## 6 RECLINER OPERATION

### 6.3 Adjusting Headrest/Back Upholstery Tension

1. Rotate the spreader bar in one of the following directions:
  - Counterclockwise (away from back upholstery) to loosen back/headrest upholstery.
  - Clockwise (towards back upholstery) to tighten back/headrest upholstery.



**FIGURE 3** Adjusting Headrest/Back Upholstery Tension

### 6.4 Replacing Headrest Pillow

1. Unfasten straps of headrest pillow from behind headrest upholstery.
2. Secure straps of the new headrest pillow onto fastening strips located on back of headrest upholstery.

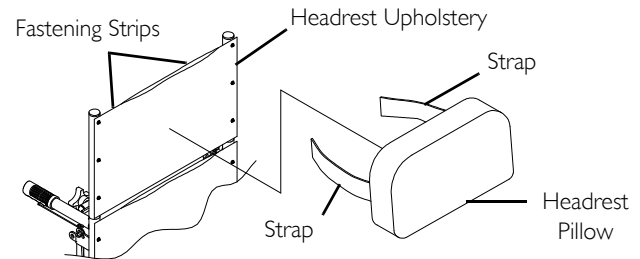

**FIGURE 4** Replacing Headrest Pillow

## 6.5 Using/Adjusting Wheel Locks



For using patient operated wheel locks, refer to [Using Patient Operated Wheel Locks](#) on page 47.

### Using Attendant Operated Wheel Locks



#### **WARNING**

DO NOT attempt to stop a moving wheelchair with wheel locks. Wheel locks are not brakes.

- I. Perform one of the following:
  - Engage - Apply pressure downward on wheel lock handle.
  - Disengage - Lift up on wheel lock handle.



**FIGURE 5** Using Attendant Operated Wheel Locks

## 6 RECLINER OPERATION

### 6.6 Installing Anti-Tippers

1. Install the anti-rattles onto the rear frame tubes if not already in place (Detail “A”).
2. Position the anti-tippers with the anti-tipper wheels pointing toward the ground/floor
3. Press the release buttons.
4. Insert the anti-tippers into the rear frame tubing until the bottom release button locks in place.



Refer to Detail “B” of FIGURE 6 and the following chart to ensure the correct anti-tipper is installed in the wheelchair. Seat-to-floor heights are approximate depending on front caster type. The anti-tipper height measurement **MUST** be taken with the anti-tipper on a flat surface.

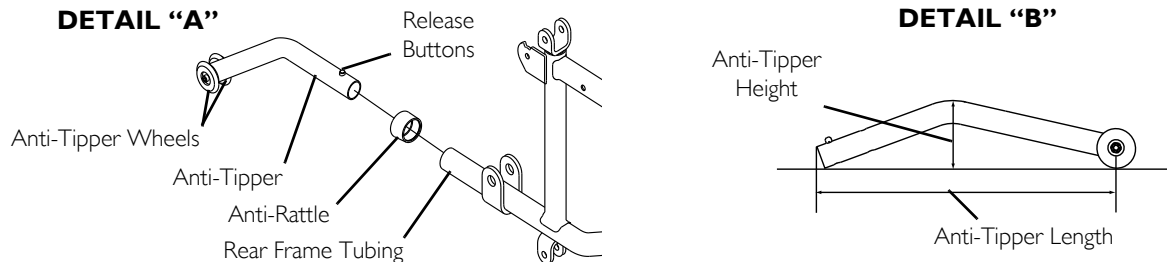

**FIGURE 6** Installing Anti-Tippers

#### 9000 XT RECLINER

Wheel Size Rear/Caster	Seat-to-Floor Height	Anti-Tipper Length/Height	On Chair	Off Chair Kit Number
24/8-inch	19½-inches	11½ / 2½-inches	1021767	1021767
22/8-inch	18½-inches	10¼ / 1-7/8-inches	1061110	1061110
20/8-inch	17½-inches	10 / 1½-inches	1061109	1061109

## 7 Adjustment



### WARNING

After any adjustments, repair or service and before use, make sure all attaching hardware is tightened securely. Otherwise injury or damage may occur.

### 7.1 Adjusting Armrest Height



### WARNING

Make sure the height adjustment lever is in the locked position before using the wheelchair.

1. Unlock the armrest by flipping the height adjustment lever on the top front of the armrest to the up (horizontal) position.
2. Adjust armrest to one of five positions.



Height adjustment lever **MUST** be in the unlocked position when placing armrest into the arm assembly.

3. Lock the armrest by pressing the height adjustment lever into the down (vertical) position when the desired armrest height is achieved.
4. Repeat STEPS 1-3 for other armrest.

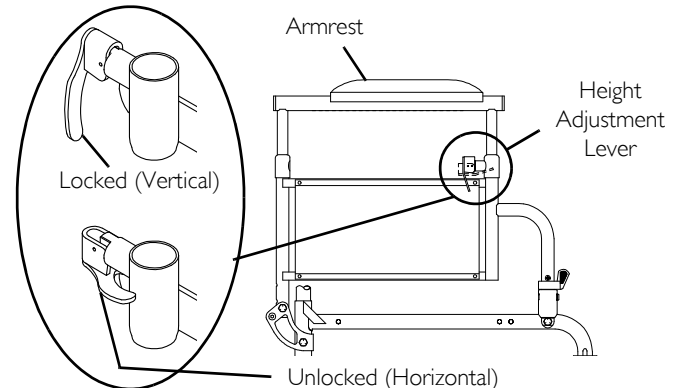

**FIGURE I** Adjusting Armrest Height

## 7 ADJUSTMENT

### 7.2 Adjusting Footplate Height

#### Spring Button Height

**i** This procedure applies to the swingaway front riggings and swingaway elevating legrest.

1. Remove the front rigging assembly. Refer to [Installing/Removing Front Riggings](#) on page 38.

**i** Lay the front rigging assembly on a flat surface to simplify this procedure.

2. Pull the cam lock lever up to unlocked position.

**i** The elevating legrest has two sets of release buttons, one set above the other. Each set will be visible one at a time allowing finer footplate height adjustment.

3. Push in the release buttons and reposition the footplate assembly to the desired height.

4. Ensure that the release buttons fully protrude from holes on both sides of the front rigging support.

5. Rotate cam lock lever down to locked position.

6. Repeat this procedure for the other footplate, if necessary.

7. Reinstall the swingaway front rigging assembly. Refer to [Installing/Removing Front Riggings](#) on page 38.

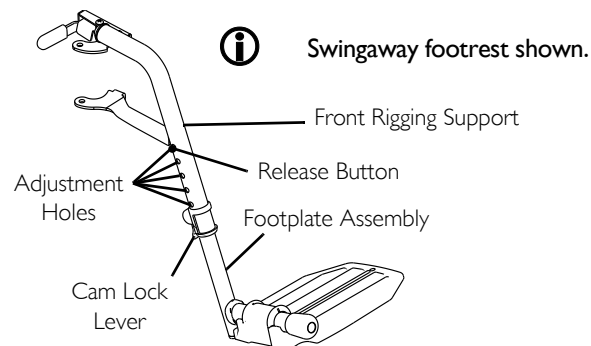

**FIGURE 2** Spring Button Height



**Bolt-In-Place Height**

This procedure applies to the swingaway front riggings and swingaway elevating legrest.

1. Remove the swingaway front rigging. Refer to Installing/Removing Front Rigging on page 38.



Lay the front rigging assembly on a flat surface to simplify this procedure.

2. Pull the cam lock lever up to position.
3. Using a screw driver to hold the threaded rivet in position, remove the button head screw from the threaded rivet.
4. Remove the threaded rivet and button head screw securing the footplate assembly to the front rigging support.
5. Adjust the footplate assembly height by aligning the desired adjustment holes in the upper front rigging support and lower footplate assembly.
6. From the outside of the swingaway front rigging, insert the threaded rivet through both the front rigging support and the footplate assembly.
7. From the inside of the swingaway front rigging, insert the button head screw through the appropriate adjustment hole and thread into the threaded rivet.
8. Using a screwdriver to hold the threaded rivet in position, securely tighten the button head screw. Torque to 32 in-lbs.
9. Rotate cam lock lever down to locked position.
10. Repeat STEPS 1-9 to adjust the remaining footrest.

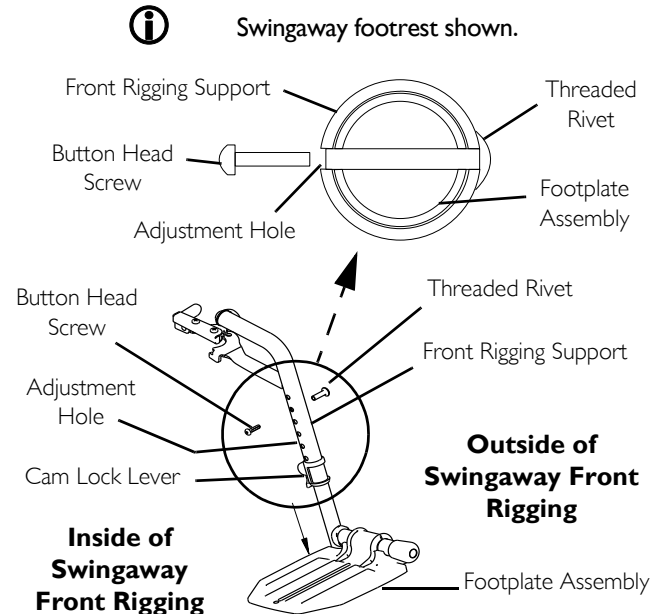

**FIGURE 3** Bolt-In-Place Height

## 7 ADJUSTMENT

### 7.3 Adjusting Quick-Release Axle



#### **WARNING**

NEVER use quick-release axles on the 9000 XT (models with offset axle option only), 9000XDT or 9000XT recliner wheelchairs.

1. Remove rear wheel and quick-release axle from the wheelchair. Refer to Removing/Installing Rear Wheels - Quick-Release Axels Only on page 43.
2. Depress detent pin in the quick-release axle and slide axle through the rear wheel hub.
3. Release detent pin ensuring that the detent balls are fully released.
4. Increase or decrease end play by adjusting the locknut on the end of the quick-release axle.



#### **WARNING**

Make sure detent pin and detent balls of the quick-release axles are fully released before operating the wheelchair.  
Keep detent balls clean.

5. Reinstall rear wheel onto the wheelchair. Refer to Removing/Installing Rear Wheels - Quick-Release Axels Only on page 43.

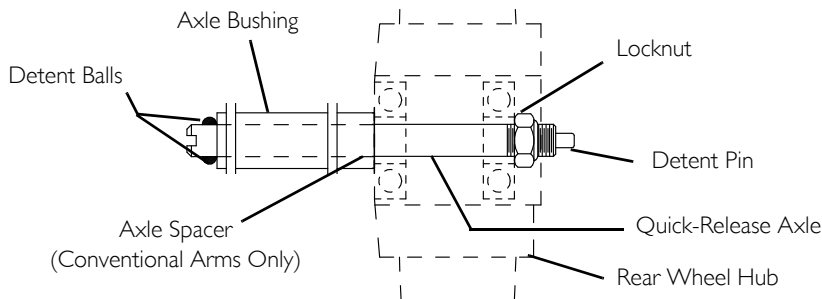

**FIGURE 4** Adjusting Quick-Release Axle

## 7.4 Adjusting Anti-tippers

**WARNING**

Anti-tippers are specific to the different seat-to-floor angles and/or seat-to-floor heights. Refer to this procedure of the manual for correct usage and adjustment. If these requirements cannot be achieved, **DO NOT** use the wheelchair. Contact a qualified technician. If changing the seat-to-floor height with or without a change to seat-to-floor angle, the correct anti-tippers **MUST** be used to maintain a 1-1/2 to 2-inch ground clearance.

Anti-tippers **MUST** be fully engaged and release buttons fully protruding out of adjustment holes. Ensure both anti-tippers are adjusted to the same mounting hole.

1. Press the release buttons on the wheeled portion of the anti-tipper and slide it up or down to achieve the 1-1/2 to 2-inch clearance (Detail "A").
2. Check to make sure that the release buttons are fully engaged in adjustment holes.

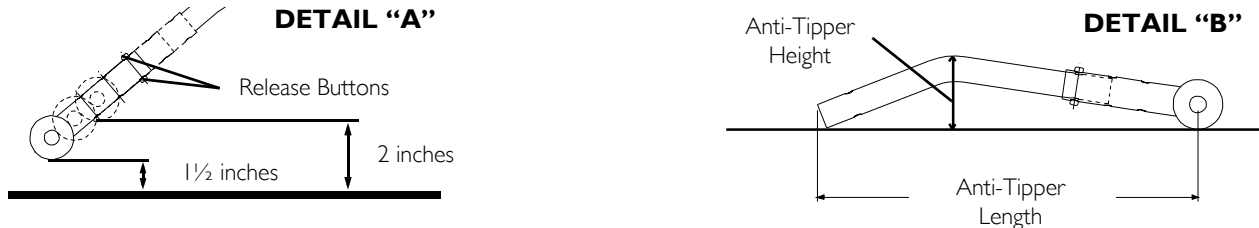

**FIGURE 5** Adjusting Anti-tippers



Refer to Detail "B" in FIGURE 5 and to the following charts to ensure the correct anti-tipper is installed in the wheelchair. Seat-to-Floor heights are approximate depending on front caster size and type. Anti-Tipper length measurement is taken with the extension tube in the longest position available. The anti-tipper height measurement **MUST** be taken with the anti-tipper on a flat surface.

## 7 ADJUSTMENT

9000 XT (SUPER LOW FRAME)				
CASTER SIZE	SEAT-TO-FLOOR HEIGHT	ANTI-TIPPER LENGTH/HEIGHT	ON CHAIR	OFF CHAIR KIT NUMBER
6-inch	13½ and 14½ inches	10½ / 2-inches	I360SH	I064520

9000 XDT (ADULT TALL FRAME)				
CASTER SIZE	SEAT-TO-FLOOR HEIGHT	ANTI-TIPPER LENGTH/HEIGHT	ON CHAIR	OFF CHAIR KIT NUMBER
8-inch	17½ and 19½ inches	11-5/8 / 2-3/4-inches	I360A	I058752
8-inch	21½-inches	13½ / 3½-inches	I360	I058836

9000 XT WITH 0° SEAT-TO-FLOOR ANGLE (ADULT/HEMI FRAME)				
CASTER SIZE	SEAT-TO-FLOOR HEIGHT	ANTI-TIPPER LENGTH/HEIGHT	ON CHAIR	OFF CHAIR KIT NUMBER
8-inch	17½, 18½ inches	13½ / 3½-inches	N/A	I058836
6-inch	16½, 17½-inches	13½ / 3½-inches	N/A	I058366
	15½-inches	11-5/8 / 2-3/4-inches	N/A	I058752

9000 XT WITH 3° SEAT-TO-FLOOR ANGLE AND 9000 SL (ADULT/HEMI FRAMES)				
CASTER SIZE	SEAT-TO-FLOOR HEIGHT	ANTI-TIPPER LENGTH/HEIGHT	ON CHAIR	OFF CHAIR KIT NUMBER
8-inch	17½, 18½, 19½-inches	13½ / 3½-inches	I360	I058836
6-inch	15½, 16½, 17½-inches	11-5/8 / 2¾-inches	I360A	I058752

9000 XT WITH 6° SEAT-TO-FLOOR ANGLE (ADULT/HEMI FRAME)				
CASTER SIZE	SEAT-TO-FLOOR HEIGHT	ANTI-TIPPER LENGTH/HEIGHT	ON CHAIR	OFF CHAIR KIT NUMBER
8-inch	17½, 18½, 19½-inches	13½ / 2-7/8-inches	N/A	1113766
6-inch	16½, 17½-inches	12½ / 2¾-inches	N/A	1113765
	15½-inches	9½ / 2-3/8-inches	N/A	1113764

### 7.5 Adjusting Patient-Operated Wheel Locks



The push-or-pull-to-lock wheel locks are also an option on the 9000XT Recliner.

If wheels are pneumatic, before adjusting or replacing the wheel lock assemblies, ensure that the tires are inflated to the recommended psi on the side wall of tire. The recommended tire pressure is located on the side wall of the tire.

1. Disengage the wheel locks.
2. Perform one of the following:
  - Bolt-on Wheel locks - Loosen the bolt and locknut that secure the wheel lock to the wheelchair frame.
  - Clamp-on wheel locks - Loosen the two socket screws that secure the wheel lock to the wheelchair frame.
3. Reposition the wheel lock so that when engaged, the wheel lock shoe embeds the tire 1/8-inch (3/16-inch for pneumatic tires) and holds the occupied wheelchair in place when pushed.
4. Securely tighten the bolt and locknut or socket screws securing the wheel lock to the wheelchair frame.
5. Engage the wheel lock.

## 7 ADJUSTMENT

6. Measure the distance the wheel lock is embedded into the tire as shown in FIGURE 6 on page 62.



Any wheel lock adjustment should embed the wheel lock shoe at least 1/8-inch (3/16-inch if pneumatic tire) into the tire when engaged.

7. Repeat STEPS 1-6 until the wheel lock shoe embeds the tire 1/8-inch (3/16-inch for pneumatic tires) and holds the occupied wheelchair in place when pushed.
8. If the measurement of 1/8-inch (3/16-inch for pneumatic tires) can not be achieved, Perform one of the following:
- Bolt-on wheel locks - Remove the bolt and locknut that secure the wheel lock to the wheelchair frame and mount the wheel lock in the remaining mounting position.
  - Clamp-on Wheel locks - Proceed to STEP 9.
9. If wheel lock is unable to properly engage the wheel it may be necessary to install wheel lock shoe extensions. Contact a qualified technician/dealer.
10. Repeat STEPS 1-9 for the opposite wheel lock.
11. Engage both wheel locks and ensure the occupied wheelchair is held in place when pushed.



### WARNING

If wheel locks DO NOT hold the occupied wheelchair in place, contact a qualified technician. Otherwise injury or damage may occur.

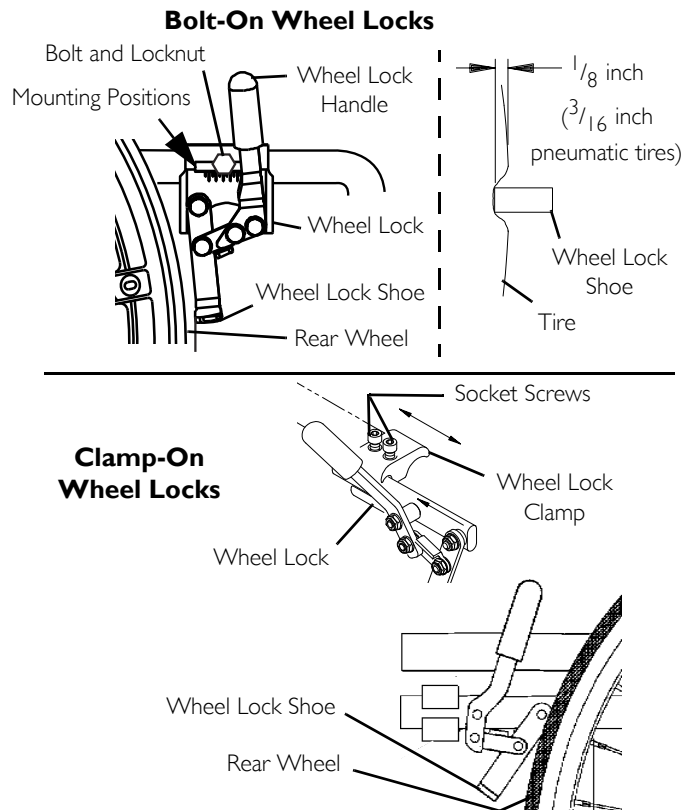

**FIGURE 6** Adjusting Patient-Operated Wheel Locks

## 7.6 Adjusting Attendant Operated Wheel Locks



If wheels are pneumatic, before adjusting or replacing the wheel lock assemblies, ensure that the tires are inflated to the recommended psi located on the side wall of tire.

1. Loosen the bolt and locknut that secure the wheel lock to the recliner tube.
2. Adjust the position of wheel lock so that when engaged, the wheel lock shoe embeds the tire 1/8-inch (3/16-inch for pneumatic tires) and holds the wheelchair.
3. Securely tighten the bolt and locknut.
4. Engage wheel lock and push against the wheelchair and determine if wheel lock engages the wheel lock shoe enough to hold the wheelchair.
5. Repeat the above procedures until the wheel lock holds the wheelchair.
6. Repeat STEPS 1-5 for the opposite wheel lock.



Ensure the wheel lock shoe completely covers the tire contact area. See Detail "A" for proper positioning of wheel lock shoe.

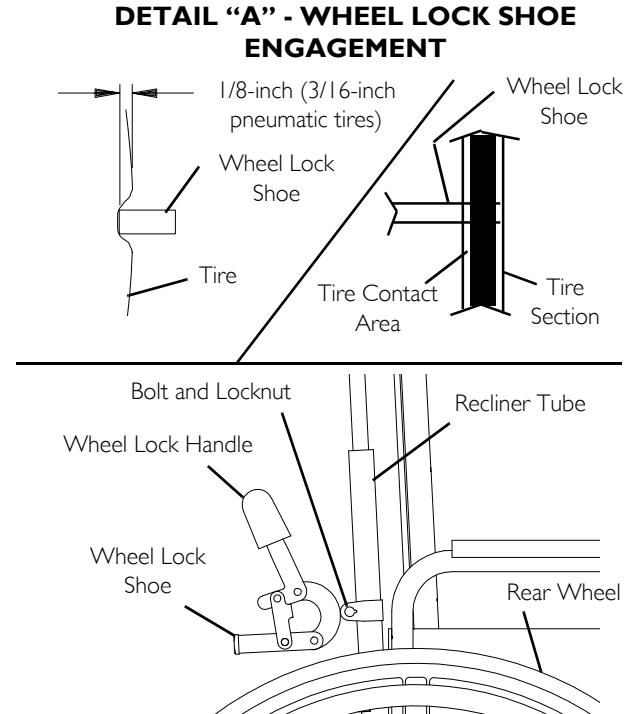

**FIGURE 7** Adjusting Attendant Operated Wheel Locks

## 8 TROUBLESHOOTING/MAINTENANCE

### 8 Troubleshooting/Maintenance

#### 8.1 Troubleshooting

Chair Veers Right/Left	Chair 3 Wheels	Sluggish Turn or Performance	Casters Flutter	Squeaks and Rattles	Looseness in Chair	Solutions
X	X	X	X			Check tires for correct and equal pressure
		X	X	X	X	Check for loose nuts and bolts.
X	X		X			Check caster headtube angle.
X	X					Check that rear wheels are equally spaced away from seat frame.



## 8.2 Maintenance

### Maintenance Safety Precautions



#### **WARNING**

After any adjustments, repair or service and before use, make sure all attaching hardware is tightened securely. Otherwise injury or damage may result.

Replace any labels that are missing, worn, or torn. Refer to [Label Locations](#) on page 8 for a listing of the labels and their locations.

#### **CAUTION**

DO NOT overtighten hardware attaching to the frame. This could cause damage to the frame tubing.

### Suggested Maintenance Procedures

1. Before using your 9000 Series wheelchair, make sure all nuts and bolts are tight.
2. Check all parts for damage or wear and replace.
3. Check all parts for proper adjustment.
4. 9000 SL/9000 XT ONLY - Keep quick-release axles free of dirt and lint to ensure positive locking and proper operation. Refer to [Adjusting Quick-Release Axle](#) on page 60.
5. 9000 SL/9000 XT ONLY - Oil quick-release axles at least once a month (3-in-1 oil<sup>®</sup> or equivalent).



#### **WARNING**

Do not use the wheelchair unless it has the proper tire pressure (p.s.i.).

DO NOT overinflate the tires. Failure to follow these suggestions may cause the tire to explode and cause bodily harm. The recommended tire pressure is listed on the sidewall of the tire.

## 8 TROUBLESHOOTING/MAINTENANCE



### CAUTION

As with any vehicle, check the wheels and tires periodically for cracks and wear. Replace if damaged. Replace as recommended, refer to Replacing/Repairing Rear Wheel Tire/Tube on page 66 and Replacing/Repairing Caster Tire/Tube on page 67.

6. The rear wheels, casters and tires should be checked periodically for cracks and wear, and should be replaced by a qualified technician if damaged
7. Periodically adjust wheel locks in correlation to tire wear. Refer to Adjusting Patient-Operated Wheel Locks on page 68.



Tire wear is excessive if:

Pneumatic Tires - there is missing tread or the tires are bald.

Urethane Tires - there are cuts, surface defects or the tires are loose on the rims.

Rubber Tires - 30% or more of the tire has worn away.

Invacare recommends that tires and casters be replaced every five years.

8. Periodically check handrims to ensure they are secured to the rear wheels. If loose, have them tightened by a qualified technician.
9. Periodically check caster wheel bearings to make sure they are clean and free from moisture. Use a Teflon<sup>®</sup> lubricant if necessary.
10. Check upholstery for sagging, rips or tears.
11. Clean upholstery with mold soap and water
12. Hand grips should be checked monthly for wear/looseness/deterioration. Clean if desired. Replace if looseness or deterioration is found.

### Replacing/Repairing Rear Wheel Tire/Tube



### WARNING

Replacement of solid urethane tires is not recommended. If the solid urethane tire needs repaired, Invacare recommends replacing the complete wheel assembly.

Replacement of rear wheel tube must be performed by a qualified technician.

### Replacing/Repairing Caster Tire/Tube



#### **WARNING**

Replacement of solid urethane or semi-pneumatic tires is not recommended. If the solid urethane or semi-pneumatic tires need replaced, Invacare recommends replacing complete caster assembly.

For pneumatic tires, replacement of the tire or tube must be performed by a qualified technician.

### 8.3 Cleaning Instructions



#### **CAUTION**

##### **Risk of Damage**

Spraying the wheelchair with water or any type of liquid may permanently damage the electronics such as ventilators and communication devices.

– NEVER spray the wheelchair with any type of water or liquid.



Regular cleaning will reveal loose or worn parts and enhance the smooth operation of your wheelchair. To operate properly and safely, your wheelchair must be cared for just like any other vehicle.

For upholstery that is severely stained or surface finish that is badly damaged, contact the seating system manufacturer for further information.

### **Cleaning Upholstery, Cloth, Vinyl**

For cleaning upholstery, refer to the seating user manual shipped with the product.

### **Cleaning Metal Surfaces**

Hot water and a mild detergent on soft cloth should be used for cleaning metal surfaces. Wipe down with damp cloth. Dry surface by wiping down with dry cloth.

Car polish and soft wax can be used to remove abrasions and restore gloss (Follow manufacturer's instructions).

## 8 TROUBLESHOOTING/MAINTENANCE

### Cleaning Plastic Surfaces

Plastic surfaces should be cleaned with soft cloth, mild detergent, and hot water. Rinse surface with clean water. Dry surface with soft cloth. Solvents or kitchen cleaners must not be used on plastic surfaces.

### Cleaning I.V. Rod/O<sub>2</sub> Holder



#### **WARNING**

The user and O<sub>2</sub> cylinder **MUST** be removed from the wheelchair when cleaning the O<sub>2</sub> holder. Otherwise, injury or damage may occur if cleaning agents come in contact with the O<sub>2</sub> regulator.

1. Remove the user, any I.V. medication and the O<sub>2</sub> cylinder from the wheelchair.
2. The telescoping I.V. rod/O<sub>2</sub> holders clean easily with any household glass type cleaner.
3. After the cleaning solution has dried, it is safe for the user to re-occupy the wheelchair.

## 9 Service

### **!** **IMPORTANT**

This section of the user manual provides service instructions for this product. All procedures in this section **MUST** be performed by a qualified technician/dealer.

For any service requirements beyond these procedures contact Invacare.

For a list of parts or part numbers contact your dealer/Invacare.

**DO NOT** return product without first contacting your dealer/Invacare for shipping and packing instructions.

If necessary, contact Invacare for a list of dealers.



### **DANGER**

#### **Risk of Death, Serious Injury or Damage**

Use of incorrect or improper replacement (service) parts may cause death, serious injury, or damage.

Replacement parts **MUST** match original Invacare parts.

**ALWAYS** provide the wheelchair serial number to assist in ordering the correct replacement parts.



### **WARNING**

#### **Risk of Serious Injury**

A non-qualified technician performing service procedures on this wheelchair can result in serious injury.

A qualified technician **MUST** perform all procedures in this section of the manual.



### **WARNING**

Unless otherwise noted, all service and adjustment should be performed while the wheelchair is unoccupied.

After **ANY** adjustments, repair or service and **BEFORE** use, make sure all attaching hardware is tightened securely - otherwise injury or damage may result.

## 9 SERVICE



**TOOLS:** Performing procedures in this section may require the use of tools including:

Flat blade and philips head screwdrivers, standard and or metric socket set/wrenches, torque wrench, hex (Allen) keys and side cutters.

### 9.1 Replacing Heel Loop

1. Pull the cam lock lever up to unlocked position.
2. Perform one of the following as shown in Detail “A”.
  - Footplates with Spring Buttons: Push in the release buttons and remove the footplate assembly from the front rigging support.
  - Bolt-In-Place Footplates:
    - i. Using a screw driver to hold the threaded rivet in position, remove the button head screw from the threaded rivet.
    - ii. Remove the threaded rivet and button head screw securing the footplate assembly to the front rigging support.
3. Remove the mounting screw, spacer and locknut that secure the heel loop to the footplate.
4. Remove existing heel loop from slide tube.
5. Install new heel loop onto slide tube.
6. Install the mounting screw, spacer and locknut to secure the heel loop to the footplate. Tighten until the spacer is secure.
7. Insert the lower footrest assembly into the upper footrest assembly to desired height.
8. Perform one of the following as shown in Detail “A”:
  - Footplates With Spring Buttons: Ensure that the release buttons fully protrude from holes on both sides of the upper footrest support.
  - Bolt-In-Place Footplates:
    - i. From the outside of the swingaway front rigging, insert the threaded rivet through both the front rigging support and the footplate assembly.
    - ii. From the inside of the swingaway front rigging, insert the button head screw through the appropriate adjustment hole and thread into the threaded rivet.
    - iii. Using a screwdriver to hold the threaded rivet in position, securely tighten the button head screw. Torque to 32 in-lbs.
9. Rotate cam lock lever down to locked position.

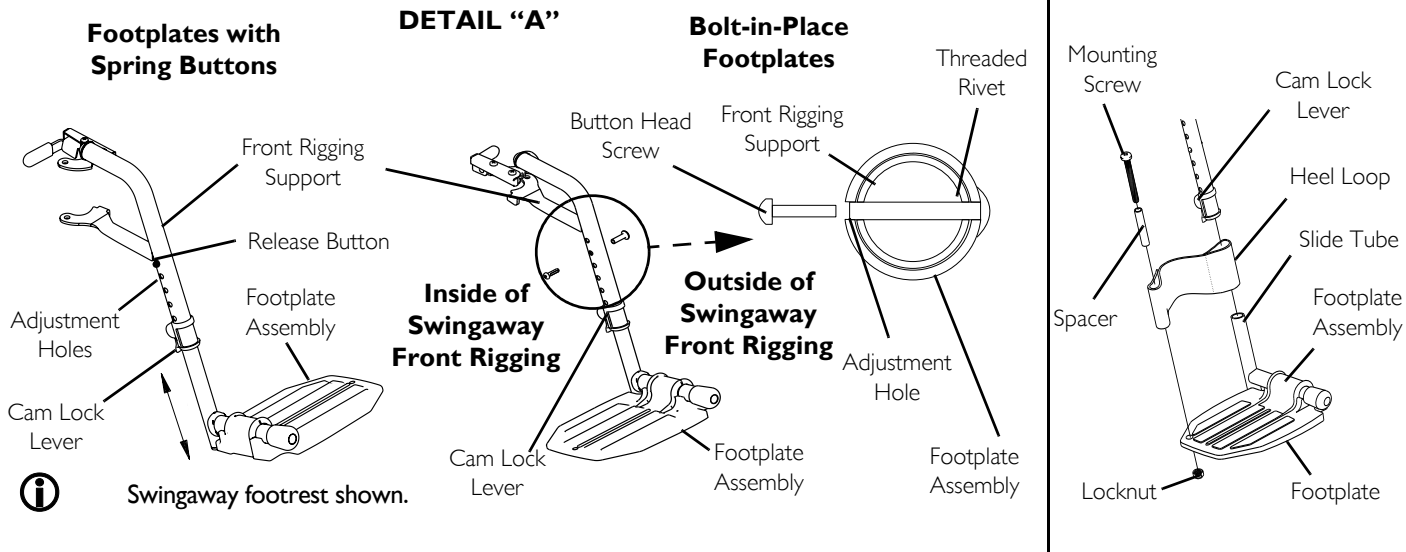

**FIGURE 1** Replacing Heel Loop

## 9 SERVICE

### 9.2 Replacing Desk/Full Length Armrest Pad (Fixed Height Arms Only)

1. Remove the mounting screws that secure the armrest pad to the armrest assembly.
2. Replace armrest pad and securely tighten with the existing mounting screws.

### 9.3 Replacing Clothing Guards (Fixed Height Arms Only)

1. Remove the four mounting screws that secure the existing clothing guard to the armrest assembly.
2. Install new clothing guard and securely tighten with the existing mounting screws.

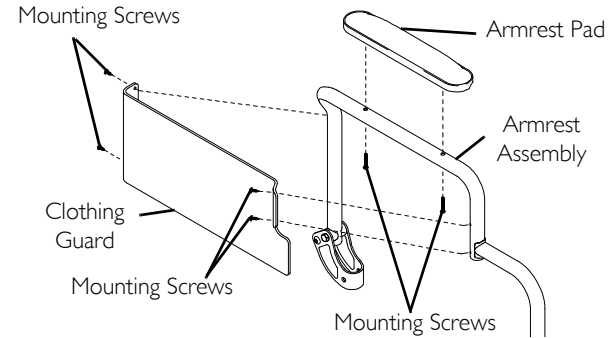

**FIGURE 2** Replacing Desk/Full Length Armrest Pad (Fixed Height Arms Only)

### 9.4 Converting Between Space Saver and Conventional Arms



Space Saver arms DO NOT work with 9000XT/9000SL with the adjustable angle back option and 9000XT Recliner.

1. Remove the arms from the wheelchair. Refer to [Removing/Installing the Armrests](#) on page 42.
2. Remove the locknut and hex screw that secure the arm socket to the wheelchair frame.
3. Repeat STEP 2 for the opposite side of the wheelchair.



4. Reposition the arm socket to one of two positions:
  - A. For conventional arms - position arm socket on outside of frame.
  - B. For space saver arms - position arm socket on inside of frame.

**i** Make sure arm sockets sit flush against the wheelchair frame.

5. Reinstall the hex screw and locknut that secure the arm socket to the wheelchair frame and securely tighten.
6. Repeat STEP 5 for the opposite side of the wheelchair.
7. Install the new arms onto the wheelchair. Refer to [Removing/Installing the Armrests](#) on page 42.

**i** The rear wheel axle spacer is needed for conventional arms. It is not needed for spacer saver arms.

8. For conventional arms, refer to [Removing/Installing Rear Wheels](#) on page 57.

### Space Saver Arm Position

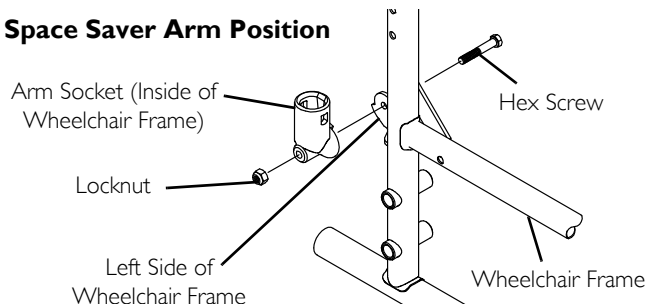

### Conventional Arm Position

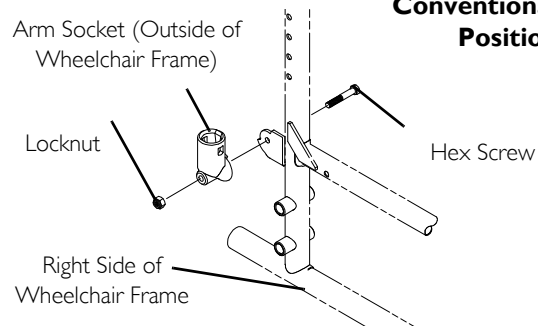
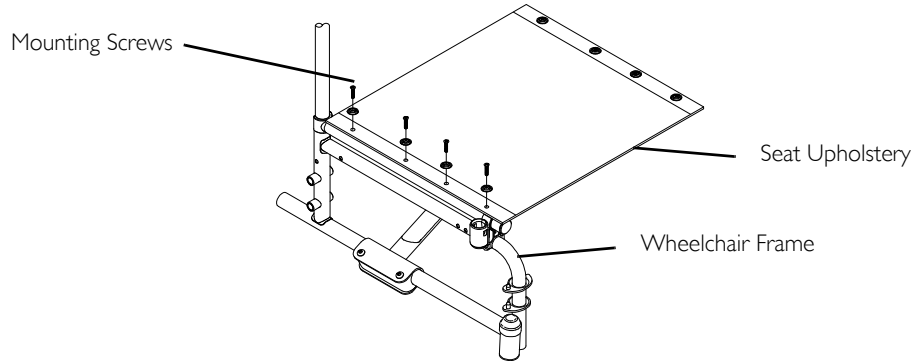

**FIGURE 3** Converting Between Space Saver and Conventional Arms

## 9 SERVICE

### 9.5 Replacing Seat Upholstery

1. Remove the mounting screws that secure the existing seat upholstery to the wheelchair frame.
2. Remove the existing seat upholstery from the wheelchair frame.
3. Install new seat upholstery by reversing STEPS 1-2.



**FIGURE 4** Replacing Seat Upholstery

## 9.6 Replacing Back Upholstery

### Screw-On Back Upholstery



This procedure applies to 9000 SL without adjustable back angle option.

1. Flip swing-back arms up and out of the way. Refer to [Using Swing-Back Arms](#) on page 41.
2. Remove the six mounting screws and washers that secure the existing back upholstery to the back canes.
3. Cut the tie wraps that secure the existing back upholstery to the wheelchair frame.
4. Securely tighten the new back upholstery to the back canes with the six mounting screws and washers starting with the top hole of the back cane.
5. Install two new tie wraps through the bottom holes of the upholstery to tie the bottom of the back upholstery to the back canes.
6. Flip swing-back arms down for use. Refer to [Using Swing-Back Arms](#) on page 41.

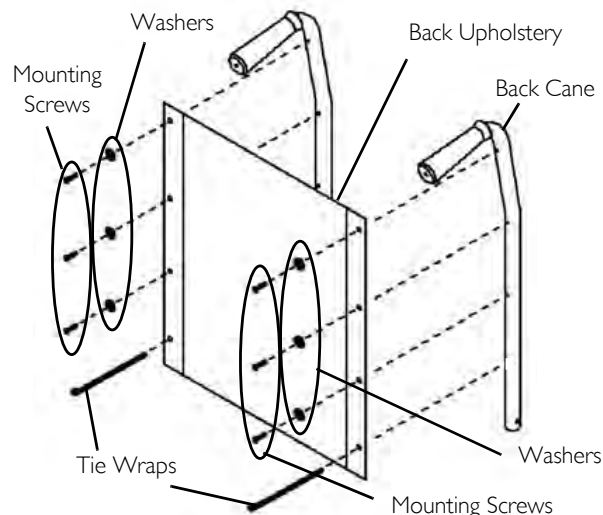

**FIGURE 9.1** Replacing Back Upholstery - Screw-On Back Upholstery

## 9 SERVICE

### Slip-On Back Upholstery



This procedure applies to 9000 XT/XDT and 9000 SL with adjustable back angle option.

1. Remove the two mounting screws and washers that secure the existing back upholstery to the back canes (Detail "A").
2. Remove the two mounting screws, spacers and locknuts that secure one back cane to the wheelchair frame (Detail "B").



It is necessary to remove only one back cane to replace the back upholstery.

3. Pull the loose back cane out of the existing back upholstery.
4. Pull the existing back upholstery up and over the mounted back cane.
5. Install the new back upholstery over the mounted back cane.
6. Slide the loose back cane through the new back upholstery.
7. Secure the back cane to the wheelchair frame with the two mounting screws, spacers and locknuts.



The spacers **MUST** be on the outside of the wheelchair in order to properly tighten the mounting screws.

8. Secure the new back upholstery to the back canes with the existing mounting screws and washers.

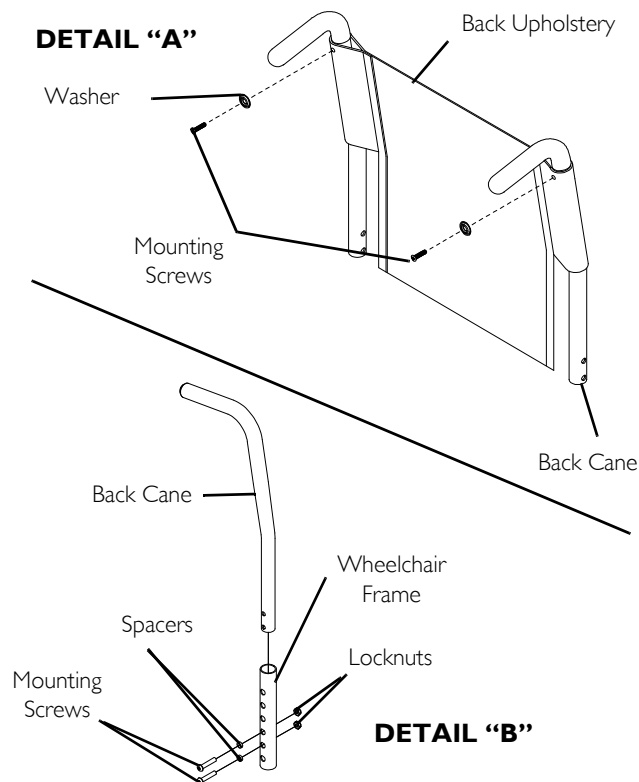

**FIGURE 9.2** Replacing Back Upholstery - Slip-On Back Upholstery

### 9.7 Adjusting Back Height, Back Angle or Seat Depth



#### **WARNING**

The seat depth, back height/angle, seat angle, size/position of the front casters, size/position of the rear wheels, anti-tipper model, as well as the user condition directly relate to the stability of the wheelchair. Any change to one or any combination of the ten may cause the wheelchair to decrease in stability. These adjustments must be performed by a qualified technician.

### 9.8 Adjusting Seat Width



#### **WARNING**

Adjusting the seat width of the 9000SL, 9000XT, 9000XDT MUST be performed by a qualified technician.

### 9.9 Removing/Installing Rear Wheels



#### **WARNING**

Changing the size of the rear wheel or the seat-to-floor height MUST be performed only by a qualified technician.



Use this procedure to replace a rear wheel with one of the same size.

The following procedures apply to wheelchairs with permanent axles. For wheelchairs with quick release axles refer to Removing/Installing Rear Wheels - Quick-Release Axels Only on page 43.

## 9 SERVICE

### With Patient Operated Wheel Locks

1. Remove the axle mounting screw and locknut that secure the patient operated wheel lock, spacers, and rear wheel to the wheelchair frame.
2. Secure rear wheel, patient operated wheel lock, and spacers to wheelchair frame with axle mounting screw and locknut. Securely tighten.
3. Adjust the patient operated wheel locks. Refer to [Adjusting Patient-Operated Wheel Locks](#) on page 68.

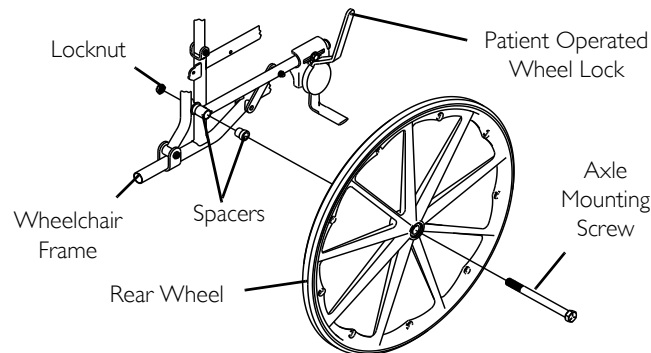

**FIGURE 10** Removing/Installing Rear Wheels - With Patient Operated Wheel Locks

### With Attendant Operated Wheel Locks

1. Remove the axle mounting screw and locknut that secure the rear wheel and spacer to the wheelchair frame.
2. Remove rear wheel from side frame.
3. Secure rear wheel and spacer to wheelchair frame with axle mounting screw and locknut. Securely tighten.
4. Adjust the attendant operated wheel locks. Refer to [Adjusting Attendant Operated Wheel Locks](#) on page 63.

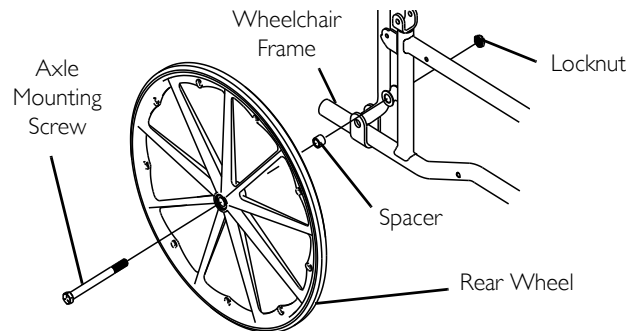

**FIGURE 11** Removing/Installing Rear Wheels - With Attendant Operated Wheel Locks

## 9.10 Replacing Rear Wheel Handrim



### WARNING

Wheelchairs with 300lbs weight limit: **DO NOT** use composite handrims. Otherwise injury or damage may occur. If the wheelchair is equipped with permanent axles, this procedure must be performed by a qualified technician.

1. Remove the rear wheel from the wheelchair. For non-recliner models, refer to [Refer to Removing/Installing Rear Wheels](#) on page 77. For 9000XT Recliner, refer to [Removing/Installing Rear Wheels](#) on page 79.
2. Remove the mounting screws that secure the handrim to rear wheel.
3. Remove the existing handrim.
4. Install the new handrim by reversing the preceding steps.



### WARNING

Make sure detent pin and detent balls of the quick-release axles are fully released before operating the wheelchair.

5. Reinstall rear wheel to the wheelchair. Refer to [Removing/Installing Rear Wheels](#) on page 77.
6. If the detent balls of the quick-release axles (if applicable) are not protruding past the inside of the axle bushing or there is too much movement of the rear wheel assembly in a back and forth position, refer to [Adjusting Quick-Release Axle](#) on page 58.
7. Repeat STEPS 1-6 for the opposite rear wheel if necessary.

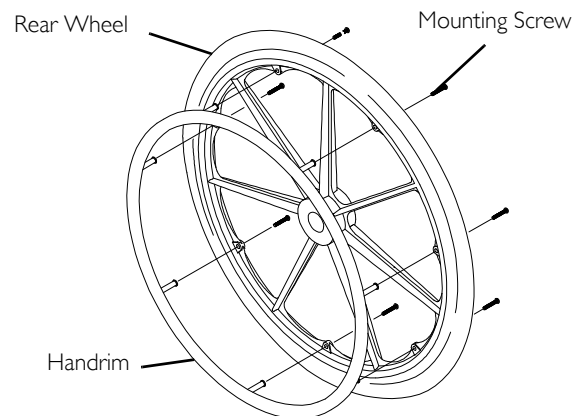

**FIGURE 9.1** Replacing Rear Wheel Handrim

## 9 SERVICE

### 9.11 Installing/Replacing Six or Eight-Inch Front Casters and Forks



#### **WARNING**

If converting from a six-inch caster to an eight-inch caster or vice versa, there are seat-to-floor height adjustments that **MUST** be made. Therefore, this procedure **MUST** be performed by a qualified technician.



This procedure can be performed if replacing the exact same size front caster.

1. Remove the dust cover.
2. Remove the locknut that secures the fork to the caster headtube.
3. Drop the front caster and fork out of the caster headtube.



**9000XDT ONLY** - Make sure to reinstall the 2-inch extension spacer. See Detail "A".

4. Slide in the new six/eight-inch front caster and fork.
5. Reassemble by reversing STEPS 1-3.
6. Repeat STEPS 1-5 for the opposite front caster.
7. To properly tighten caster journal system and guard against flutter, perform the following check:
  - A. Tip back of wheelchair to floor.
  - B. Pivot both forks and casters to top of their arc simultaneously.
  - C. Let casters drop to bottom of arc (wheels should swing once to one-side, then **IMMEDIATELY** rest in a straight downward position).
  - D. Adjust locknuts according to freedom of caster swing.
8. Test wheelchair for maneuverability.
9. Readjust locknuts if necessary, and repeat STEPS 7-8 until correct.
10. Snap dust cover over the locknut and stem.



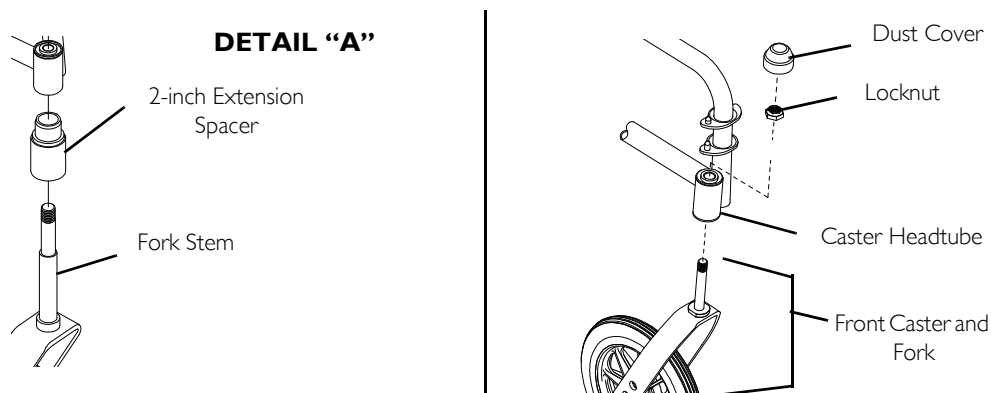

**FIGURE 10** Installing/Replacing Six or Eight-Inch Front Casters and Forks

### 9.12 Adjusting Front Caster Mounting



#### **WARNING**

Front Caster mounting adjustments **MUST** be performed by a qualified technician.

## 9 SERVICE

### 9.13 Installing Wheel Lock Shoe Extensions

1. Loosen the two set screws on the wheel lock shoe extension until the set screws DO NOT protrude into the slot.
2. Insert the disk wheel lock shoe into the slot in the shoe extension.



Ensure the pointed end of the wheel lock shoe extension is facing toward the rear wheel.

3. Position the wheel lock shoe extension so the outside edge is flush with the outside edge of the wheel lock shoe.
4. Securely tighten the two set screws to secure the wheel lock shoe extension to the wheel lock shoes.

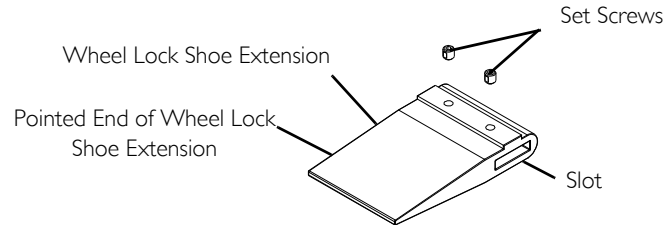

**FIGURE 11** Installing Wheel Lock Shoe Extensions

## 10 Options

### ! **IMPORTANT**

This section of the user manual provides service instructions for this product. All procedures in this section **MUST** be performed by a qualified technician/dealer.

For any service requirements beyond these procedures contact Invacare.

For a list of parts or part numbers contact your dealer/Invacare.

**DO NOT** return product without first contacting your dealer/Invacare for shipping and packing instructions.

If necessary, contact Invacare for a list of dealers.



### **DANGER**

#### **Risk of Death, Serious Injury or Damage**

Use of incorrect or improper replacement (service) parts may cause death, serious injury, or damage.

Replacement parts **MUST** match original Invacare parts.

**ALWAYS** provide the wheelchair serial number to assist in ordering the correct replacement parts.



### **WARNING**

#### **Risk of Serious Injury**

A non-qualified technician performing service procedures on this wheelchair can result in serious injury.

A qualified technician **MUST** perform all procedures in this section of the manual.



### **WARNING**

Unless otherwise noted, all service and adjustment should be performed while the wheelchair is unoccupied.

After **ANY** adjustments, repair or service and **BEFORE** use, make sure all attaching hardware is tightened securely - otherwise injury or damage may result.

## 10 OPTIONS



TOOLS: Performing procedures in this section may require the use of tools including:

Flat blade and philips head screwdrivers, standard and or metric socket set/wrenches, torque wrench, hex (Allen) keys and side cutters.

### 10.1 Installing/Cleaning Telescoping I.V. Rod/O<sub>2</sub> Holders - Non-Recliner Wheelchairs

#### Installing



#### **WARNING**

The telescoping I.V. rod/O<sub>2</sub> holder **MUST** be checked weekly to ensure it is tightly secured to the wheelchair frame. If there is any looseness whatsoever, tighten the attachment hardware securely before using.

**TELESCOPING I.V. ROD HOLDER ONLY** - Make sure the telescoping I.V. rod is tightly locked before placing I.V. medication on the rod.

The telescoping I.V. rod is designed to support I.V. medication only. **DO NOT** use it to support objects other than I.V. medication.

1. Slide telescoping I.V. rod/O<sub>2</sub> holder over the step tube of the wheelchair.



Mounting bracket of telescoping I.V. rod/O<sub>2</sub> holder should be positioned between the two axle mounting positions on wheelchair frame.

2. Secure telescoping I.V. rod/O<sub>2</sub> holder to the wheelchair frame with hex screw, spacer and locknut.
3. Telescoping I.V. Rod Holder Only - Secure the top of the telescoping I.V. rod holder to the wheelchair frame with a tie wrap.

**DETAIL "A" - I.V. ROD/O<sub>2</sub> HOLDER**

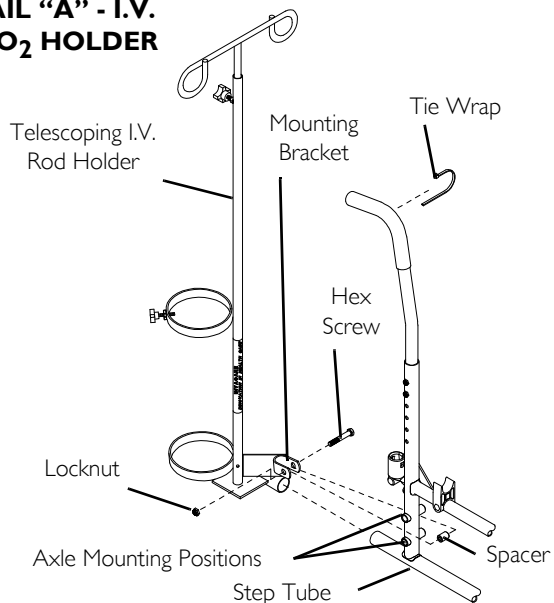

**DETAIL "B" - O<sub>2</sub> HOLDER**

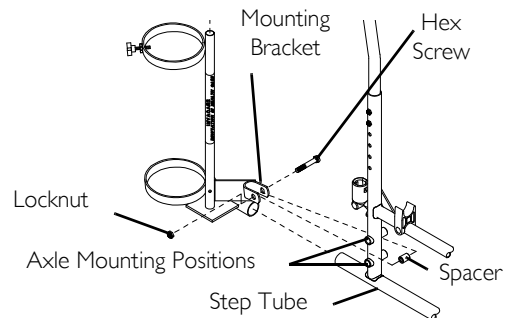

**FIGURE I** Installing/Cleaning Telescoping I.V. Rod/O<sub>2</sub> Holders - Non-Recliner Wheelchairs

## 10 OPTIONS

### 10.2 Installing Telescoping I.V. Rod - 9000 XT Recliner

#### Installing I.V. Holder

1. Remove the rear wheel from the wheelchair. Refer to [Removing/Installing Rear Wheels](#) on page 77.
2. Remove the locknut and hex screw that secure the arm socket to the wheelchair frame (Detail "A").
3. Remove the locknut that secures the back tube to the clevis bracket (Detail "B").
4. Position the top hole on the flat portion of the I.V. holder on the existing pivot screw of the clevis bracket as shown in Detail "B".
5. Reinstall locknut onto pivot screw. **DO NOT** tighten yet.
6. Thread the provided mounting screw through the lower hole on the front cylinder section of the I.V. holder, through the side frame, and into the locknut. Turn nut until snug fit is obtained. **DO NOT** tighten yet.
7. Reinstall the arm to orient front cylinder of I.V. holder. Refer to [Removing/Installing the Armrests](#) on page 42.
8. Once front cylinder is oriented for proper clearance of the armrest, securely tighten both locknuts.
9. Install the I. V. rod support tube. Refer to [Installing I.V. Rod Support Tube](#) on page 87.

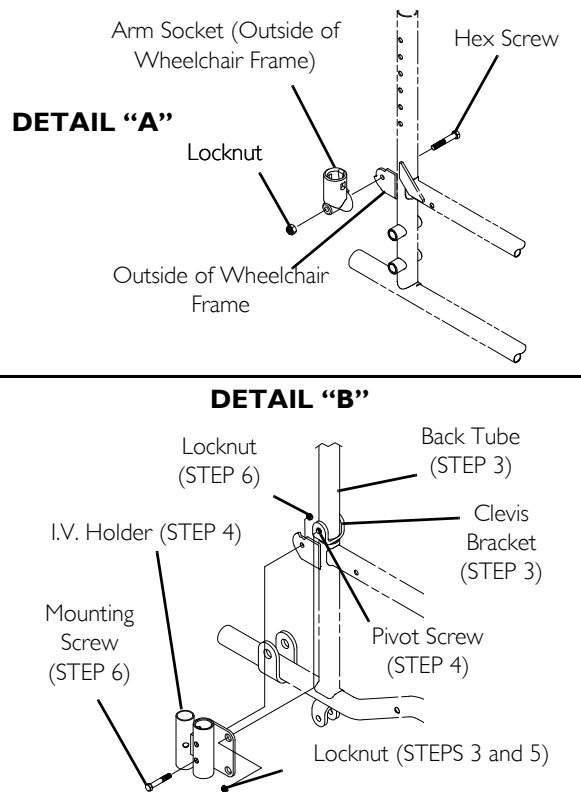

**FIGURE 2** Installing I.V. Holder

## Installing I.V. Rod Support Tube

**i** The I.V. rod holder **MUST** already be mounted to the side frame of the wheelchair.

1. Insert the I.V. rod support tube into the rear cylinder of the I.V. rod holder.

**i** When installing the I.V. rod support tube, ensure the adjustment knob is pointing out away from the wheelchair.

2. Turn the I.V. rod support tube until the holes in the I.V. rod support tube align with the holes in the rear cylinder of the I.V. rod holder.
3. Insert mounting screw through rear cylinder, large nylon washer, small nylon washer, steel washer, and into locknut. Securely tighten.

**i** The large nylon washer **MUST** be inserted into hole and pressed in so that it is flush with outside surface of rear cylinder.

4. Reinstall the rear wheel from the wheelchair. Refer to [Removing/Installing Rear Wheels](#) on page 77.
5. Adjust I.V. rod to desired height. Refer to [Adjusting I.V. Rod](#) on page 87.

## Adjusting I.V. Rod

1. Loosen adjustment knob.
2. Adjust I.V. Rod to desired height.
3. Securely tighten adjustment knob.

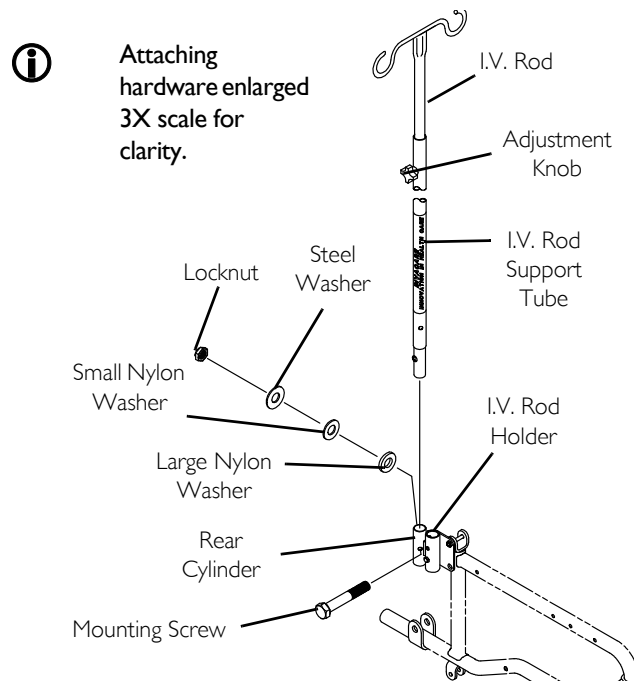

**FIGURE 3** Installing I.V. Rod Support Tube - Adjusting I.V. Rod

## 10 OPTIONS

### 10.3 Installing Crutch and Cane Carrier - Non-Recliner Wheelchairs



#### **WARNING**

Check base weekly to ensure proper placement.

When loading the crutch/cane carrier, ensure items are securely placed into the base. Also ensure that there is no interference with folding the wheelchair, the rear wheels, or the swing-back arms.

Strap **MUST** be securely fastened while carrying items.

**NEVER** insert or remove items while wheelchair is moving.

1. Slide the clamp with the base attached over the end of the step tube of the wheelchair. Ensure the base is towards the inside of the wheelchair.
2. Position the base parallel to the step tube.



#### **CAUTION**

Base should be parallel to step tube to avoid bending spokes when folding the wheelchair.

3. Securely tighten the locknut that secures the base to the step tube of the wheelchair.
4. Remove the upper back upholstery screw and washer.
5. Align the strap with the back upholstery screw mounting hole.
6. Reinstall the back upholstery screw and washer and secure the strap to the wheelchair.
7. The base cleans easily with any chrome or glass cleaner. The strap can be cleaned with mild soap and water.

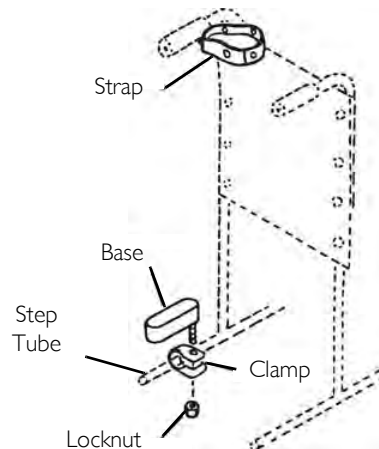

**FIGURE 4** Installing Crutch and Cane Carrier - Non-Recliner Wheelchairs



## 10.4 Installing Amputee Bracket - Non-Recliner Wheelchairs

### Super Hemi Models

1. Remove the plug button or anti-tipper from the step tube of the wheelchair frame.
2. Slide the amputee attachment over the step tube of the wheelchair.
3. Secure the amputee attachment to the wheelchair with the hex screw, spacer and locknut.
4. Reinstall the plug button or anti-tipper onto the step tube of the wheelchair frame.
5. Repeat STEPS 1-4 for the opposite side of the wheelchair.
6. Reposition the rear wheels. Refer to [Removing/Installing Rear Wheels](#) on page 57.

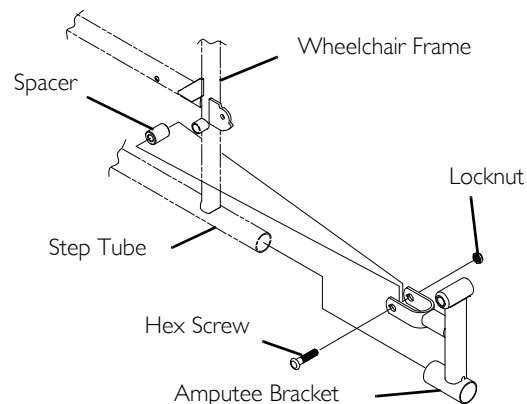

**FIGURE 5** Installing Amputee Bracket - Non-Recliner Wheelchairs

## 10 OPTIONS

### 9000SL/XT

1. Refer to the following chart or FIGURE 6 to determine the mounting position of the amputee bracket:

SEAT-TO-FLOOR	*BRACKET	AXLE SPACER POSITION (ON BRACKET)	SIDE OF WHEELCHAIR	AXLE MOUNTING POSITION (ON WHEELCHAIR)
ADULT	A	DOWN	RIGHT	TOP
ADULT	B	DOWN	LEFT	TOP
HEMI	B	UP	RIGHT	BOTTOM
HEMI	A	UP	LEFT	BOTTOM



\* "A" and "B" are stamped on the sides of the amputee bracket.

2. Install the amputee bracket on the wheelchair frame to the position determined in STEP 1.



Make sure the axle spacer is pointing towards the outside of the wheelchair.

3. Install the two hex screws and locknuts that secure the amputee bracket to the wheelchair.
4. Install the rear wheels onto the wheelchair. Refer to [Removing/Installing Rear Wheels](#) on page 57.

**Bracket "A"**

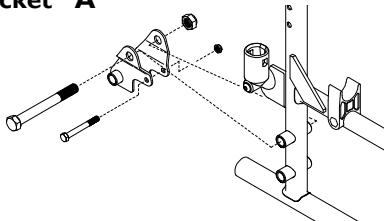

**Bracket "B"**

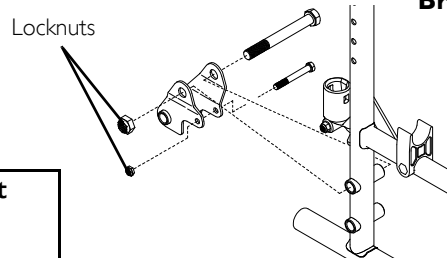

**Adult Right**

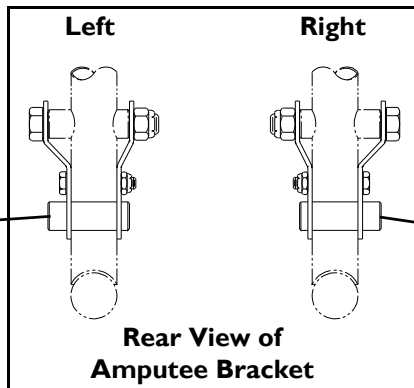

**Adult Left**

Axle Spacer Toward Outside of Wheelchair

Axle Spacer Toward Outside of Wheelchair

**Hemi Left**

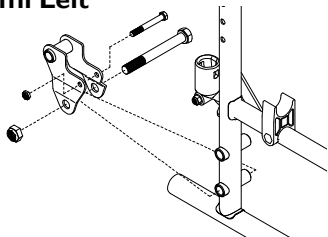

**Hemi Right**

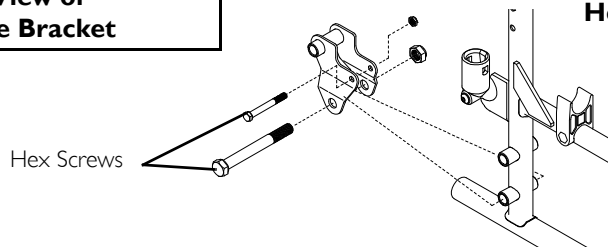

**FIGURE 6** Installing Amputee Bracket - Non-Recliner Wheelchairs - 9000SL/XT

## 10 OPTIONS

### 9000XDT

1. Refer to the following chart or FIGURE 7 to determine the mounting position of the amputee bracket:

SEAT-TO-FL OOR	*BRACKET	AXLE SPACER POSI- TION (ON BRACKET)	SIDE OF WHEEL- CHAIR	AXLE MOUNTING POSITION (ON WHEELCHAIR)
TALL	A	DOWN	RIGHT	MIDDLE
TALL	B	DOWN	LEFT	MIDDLE
ADULT	B	UP	RIGHT	BOTTOM
ADULT	A	UP	LEFT	BOTTOM
HEMI	B	UP	RIGHT	MIDDLE
HEMI	A	UP	LEFT	MIDDLE



\* "A" and "B" are stamped on the sides of the amputee bracket.

2. Install the amputee bracket on the wheelchair frame to the position determined in STEP 1.



Make sure the axle spacer is pointing towards the outside of the wheelchair.

3. Install the two hex screws and locknuts that secure the amputee bracket to the wheelchair.

4. Install the rear wheels onto the wheelchair. Refer to [Removing/Installing Rear Wheels](#) on page 57.

**Bracket "A"**

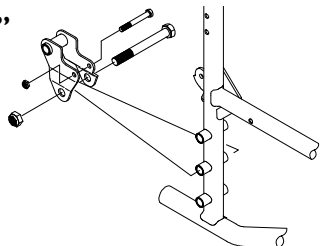

**Hemi Left**

**Hemi Right**

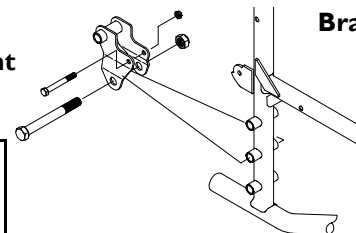

**Bracket "B"**

**Adult Left**

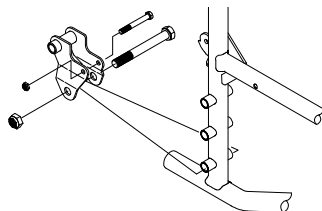

**Adult Right**

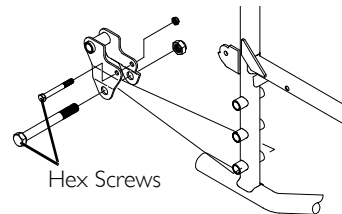

Hex Screws

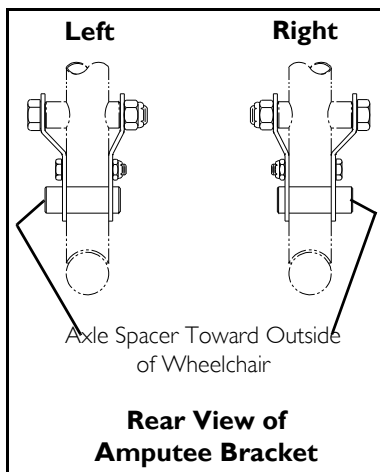

**Left**

**Right**

Axle Spacer Toward Outside of Wheelchair

**Rear View of Amputee Bracket**

**Tall Right**

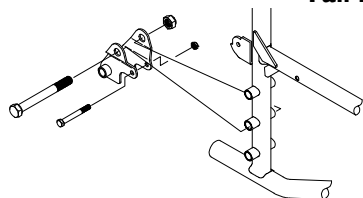

**Tall Left**

Locknuts

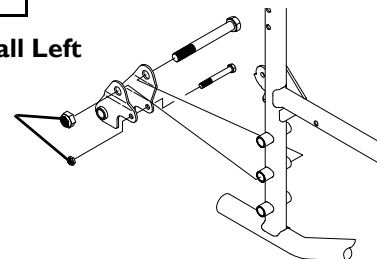

**FIGURE 7** Installing Amputee Bracket - Non-Recliner Wheelchairs - 9000XDT

---

**Notes**

---

---

**Notes**

---



**Making Life's Experiences Possible™**



***Yes, you can.®***