

JAY[®] Basic Back

IMPORTANT CONSUMER INFORMATION

NOTICE: This manual contains important instructions that must be passed on to the user of this product. Please do not remove this manual before delivery to the end user.

SUPPLIER: This manual must be given to the user of this product.

USER: Before using this product, read this entire manual and save for future reference.

WARRANTY REGISTRATION: Visit www.SunriseMedical.com to register this product.

Owner's Manual



SUNRISE MEDICAL LISTENS

Thank you for choosing a JAY Basic Back Support System. We want to hear your questions or comments about this manual, the safety and reliability of your product, and the service you receive from your Authorized Sunrise dealer. Please feel free to write or call us at the address and telephone number below:

Sunrise Medical (US) LLC

Be sure to return your warranty card, and let us know if you change your address. This will allow us to keep you up to date with information about safety, new products and options to increase your use and enjoyment of this wheelchair. If you lose your warranty card, call or write and we will gladly send you a new one.

FOR ANSWERS TO YOUR QUESTIONS

Your Authorized Dealer knows your product best, and can answer most of your questions about safety, use and maintenance. For future reference, fill in the following:

Supplier: _____

Address: _____

Telephone: _____

Serial #: _____ Date/Purchased: _____

ADDITIONAL INFORMATION YOU SHOULD KNOW

No component of this product was made with Natural Rubber Latex.



DISPOSAL AND RECYCLING INFORMATION

When this product reaches the end of its life, please take it to an approved collection or recycling point designated by your local or state government. This product is manufactured using a variety of materials. Your product should not be disposed of as ordinary household waste. You should dispose of your wheelchair properly, according to local laws and regulations. Most materials that are used in the construction of this product are fully recyclable. The separate collection and recycling of your product at the time of disposal will help conserve natural resources and ensure that it is disposed in a manner that protects the environment.

Ensure you are the legal owner of the product prior to arranging for the product disposal in accordance with the above recommendations

ENGLISH

Introduction.....3
 General Warnings.....4
 Use and Maintenance5
 Installation & Adjustment.....6
 Warranty.....7

NOTICE– READ BEFORE USE

A. CHOOSE THE RIGHT SUPPORT & SAFETY OPTIONS

This product is intended for single person use only. Selection of the type of support systems, options, and final adjustment rests solely with the user and their health care professional. Choosing the best product and set-up for safety and health depends on such things as:

1. Type of disability, strength, balance and coordination.
2. The types of hazards that must be overcome in daily use.
3. The need for options that will improve your positioning, safety and comfort (such as positioning belts, or special seating systems).

B. REVIEW THIS MANUAL OFTEN

Before using this system, you, and each person who may assist you, should read this entire manual and make sure to follow all instructions. Review the warnings often, until they are second nature to you.

C. WARNINGS

The word “**WARNING**” refers to a hazard or unsafe practice that may cause **severe injury or death** to you or to other persons. The “Warnings” are in Three main sections, as follows:

I. V– GENERAL WARNINGS

A safety checklist and a summary of risks you need to be aware of before you use this equipment.

2. VI– SAFETY WARNINGS: FALLS & TIP-OVERS

Learn about the safe use of your equipment, and how to avoid a fall or tip-over while performing daily activities.

3. VII– WARNINGS– COMPONENTS & OPTIONS

Learn about the components and options that can be selected for safety and Positioning needs. Consult your Authorized Supplier and your Health care advisor to help you choose the best set-up and options for safe use.

NOTE - Where they apply, you will also find “Warnings” in other sections of this manual. Heed all warnings in this section. If you fail to do so a fall, tip-over or loss of control may occur and cause severe injury to the rider or others.

INTRODUCTION

THE JAY BASIC BACK

The JAY Basic Back is designed to provide the important benefits of a proper back support for a wide variety of users. It is designed to provide simple, comfortable and effective support to help maximize function and increase sitting tolerance. In addition, it is lightweight, durable and easy to use.

Maximum user weight: 250 lbs. (113 kg).

GENERAL WARNINGS

A. CENTER OF GRAVITY

WARNING

Installing a back support on a wheelchair may affect the center of gravity of the wheelchair, and may cause the wheelchair to tip backwards potentially resulting in injury to the rider.

B. ANTI-TIPS

WARNING

Anti-tip tubes can help keep your chair from tipping over backward in normal conditions.

1. Sunrise recommends the use of anti-tip tubes
2. ALWAYS assess the need for anti-tips or an amputee axle adapter brackets that could be added to the wheelchair to help increase the stability of the wheelchair and seating system.

If you fail to heed these warnings damage to your chair, a fall, tip-over or loss of control may occur and cause severe injury to the rider or others.

C. PUSHING OR LIFTING

WARNING

Do not use the Back to move or push the wheelchair.

1. Do not use any part of the back to lift the wheelchair. It is intended only for Back removal.
2. Improper use of the back by pushing or pulling may cause the back to unexpectedly detach from the wheelchair.

If you fail to heed these warnings damage to your chair, a fall, tip-over or loss of control may occur and cause severe injury to the rider or others.

D. COMPATIBILITY

WARNING

The JAY Basic Back is designed to be compatible with most wheelchairs with the following exception:

1. Wheelchairs that are angle adjustable with recline or tilt, and result in a back angle greater than 60° from the vertical

Basic back use with these types of wheelchairs may cause the back to accidentally disconnect from the wheelchair. This could result in a fall or potential injury of the rider and/or caregiver.

⚠ WARNING

The owner of this equipment is responsible for making sure that it has been set up and adjusted by a Authorized Dealer under the advice of a healthcare professional. It may require periodic safety and function checks or certain in-use adjustments that can be performed by the owner, caregiver or Authorized Dealer if desired.

A. MAINTENANCE AND CLEANING

1. Proper maintenance and cleaning will improve performance and extend the useful life of your equipment.
2. Clean your equipment regularly. This will help you find loose or worn parts and make your equipment easier to use. You will need a mild detergent solution and cleaning rags.
3. If discovered, have loose, worn, bent or damaged parts replaced **before using the back support**.

B. CRITICAL SAFETY CHECKS

1. Fasteners:

Sunrise Medical recommends that all fasteners be checked for wear, such as loose bolts or broken components **Every 6 months**. Loose fasteners should be retightened according to the installation instructions.

2. Replacing components:

Contact your Authorized Dealer immediately to replace any components. Do not continue to use the system after identifying loose or broken components.

C. EASY CLEANING 3

1. Back Cover

- a. Remove the cover from backshell by detaching the Velcro®. Unzip the zipper on the bottom of the cover.
- b. Remove the foam and turn the cover inside out.
- c. Zip the cover closed to avoid snagging.
- d. Machine wash in warm water (50°C).
- e. Drip and tumble dry in on Low Heat.

NOTE – Do not dry clean covers or use industrial washers or dryers to clean covers. Do not steam autoclave. Do not bleach. Laundry care symbol definitions are shown (Fig. 1).

2. Back shell

- a. The backshell should be wiped clean with soap and water on a regular basis to prevent buildup of dirt and grime.

3. Strap and Support version

- a. Loosen straps and remove back from the wheelchair.
- b. Locate the zipper on the bottom of cover and unzip.
- c. remove foam and plastic support shell and turn the cover inside out.
- d. Zip cover closed to avoid snagging.
- e. Machine wash in warm water (50°C).
- f. Drip and tumble dry in on Low Heat.
- g. Reinsert the foam and support shell inside the cover and zip the cover closed.

NOTE - Do not dry clean covers or use industrial washers and dryers to clean cover. Do not steam autoclave. Do not bleach.

NOTE - The ABS plastic support shell is designed to be placed inside the cover to provide additional support to the back.

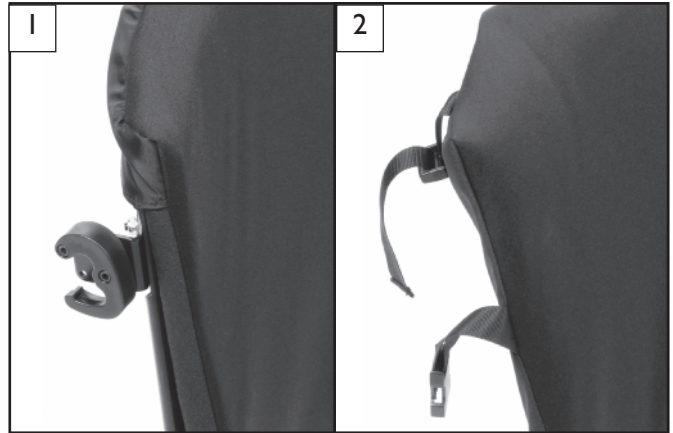

Clamp Hardware

Strap Attachment

Laundry Care Symbols		3
	Machine wash in warm water (50° C)	
	Only non-chlorine bleach, when needed	
	Drip dry	
	Do not iron	
	Do not dry clean	

A. INSTALLING THE BASIC BACK WITH STRAP ATTACHMENT 4 5

Please read the following instructions before beginning the installation. To install the Basic Back, it is best to begin without a user in the wheelchair. Once the back has been installed the user can be seated back in the wheelchair for minor adjustments. The strap attachment version of the Basic Back is mounted over, or on top of the standard sling upholstery that typically is shipped on most wheelchairs. For this version do not remove the existing sling upholstery.

1. Installation:

- a. Loosen both left and right straps (A) to the width of the back canes on your chair.
- b. Slide the straps over both back canes.
- c. Secure the back by tightening the straps. Do not overtighten the straps, check to make sure the back canes are parallel after the adjustment is made.

2. Removal:

- a. Remove the back by unsnapping the plastic buckles on each side (B)
- b. Lift the back off the chair.



B. INSTALL BASIC BACK WITH CLAMP HARDWARE

Please read the following instructions before beginning the installation. To install the Basic Back with clamp hardware, it is best to begin without a user in the wheelchair. Once the back has been installed the user can be seated back in the wheelchair for minor adjustments.

1. Prepare the chair for the Basic Back 6 7

- a. Measure the width of the Back (C) and the size of the tubing (D) before starting this installation for your chair.
- b. Remove the sling upholstery from the wheelchair according to the wheelchair manufacturer's instructions.
- c. If an aftermarket cushion is going to be used on the chair, ensure that it is placed on the wheelchair to ensure proper back height placement.



2. Locating and attaching the hardware receivers 8 9 10 11

- a. Visually determine the approximate location for the receivers on the wheelchair's back canes.
- b. The mounting hardware should be at about the same height on each backpost and parallel to the seat frame.
- c. Attach the hardware receivers by removing the screws and wrapping the hinge around the wheelchair back canes.
- d. Use the shorter screws provided to secure the clamps to 7/8" tubing, and use the longer screws provided to secure the clamps to a 1" tube.
- e. The hinge and tapered attachment must be aligned when assembling the screws. The tapered attachment should be facing upwards and the hinge should be facing forward.
- f. Place the pin in slot (E) for 7/8" tubing, and slot (F) for 1" Tubing.

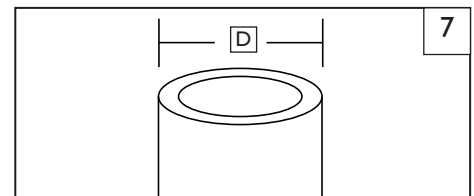
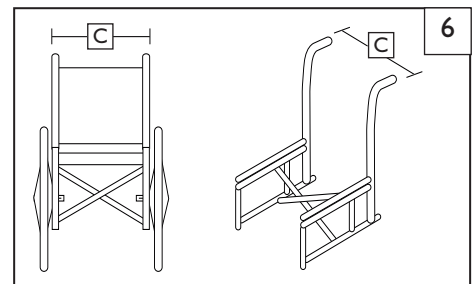

NOTE – A higher location on the back canes are generally better.

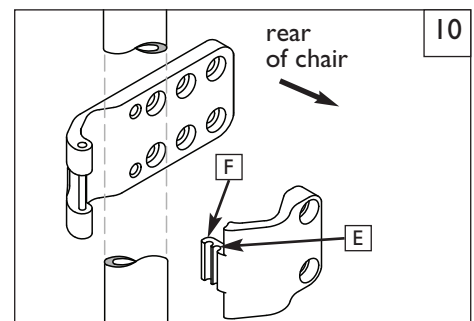
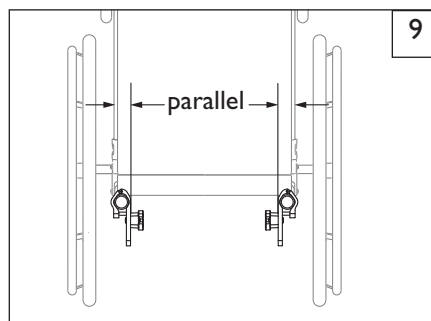
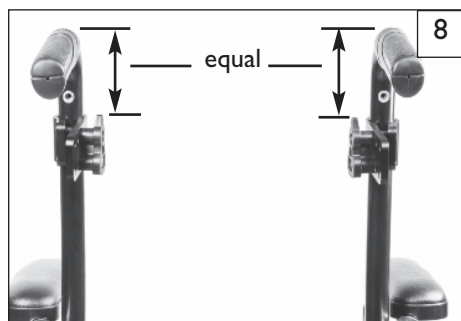

3. Attaching the back shell to the receivers 11 12 13

- a. After the receiving hardware has been attached, checked, and measured. The back can be attached to the wheelchair's back canes.
- b. Using the 4mm hex key, Loosen the clamp screws(A)
- c. Align the back shell to the mounting hardware, if the width of the shell-side hardware needs adjustment, please reference the adjustment section.
- d. Attach the back shell to the mounting hardware by raising the shell horizontally and lowering it onto mounting hardware (B). Once the shell is seated properly on the hardware, rotate the shell bottom so that the back shell is in a vertical position (Fig. 13).
- e. Test that the attachment is aligned properly by removing and re-attaching the back shell. Proper alignment of the mounting hardware and back is achieved when the back can be smoothly attached and released.
- f. If proper alignment has not been achieved, adjust the components until properly aligned.
- g. Once properly aligned, tighten the hardware receiver clamp screws (A). The recommended torque specification is 15-20 in-lbs. (1.7- 2.3 Nm).

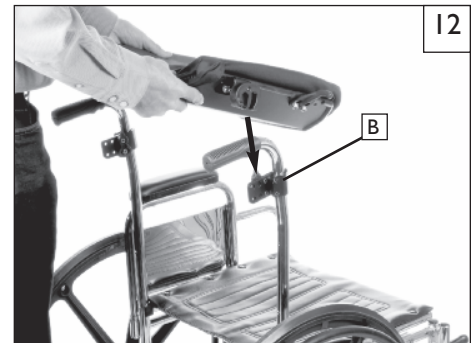
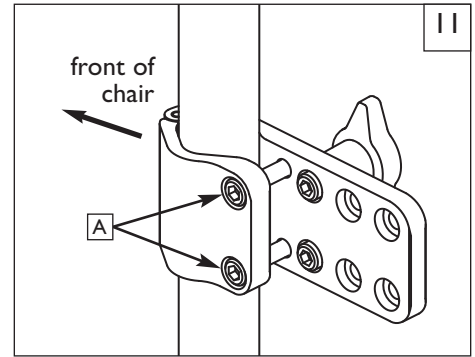

C. ADJUSTING BASIC BACK WITH CLAMP HARDWARE 14 15

Please read the following instructions before beginning the installation. To install the Basic Back with clamp hardware, it is best to begin without a user in the wheelchair. Once the back has been installed the user can be seated back in the wheelchair for minor adjustments.

I. Height adjustment

- a. Loosen the clamp screws on the chair side mounting hardware (A) and slide along the back canes until the desired height is reached. The mounting hardware should be at approximately equal heights on each back post and parallel to the seat frame.
- b. Securely tighten the chair-side screws (A). The recommended torque specification is 15 - 20 in-lbs (1.7 - 2.3 Nm).

Additional height

- c. If additional height is needed, change the position of the shell-side hardware by loosening nuts (E) and placing upper or lower hardware in optional holes (D). Securely tighten the chair-side mounting hardware. The recommended torque specification is 75 - 85 in-lbs (8.5 - 9.6 Nm). Reattach back shell to chair side mounting hardware.

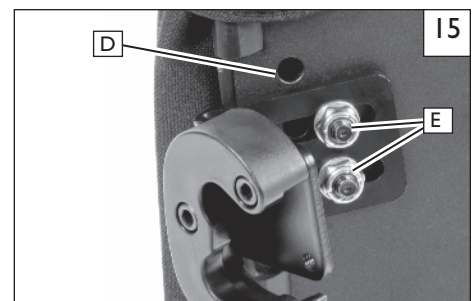
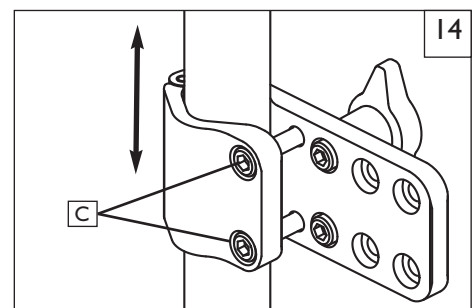

2. Angle Adjustment 16 17

The Basic Back offers up to 10 degrees of angle with limited seat depth loss.

- a. Detach the back shell from the mounting hardware.
- b. Remove the left and right socket head screws (A) on the chair side mounting hardware.
- c. Adjust the angle by moving the tapered pin (B) forward or backward in the bracket as shown in Fig. 17. Securely tighten the socket head screws. The recommended torque specification is 15 - 20 in-lbs (1.7 - 2.3 Nm).
- d. As the back angle is adjusted, also adjust the angle of the tapered pin to match (Fig. 17, inset). The recommended torque specification is 15 - 20 in-lbs (1.7 - 2.3 Nm).

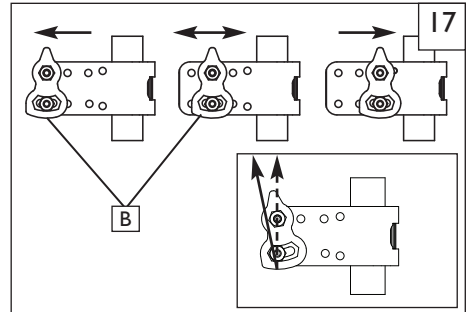
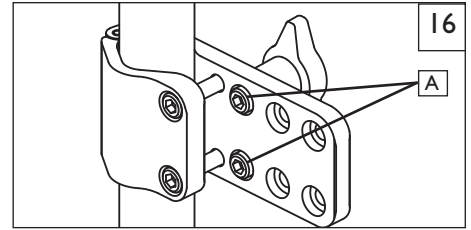

3. Width Adjustment 18 19

- a. Loosen nuts (C) using a 7/16" wrench.
- b. Slide hardware horizontally until the appropriate width is achieved. The appropriate width allows for attaching to the chair-side mounting hardware.

NOTE - Width can be adjusted +1" to allow a smaller back to be mounted on wider back canes.

- c. Secure the width nuts (C). The recommended torque specification is 75-85 in-lbs.
- d. To minimize seat depth loss, place the lower mounting hardware (D) in a lower mounting hole as seen in (Fig. 19). The recommended torque specification is 25-30 in-lbs (2.8 - 3.4 Nm).

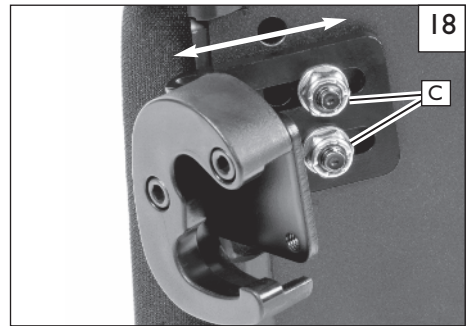

D. INSPECT

⚠ WARNING

Ensure all hardware has been properly tightened according to suggested specifications.

- a. Make sure the Back Support is locked, and the receivers are tight.
- b. Check that the Back Support can be attached smoothly and securely, by attaching and removing the assembly several times.
- c. Double check fit and comfort for the user before putting the Back Support into use.
- d. Failure to follow this check out procedure could result in injury and/or damage to your Back Support and/or components.

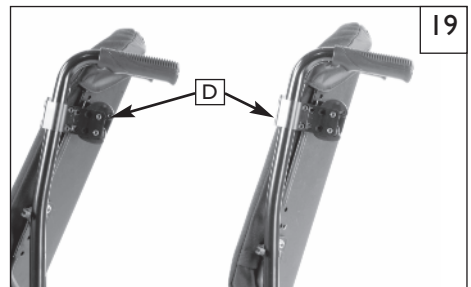

24 MONTH LIMITED WARRANTY

1. Each JAY Basic Back is carefully inspected and tested to provide peak performance. Every JAY Basic Back is guaranteed to be free from defects in materials and workmanship for a period of 24 months from the date of purchase, provided normal use. Should a defect in materials or workmanship occur within 24 months from the original date of purchase, Sunrise Medical will, at its option, repair or replace it without charge. This warranty does not apply to punctures, tears or burns, nor to the back's removable cover.

2. Claims and repairs should be processed through the nearest authorized supplier. Except for express warranties made herein, all other warranties, including implied warranties of merchantability and warranties of fitness for a particular purpose are excluded. There are not warranties which extend beyond the description on the face hereof. Remedies for breach of express warranties herein are limited to repair or replacement of the goods. In no event shall damages for breach of any warranty include any consequential damages or exceed the cost of non-conforming goods sold.

