

## User Instruction Manual

Hoyer® Elevate

To avoid injury, read user manual prior to use.

## Manuel de l'utilisateur

Hoyer® Elevate

Afin d'éviter tout accident, veuillez lire attentivement la notice avant utilisation.

## Manual de Instrucciones

Hoyer® Elevate

Para evitar posibles daños, lea previamente el manual de usuario.

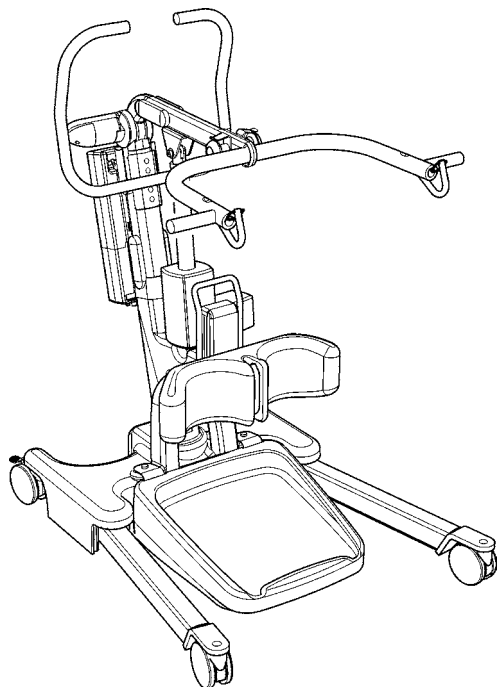

## Contents

1. Hoyer Elevate Patient Lift.....	3
2. Introduction: About Your Lift.....	4
3. Assembly and Commissioning Instructions.....	5
4. Sling Guide.....	9
5. Lifting with the Hoyer Elevate.....	11
6. Safety Precautions .....	12
7. Standard Control Box & Handset.....	14
8. Smart Monitor and Handset .....	15
9. Operating Instructions .....	19
10. Charging Instructions.....	21
11. Digital Weigh Scale .....	22
12. Maintenance Schedule & Daily Check List .....	25
13. Technical Specifications .....	27
14. Warranty .....	30

# 1. The Hoyer Elevate Patient Lift

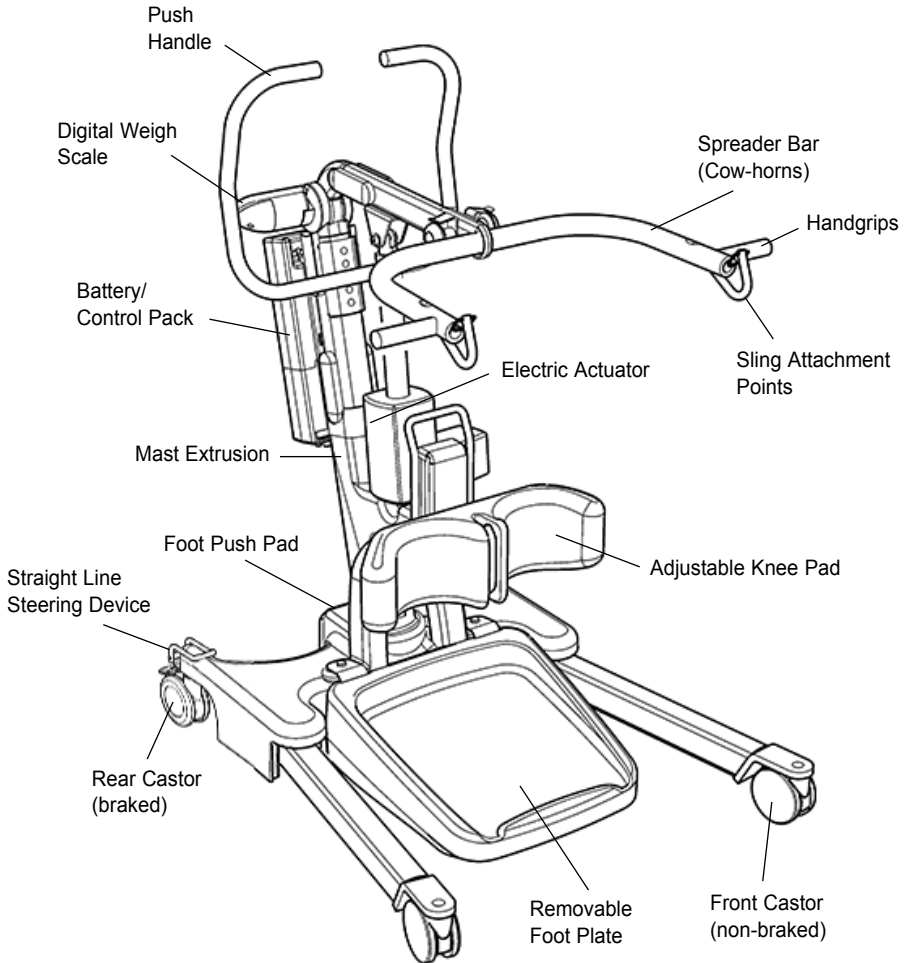

## 2. Introduction: About Your Lift

Each Elevate lift is fully assembled, load tested and certified before being packed/shipped.

The packing consists of a strong, purpose built carton to ensure the safe arrival of the lift. A number of documents are supplied in a wallet, and packed with each lift and should be kept safely for future reference:

- TEST CERTIFICATE
- USER MANUAL

The TEST CERTIFICATE is an important document and will be required for your insurance records. It is valid for six months and after it has expired the lift should be inspected and serviced per the maintenance schedule.

Your authorised dealer can carry out servicing and periodic testing for those countries where this is a requirement (Europe). Please ensure your lift is included in their maintenance schedule. If you are at all unsure what your local market servicing requirements are, please check with your dealer, a local government agency and/or Joerns Healthcare.

### Statement of Intended Use

The intended use of this lifting device is for the safe lifting and transfer of an individual from one resting surface to another (such as a bed to a wheelchair). Joerns Healthcare recommends that the transfer of a patient is fully risk assessed and conducted safely over a short distance only.

The Hoyer Elevate is suitable for patients in the SITTING position only who have a degree of weight-bearing ability but require assistance to stand. By removing the foot tray, the Hoyer Elevate patient lift can also be used as a walking aid following a careful risk assessment.

The Hoyer Elevate is designed to support and promote safe patient handling and transfer for both the patient and carer. As an option, it incorporates a fully calibrated digital weigh-scale for patient weight monitoring.

The Hoyer Elevate stand aid is designed to be used in conjunction with the Hoyer range of slings. The examples of slings suitable for use with this device are listed as follows:

- Hoyer Standing Sling
- Hoyer Transport Sling

### Expected Service Life

Hoyer Professional lifts are designed and tested for a minimum service life of ten (10) years, subject to the use and maintenance procedures stated in this manual. Use, other than in accordance with these instructions, may compromise service life.

## 3. Assembly and Commissioning Instructions

### Carton Contents

Place the carton in a clear working area and open carefully. The carton contains:

- HOYER ELEVATE LIFT
- CHARGING CORD
- WALLET CONTAINING DOCUMENTS
- DESK TOP CHARGER/STAND
- HAND CONTROL
- SPIRIT LEVELLING DEVICE
- BATTERY PACK

### **▲ WARNING**

The Hoyer Elevate is heavy and will need to be lifted with care. You may need assistance to lift the Hoyer Elevate from the carton.

### Assembly

Remove the Elevate from the carton and place on the floor.

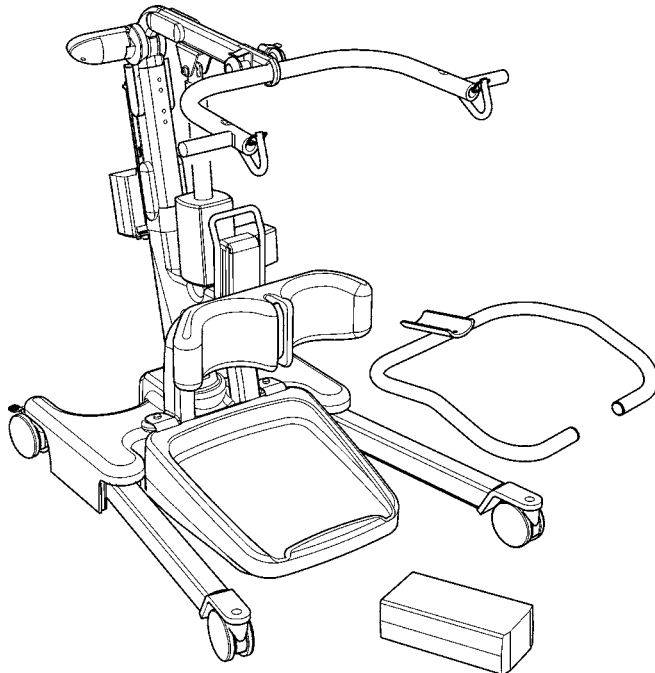

1. Tighten the mast assembly with the mast-locking device, which is located at the front of the chassis.

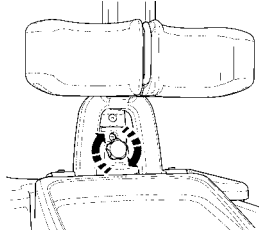

2. Turn the locking knob until hand tight.

3. Line the handle assembly up to the mast, and attach using the fasteners provided (these can be found in the mast). The wrench needed to attach the handle is kept in the user instruction wallet for safe keeping.

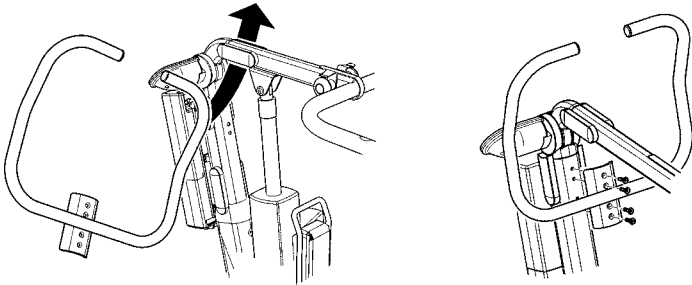

**CAUTION:** Ensure that the handle is secure and in place prior to using lift.

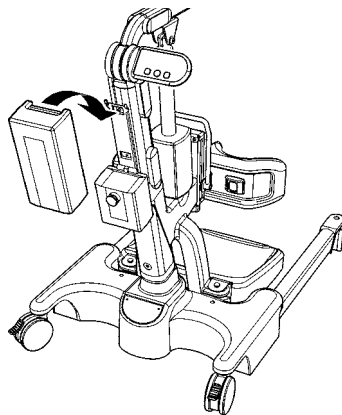

4. Fit power pack to the lift and make sure the latch holding the pack in place is fully engaged. "Click" in place.

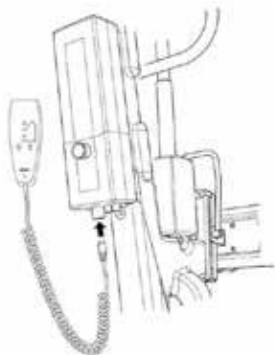

5. Fit the hand control to the lift as shown. Once complete, check the hand control is functioning correctly by referring to page 8.

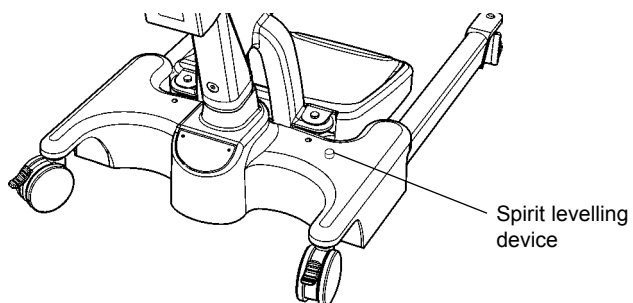

6. A self adhesive spirit levelling device is supplied as a reference tool for use when maximum weighing accuracy is required. For maximum accuracy when weighing, centre the spirit level prior to weighing the patient.

## Disassembly

The lift should not be disassembled unless for service, repair or transport if necessary. Therefore follow the assembly instructions in [reverse sequence](#).

## Always check the following before operation

- The mast is fully locked into position.

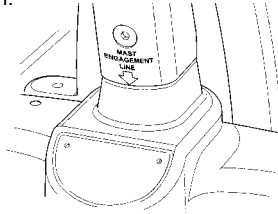

- The red emergency stop button, located on the rear of the control box, is in the OFF (out) position.

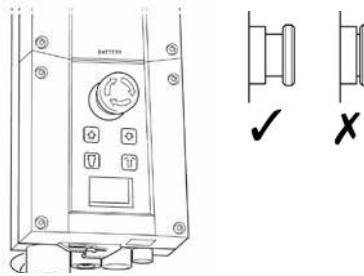

- The legs of the lift open and close satisfactorily (This is done via the hand control).



- Push the up and down buttons on the hand control and confirm the boom rises and lowers.

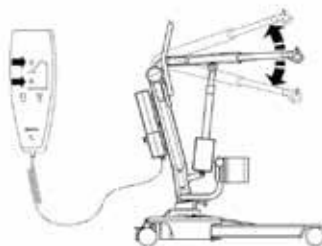



## 4. Sling Guide

The Hoyer Elevate is suitable for patients in the SITTING position. The slings suitable for this device are listed as follows:

- Hoyer Transport sling
- Hoyer Standing sling

### User Guide For Standard Slings

The Transport and Standing sling is an easy fit sling, suitable for standing and supporting. It is not a general purpose sling and patients must be assessed for suitability by a qualified person.

#### Transport Sling

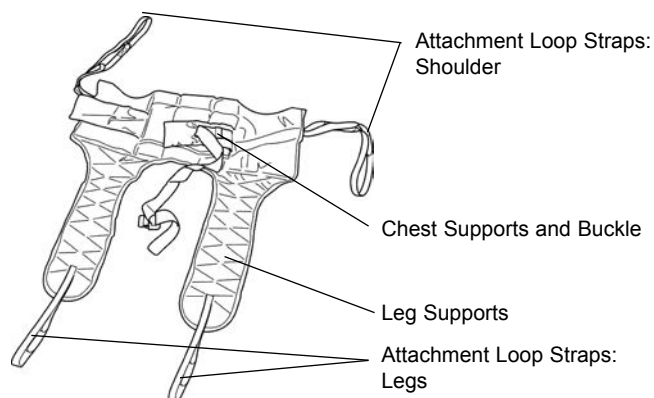

Feed the sling down the back of the patient leaving the top of the commode aperture at the base of the spine. Check the roll part of the sling is square across the patient's back.

Attach the support strap around the chest of the patient. This strap need not be tight. It is there to hold the sling in position whilst attaching the loops to the Standaid. It may be left off altogether if preferred. Ensure patient's arms are on the outside of the sling.

Raise the patient's leg and feed the leg strap under and up between the legs. Ensure the sling is not twisted or creased under the thigh. Repeat this procedure for the other leg. Attach the loops on the roll parts of the sling to the white hooks at the end of the hand grips.

Without crossing the loops on the leg straps, attach to left and right black knobs on the lifting fork. You would normally use the middle of the three loops. The patient is now ready to be raised from the seat. Once clear of the seat, the patient will be more comfortable if lowered back in to the sitting position.

## Standing Sling

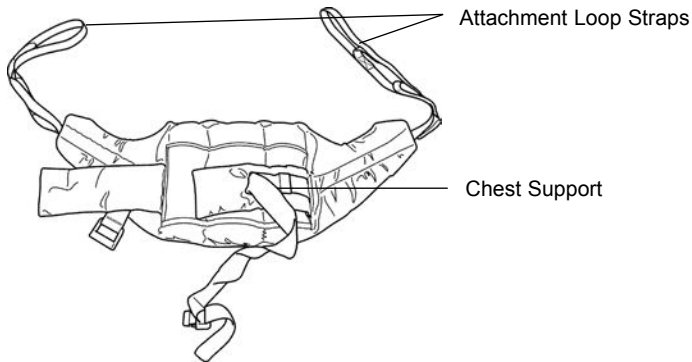

Place the sling down behind patient's back between base of shoulder blades and bottom of rib cage. Attach the support straps around the front of the patient. This strap need not be tight. It is there to hold the sling in position whilst attaching the sling to the Standaid. It may be left off altogether if preferred. Ensure that the patient's arms are outside the sling.

**NOTE:** For detailed fitting instructions, please refer to the user guide supplied with each sling.

### **⚠ WARNING**

Joerns Healthcare recommends that slings be checked regularly and particularly before use for signs of fraying or damage. **DO NOT** use slings that are worn or damaged.

### **⚠ WARNING**

**HOYER RECOMMENDS THE USE OF GENUINE HOYER PARTS.** Hoyer slings and lifters are not designed to be interchangeable with other manufacturer's products. Using other manufacturer's products on Hoyer products is potentially unsafe and could result in serious injury to patient and/or caregiver.

### **⚠ WARNING**

Refer to maximum weight capacity of lift. Sling capacity is limited by the maximum capacity of the lift.

## 5. Lifting with the Hoyer Elevate

Position the Elevate so that the patient's feet fit in the foot tray and knees rest against the knee pad. Attach the loops of the sling to the hooks at the end of the Elevate hand grips. The patient's hands should be placed on the handgrips (see Fig. A or C). Then push the UP button on the hand control to raise the patient to the standing position (see Fig. B or D).

**Note:** For lifts sold outside of the US, dedicated hand grips are not incorporated. Patients are therefore encouraged to use the cow-horn if additional support is required.

### Standing Sling

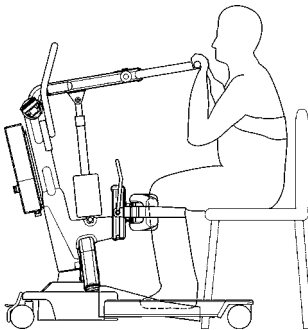

Fig. A

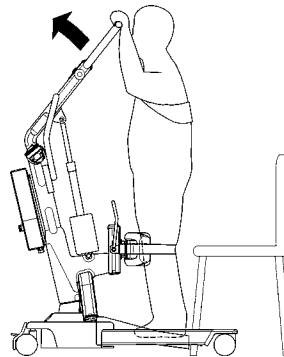

Fig. B

### Transport Sling

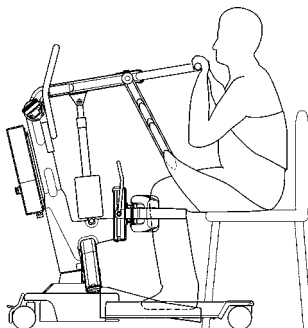

Fig. C

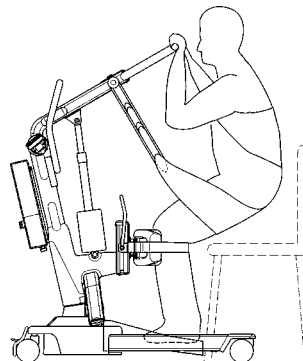

Fig. D

### **⚠ WARNING**

If using the Hoyer Elevate for gait training, the foot tray should be removed and a thorough risk assessment carried out to ascertain suitability prior to lifting.

## 6. Safety Precautions

Please read and follow the safety precautions listed below. The operation and use of Hoyer patient lifts is simple and straightforward. Following these few basic safety precautions will make lifting operations easy and trouble free.

### **READ AND UNDERSTAND THE USER INSTRUCTION MANUAL BEFORE USING THE HOYER ELEVATE LIFT**

**WARNING:** Important safety information for hazards that might cause serious injury.

**CAUTION:** Information for preventing damage to the product.

**NOTE:** Information to which you should pay special attention.

### **WARNING**

- **DO NOT lift a patient unless you are trained and competent to do so.**
- **ALWAYS carry out the DAILY CHECK LIST located towards the end of the manual before using the lift.**
- **DO NOT exceed the safe working load of the lift.**
- **ALWAYS plan your lifting operations before commencing.**
- **ALWAYS familiarize yourself with the operating control and safety features of a lift before lifting a patient.**
- **DO NOT use a sling unless it is recommended for use with the lift.**
- **ALWAYS check the sling is suitable for the particular patient and is of the correct size and capacity.**
- **NEVER use a sling, which is frayed or damaged.**
- **ALWAYS fit the sling according to the instructions provided (user instructions).**
- **ALWAYS check the safe working load of the lift is suitable for the weight of the patient.**
- **ALWAYS carry out lifting operations according to the instructions in the user manual.**
- **NEVER disconnect or bypass a control or safety feature because it seems easier to operate the lift.**
- **ALWAYS lock the wheels when lifting from the floor.**
- **DO NOT attempt to manoeuvre the lift by pushing on the mast, boom or patient.**
- **ALWAYS manoeuvre the lift with the handle provided. A foot push pad is also provided.**
- **DO NOT push a loaded lift at speeds, which exceed a slow walking pace (2.6 ft/sec).**
- **DO NOT push the lift over uneven or rough ground. Particularly if loaded.**
- **DO NOT attempt to push/pull a loaded lift over a floor obstruction.**

- **NEVER** force an operating/safety control. All controls are easy to use and do not require excessive force.
- **DO NOT** park a loaded lift on **ANY** sloping surface.
- **DO NOT** use electric lifts in a shower.
- **DO NOT** use or store a lift in a wet or corrosive environment such as shower, bath or pool locations.
- **DO NOT** charge batteries in a bathroom or shower room.
- **DO NOT** place or store batteries under direct sunlight or near a heat source.
- **YOUR** lift is for patient lifting. **DO NOT** use it, or allow it to be used, for any other purpose.
- **DO NOT** bump the lift down steps, loaded or unloaded.
- **DO NOT** attempt to negotiate a loaded lift on a slope, which exceeds 1:12 (approximately 5 degrees)
- **DO NOT** attempt to negotiate a slope without a second helper being present.
- **DO NOT** use a loaded lift on thick pile carpet.
- **NEVER** operate the lift with loose or missing parts or fasteners.
- **INSPECT** all precautionary labels on the lift. Order and replace all labels that cannot be easily read.

## 7. Standard Control Box & Handset

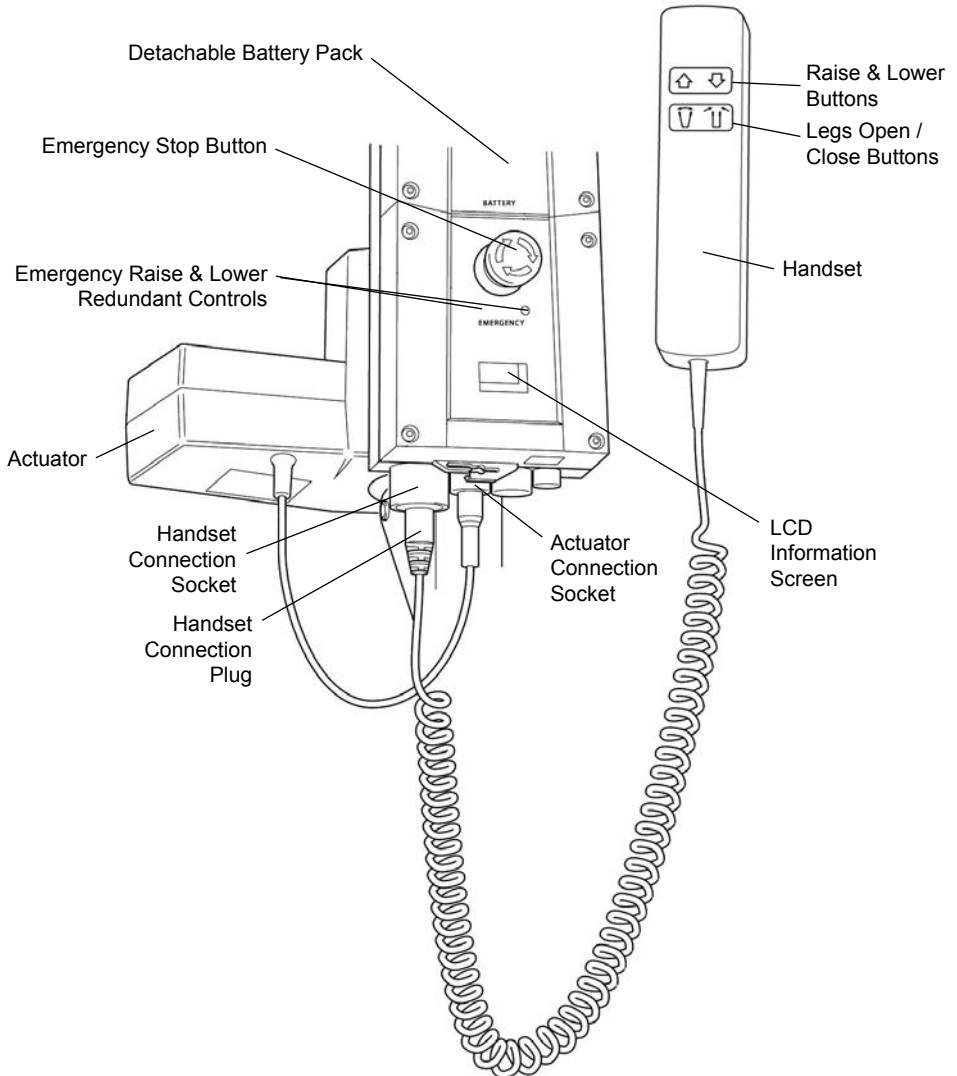



## Intended Use

The Hoyer Smart Monitor is a control system for Hoyer lifts. The Smart Monitor stores useful servicing information about the lift that can be recalled when required. This servicing information includes:

- Number of patient lift cycles
- Total work done by actuator
- Number of lift overloads (attempted lifts above the safe working load)
- Number of days since last service interval

The Hoyer Smart Monitor contains a microprocessor inside making it possible to read out service data via the on-board LCD screen.

## Features

- Data collection in the control box with data display via LCD screen
- Work counter
- Intelligent cycle counter
- Service indicator
- Service interval indicator
- Overload information
- 3 step battery indicator

## Benefits





- Improved safety for both patient and carer
- Accurate service data available at the touch of a button
- Optimised product life time
- Ease of maintenance for engineers and service technicians



## LCD Display Screen

The Hoyer Smart Monitor has the option to read out information via the LCD display screen. It is possible to read out total lifting cycles, total work done, overloads and number of days since last service, which can be used to quickly and easily evaluate the condition of the lift actuator.

This information is accessed by a ½ second press on the 'UP' button on the User handset or redundant 'UP' button on the Smart Monitor.

	12034	— Total Lifting Cycles
	1257000	— Total Work Done (Amps * Seconds)
	7	— Number of Overloads
	90/360	— Number of Days (since last service) / Number of Days (between services)

## Service & Usage Information



When it is time for a service, the service symbol will appear on the display. In addition, when the user handset is activated, the Smart Monitor will give an audible signal giving notice to users that a PM check is recommended (see recommended maintenance schedule later in this manual).

The service symbol will be displayed each time the raise or lower keys are depressed on the user handset.

To reset the service interval to one year, depress the leg open and leg close keys simultaneously for five seconds.



If the lift stops because of an overload (an attempt to lift more than the safe working load) the overload symbol will appear on the LCD display and the lift will cease. Lower the boom and remove excess weight.

### WARNING

If the LCD display screen on your Smart Monitor has recorded an overload, Joerns Healthcare recommend that **ALL** routine daily checks are carried out on the lift prior to further use (for a list of daily checks, please refer to your lift user manual). Joerns Healthcare also recommend that you contact your authorised Hoyer service provider for additional guidance.

## On-Board Redundant Controls

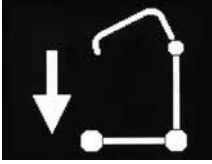

On-board redundant controls enable the lift to be raised or lowered in the event of an emergency.

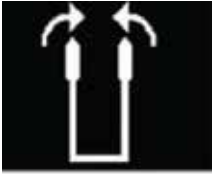

If your lift incorporates powered leg positioning, there are redundant controls to both open and close the legs.

## Battery Information

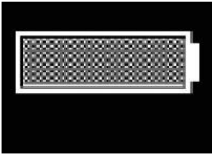

The display showing full battery means that the battery is fully charged and the lift is ready for use.

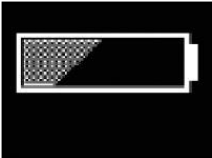

The display showing a half empty battery indicates that it is time to charge the battery.

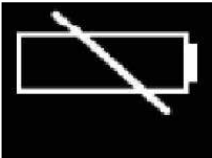

The empty battery symbol showing on the display indicates that the battery has no capacity left and should be placed on charge immediately.

### **⚠ WARNING**

To avoid possible permanent damage to the battery, the battery should be placed on charge as soon as the display indicates the half empty battery symbol.

## 9. Operating Instructions

### 1. Leg adjustment

The legs on the Hoyer Elevate are electrically adjustable for width. The legs can be opened to enable access around armchairs or wheelchairs. For transferring and negotiating narrow doorways and passages the lift legs should be in the closed position.

Electric leg adjustment - is achieved by pressing the appropriate buttons on the handcontrol. The legs will be locked whenever the handcontrol switch is released.

### 2. Castors and Braking

The lift has two braked castors which can be applied for parking. When lifting, the castors should be left free and un-braked. The lift will then be able to move to the centre of gravity of the lift. If the brakes are applied it is the patient that will swing to the centre of gravity and this may prove disconcerting and uncomfortable.

### 3. Raising & Lowering The Boom

A powerful electric actuator that is controlled by a simple hand control unit achieves the movement of the boom. The hand control has two buttons with directional arrows UP and DOWN ↑↓. The actuator stops automatically at its limit of travel in both directions. The hand control plugs into a socket at the base of the control box.

### 4. Emergency Stop

The red Emergency Stop Button is located on the front of the control box and is activated by pressing in. This will cut all power to the lift and only be reset by twisting the button anti-clockwise and releasing.

### 5. Redundant controls

All Hoyer lifts are fitted with raise and lower buttons on the control box. These are located underneath the emergency stop button and can be used to lower/raise the patient should the hand control fail.

### 6. Mechanical Emergency Down

In the case of a complete electrical failure the electrical actuator is fitted with mechanical lowering device (RED BOSS). This will only operate when the lift is under load. The device must be pulled upwards to activate, and a slow decent will commence.

**Note:** The MINIMUM load required to manually lower the hoist using the mechanical emergency down function is 30 kg. This is an emergency device and not intended for repetitive use.

### 7. Batteries

A LOW VOLTAGE ALARM protects the batteries from deep discharge. This will sound when the batteries need recharging and the hand control is being operated. It will not sound independently of the hand control being operated. **DO NOT IGNORE THIS WARNING ALARM.** Complete the lifting operation and place the battery on charge (see charging instructions). The battery charge level is displayed by the indicator on the control box.

## CAUTION

**The battery, charger, hand control, control box and actuator should not be opened by unauthorised personnel. (Contact your distributor for warranty and repairs).**

## 8. Slings

The Hoyer Elevate is suitable for patients in the SITTING, position. The slings suitable for this device are listed as follows:

- Hoyer Transport sling
- Hoyer Standing sling

## 9. Knee pad adjustment

The Elevate has an adjustable kneepad. It is recommended for safety reasons that adjustment is carried out by holding the top of the adjustment handle. The range of travel is approx 7 inches. Adjustment is achieved by following two easy steps. STEP 1 pull handle towards you, STEP 2 either push handle downwards or pull handle upwards to select the kneepad position. Once the ideal position is found release handle and the kneepad will automatically lock into position.

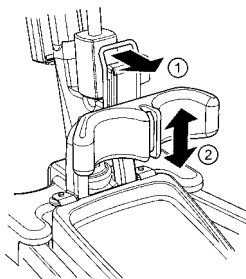

## 10. Removable footplate

The Elevate has a removable footplate. To remove the footplate, move to the front of the product, and lift the footplate upwards from the middle of the assembly (see Fig. E). Additionally you can also remove the footplate cover to aid in cleaning and disinfecting of the footplate area. This is achieved by removing the footplate and unclipping the cover from the back of the footplate (see Fig. F).

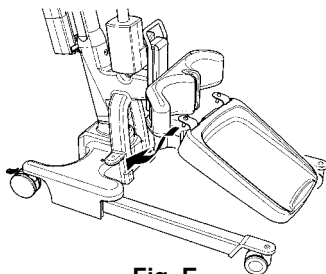

Fig. E

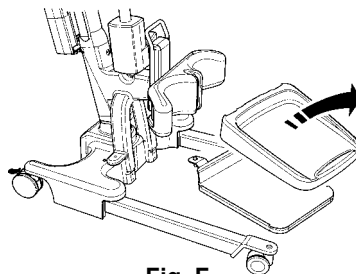

Fig. F

**NOTE:** Be careful when lifting the footplate from its low-seated position.

## **⚠ WARNING**

If using the Hoyer Elevate for gait training, the foot tray should be removed and a thorough risk assessment carried out to ascertain suitability prior to lifting.

## 10. Charging Instructions

When the power pack needs charging it is removed from the lift and fitted to an off board charging unit.

1. Remove the power pack from the lift. The pack is retained by a simple latch at the top of the power pack. Lift the latch and the power pack will be released.
2. Fit the power pack to the charging unit. The location and latching of the power pack to the charger is the same system as used on the lift.
3. Plug the charger mains plug into a suitable mains outlet and switch the mains supply ON.
4. Charging is automatic and will fully charge the batteries over a period of four (4) hours.

**Note:** Even if the charger is left plugged in for extended periods it will not allow the batteries to overcharge.

- a) Green Light - Indicates main power is on.
- b) Yellow Light - Indicates battery is charging.
- c) Battery will be fully charged when yellow light goes off.

**Note:** It is recommended that the battery be charged immediately upon receipt.

5. To return the lift to service, unplug the charger and remove the power pack from the charger. Fit the power pack to the lift and make sure the latch holding the pack in place is fully engaged. "Click" in place. The charging of Hoyer electric lifts is simple and straightforward, but it is important to follow the charging instructions closely. Please pay particular attention to the following points, they will help you avoid problems with discharged batteries.

### **WARNING**

- **The battery, charger, hand control and control box are NOT to be opened by unauthorised personnel. (Contact your distributor for warranty and repairs).**
- **DO NOT touch battery/charger terminals.**
- **KEEP the batteries fully charged. Place the battery on charge whenever it is not in use. If it is more convenient to do so, place on charge every night. The charger will not allow the batteries to overcharge.**
- **NEVER run the batteries completely flat. As soon as the audible warning sounds, complete the lifting operation in hand and place on charge.**
- **To avoid possible permanent damage to the battery, the battery should be placed on charge as soon as the display indicates the half empty battery symbol.**
- **NEVER store the battery for long periods without regular charging throughout the storage period.**
- **NEVER leave the battery pack connected with the charger unit unplugged.**
- **DO NOT leave the charger plugged in with no battery connected.**
- **NEVER disconnect the charger plug by pulling on the cable.**
- **BE CAREFUL not to trip over the charge lead.**
- **DO NOT charge batteries in a bathroom or shower room.**

## 11. Digital Weigh Scale

The Hoyer Elevate has an integrated digital weigh scale.

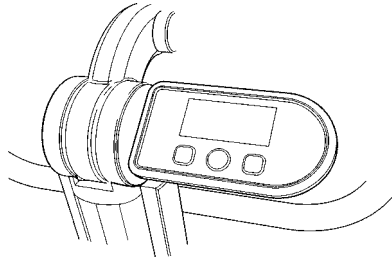

### About your Scale

The Hoyer Digital Scale is a technologically advanced, microprocessor controlled, digital weighing device. It features a large, easy to read, Liquid Crystal Display (LCD) that shows the patient's weight.

The controls are simple and straightforward to use. The Hoyer Digital Scale is powered by a 9-volt disposable battery, which will provide approx. 3000 weighing operations before replacement will be necessary.

The Hoyer Digital Scale is suitable for patients in the SITTING position.

### Operating Instructions

The Hoyer scale has been designed and certified to weigh up to **200kg or 440lbs in 0.2 increments.**

**NOTE:** For customers or users in North America, your scale will measure in either Lbs or Kgs. For all other countries outside NA, your scale will weigh in Kgs.

**To weigh a patient follow the instructions below:**

1. Assemble the sling to the cow horn and press the ON/ZERO pad. The display will show 0.0 and the word HOLD will appear in the lower left hand corner. This step prepares the scale for weighing. The sling can now be removed from the cow horn or cradle and placed around the patient.
2. Place the sling around the patient ensuring the patient's feet are in the foot tray. Attach the sling to cow horns and raise the patient so that they are in the standing position. They must not be touching anything such as a chair or bed since this will cause an error in weighing.
3. The scale has been designed to turn itself off after 60 seconds to conserve battery life. To restart the scale, push the ON/ZERO pad (once only). The display will show the start up screen and then show the patient's weight. When the HOLD sign appears, the weight can be recorded.

**NOTE: To restart the scale, be sure to push the ON/ZERO. If the scale starts and the pad is pushed again, the scale may go to zero (0.0) and the patient's weight may be lost. This may require the reweighing of the patient.**

4. The RECALL feature is designed to retain in the memory the last stable weight over 10 kg/22lbs. To access this weight, the scale must be on. Press the RECALL pad. The display will flash between "RECL" and the retained weight.

## Maintenance

It is recommended that twice yearly inspections of the connections on the scale be scheduled and performed to assure trouble free operation. Look for wear or any irregularities that may contribute to scale failure.

If any wear or irregularity is seen **DO NOT USE THE LIFT** and contact Joerns Healthcare to access the assembly.

## Technical Specifications

- **Electronics.** Microprocessor controlled.
- **Power.** 9-volt alkaline battery PP3.
- **Battery life.** Exceeds 70 hours continuous operation.
- **Display.** LCD (liquid crystal display) 63 X 18 mm Characters 15 mm high.
- **Weighing units.** Kilograms (kgs) or (Lbs and kgs North America only)
- **Load cell.** Rated at 300 kgs/660 lbs.

### **WARNING**

**Do not exceed the safe working load of the lift.**

A 9-volt battery powers the Hoyer Electronic Digital Scale. A new battery should provide approximately 3000 readings before needing replacement. When it needs to be replaced, a “B” will appear on the display.

## To Replace Battery

1. Push black pad on bottom of unit to left.
2. Battery holder will slide out.
3. Remove old battery and replace with a new one.
4. Push holder back into scale.

## Operation Features

- All functions are accessible to the user without opening the case.
- Starting or zeroing the scale is done through a single touchpad located on the front of the case.
- Stable readings are achieved through digital averaging. The HOLD message is activated when weight fluctuations decrease to a predetermined range. The scale becomes active again when that range is exceeded. The held weight is stored in a non-volatile memory for later recall if required.
- Display turns off after 60 seconds of inactivity to conserve battery life.
- Recall of the last held weight is available via a touchpad on the front of the case. This allows a reading of the last patient's weight, after the patient has been removed from the scale.
- Battery change is made easy with external access to the battery holder.

## Maintenance, Inspection and Test

Joerns Healthcare recommends that a thorough inspection and test of all Hoyer lifts and lifting accessories, slings etc. is carried out every six months. Joerns Healthcare recommends maintenance, inspection and certified testing, is only carried out by competent and authorised service dealers.

**NOTE:** These recommendations are in compliance with the requirements of 1998 No2307 Health and Safety: The Lifting Operations and Lifting Equipment Regulations 1998. This is a UK regulation.

**Outside the UK please check your local requirements.**

### Important Note (Europe Requirement Only)

The Hoyer Weigh scale is a class 3 compliant weighing device and conforms to the NAWI Directive 90/384/EEC and has been certified by the National Weights and Measures Laboratory.

**NOTE:** Scale is calibrated prior to shipment.



## 12. Maintenance Schedule & Daily Check List

All Hoyer products are designed for minimum maintenance, however some safety checks and procedures are required. A schedule of DAILY tasks are detailed below. Daily checks and a six monthly service, inspection and test will ensure a lift is kept in optimum safe working condition. A list of spare parts is available upon request.

The **LOAD TEST** and certification should only be carried out by qualified personnel or an authorised service agent / dealer.

**DAILY CHECK LIST:** Joerns Healthcare strongly recommends the following checks be carried out on a daily basis and before using lift.

- MAKE sure the lift moves freely and all 4 castors touch the floor.
- EXAMINE the spreader bar (cow horns) is firmly attached to the boom.
- EXAMINE the sling hooks and attachment clips on the cow horn and boom for excessive wear.
- MAKE sure the legs open and close correctly.
- OPERATE the hand control to confirm the boom raises and lowers satisfactorily.
- CHECK the operation of the emergency stop button.
- EXAMINE slings for fraying or other damage. **DO NOT** use any sling if damaged.
- CONFIRM the lift is not giving a low battery alarm when the hand control is operated. If the alarm sounds, **DO NOT** use and place on charge immediately.

### Maintenance, Inspection and Test

Joerns Healthcare recommend a thorough inspection and test of the Hoyer Elevate lift and lifting accessories, slings, scales etc is carried out on a regular basis. Inspection frequency varies from country to country so you must check with your dealer or local government agency as appropriate regarding how often an inspection is required. The examination and test should be conducted according to the recommendations and procedures below. Joerns Healthcare recommends maintenance, inspection and certified testing is carried out by authorised service agent / dealers only.

### Cleaning

All Hoyer lifts will when necessary require cleaning. Hoyer lifts can be cleaned with warm water or a disinfectant cleaning fluid.

**NOTE:** Harsh chemicals may dull or remove the paint/finish from the lift.

### **WARNING**

**DO NOT** spray or submerge the lift in any liquid.

**\*THESE CHECKS SHOULD INCLUDE:**

✓ = Recommended

	Initially	Before Use	Service Intervals
1. <b>BOOM:</b> Check the attachment of the boom to the mast. Make sure there is only minimal side movement of the boom and the boom is free to rotate on the boom bearing.	✓	✓	✓
2. <b>SLING ATTACHMENT POINTS:</b> Examine the sling hooks and attachment clips on the spreader bar and boom for excessive wear.	✓	✓	✓
3. <b>MAST:</b> Check the operation of the mast-locking device. Make sure the mast fully engages into the socket.	✓	✓	✓
4. <b>ACTUATOR:</b> The actuator should require no maintenance other than checking for correct operation and listening for unusual noise.	✓		✓
5. <b>KNEE PAD:</b> Check knee pad adjuster is fastened securely.	✓	✓	✓
6. <b>SMART MONITOR:</b> Check the function of the emergency stop button. Inspect the hand control socket for correct fitting. Check functioning of the hand control. Check the redundant controls and confirm they operate as intended. The MINIMUM load required to manually lower the hoist using the emergency lower function is 30 kg.	✓	✓	✓
7. <b>BATTERIES:</b> The batteries are housed in the power pack and should not require maintenance other than the regular charging as detailed in the charging instructions. Check that the connections remain clean.			✓
8. <b>LEG ADJUSTMENT:</b> Check the legs operate in both full extensions (inward/outward).	✓		✓
9. <b>CASTORS:</b> Check all castors for firm attachment to the legs. Check for free rotation of the castor and the wheels.	✓	✓	✓
10. <b>CLEANING:</b> Using a damp cloth, wipe clean with ordinary soap and water and/or any hard surface disinfectant. Harsh chemical cleaners or abrasives should be avoided as these may damage the surface finish of the lift. Avoid wetting any of the electrical parts.		✓	✓
11. <b>BASE AND WHEELS:</b> Ensure base is even and level (all four wheels are on the floor).	✓	✓	✓
12. <b>SLINGS:</b> Check for wear and fraying.	✓	✓	✓
13. <b>LUBRICATION:</b> Lubricate pivot joints with a silicone based oil, including mast and boom connections, pedal assembly, spreader bar joint (only if required).			✓
14. <b>HAND SET:</b> Ensure plugged fully into controller.	✓	✓	
15. <b>QUICK RELEASE PIN:</b> Ensure the pin is securely fitted before lifting.	✓	✓	



## Electrical Specifications

BATTERIES.....	24 volt Rechargeable sealed lead acid type
BATTERY CAPACITY .....	3.2 Ampere hours
CHARGER RATED INPUT .....	100 - 240 V AC// 24 VDC 50/60 Hz
CHARGER RATED OUTPUT .....	29.5 VDC, Max. 19 W

### Electric Shock Protection

CHARGER.....	CLASS II
LIFT .....	INTERNAL POWER SOURCE

### Degree of Shock Protection

CHARGER.....	TYPE B
LIFT .....	TYPE B

## Environmental Conditions

Outside this environment functionality and safety may be compromised.

### Operating:

Temperature .....	5°C to 35°C
Relative humidity .....	20% to 90% @ 30°C - not condensing
Atmospheric pressure .....	700 to 1060 hPa

### Storage:

Temperature .....	5°C to +50°C
Relative humidity .....	20% to 90% @ 30°C - not condensing
Atmospheric pressure .....	700 to 1060 hPa

### IP RATINGS

Control Box .....	IPX4
Actuator .....	IPX4
Off Board Charger .....	IPX5
Battery .....	IPX5
Handset .....	IPX5

### DUTY CYCLES

Actuator .....	10% (2 min./18 min.)
Charger .....	Approx. 4 hrs.

### ACOUSTICS

A-Weighted sound power level .....	55.6 dB (A)
------------------------------------	-------------

## Key Symbols

The following symbols are used on the charger, control unit and battery:



Type B equipment, as per EN 60601-1



Class 2 equipment



The disposal of the charging and control unit should not be mixed with general household waste

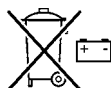

The disposal of batteries should not be mixed with general household waste.



The disposal of electronics should not be mixed with general household waste



For indoor use



ATTENTION, consult accompanying documents.

## 14. Warranty

This warranty covers HoyerPro lifts only. Lifts not covered under this warranty include, but are not limited to Advance-H, HML400, HPL600WB, HPL600WBSC, HPL402, C-HLA (and variations).

HoyerPro lifts are guaranteed for a period of two years from the date of delivery against defects in materials and workmanship under normal use and service. This warranty includes all mechanical and electrical components.

Aluminium structural components and mechanical components on lifts are covered under warranty for a period of five (5) years from the date of delivery.

Damage caused by use in unsuitable environmental conditions or failure to maintain the product in accordance with user and service instructions is not covered. Any alteration, modification or repair unless performed by or authorized in writing by Joerns Healthcare will void this warranty.

### Parts

HoyerPro lifts contain various parts that wear from normal use. These parts, such as DC batteries and casters are not covered under the two-year warranty but are covered for 90 days after date of delivery.

Joerns Healthcare's obligation under this warranty is limited to supplying replacement parts, servicing or replacing, at its option, any product which is found by Joerns Healthcare to be defective.

Warranty replacement parts are covered by the terms of this warranty until the product's original warranty period expires.

When requested by Joerns Healthcare, parts must be returned for inspection at the customer's expense. Credit will be issued only after inspection.

### Service

Most service requests handled by the facility Maintenance Department with assistance from the Joerns Healthcare Product Service Department.

Most parts requested can be shipped next day air at the customer's expense.

Should a technician be required, one will be provided by Joerns Healthcare, at our discretion. Only the Joerns Healthcare Product Service Department can dispatch authorized technicians.

This warranty is extended to the original purchaser of the equipment.