



ASSEMBLY



OPERATION



COMFORT

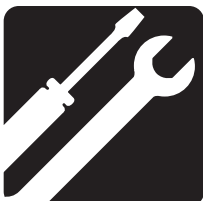

MAINTENANCE

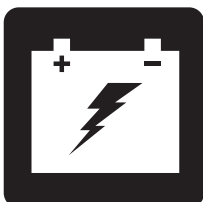

BATTERY  
CHARGING

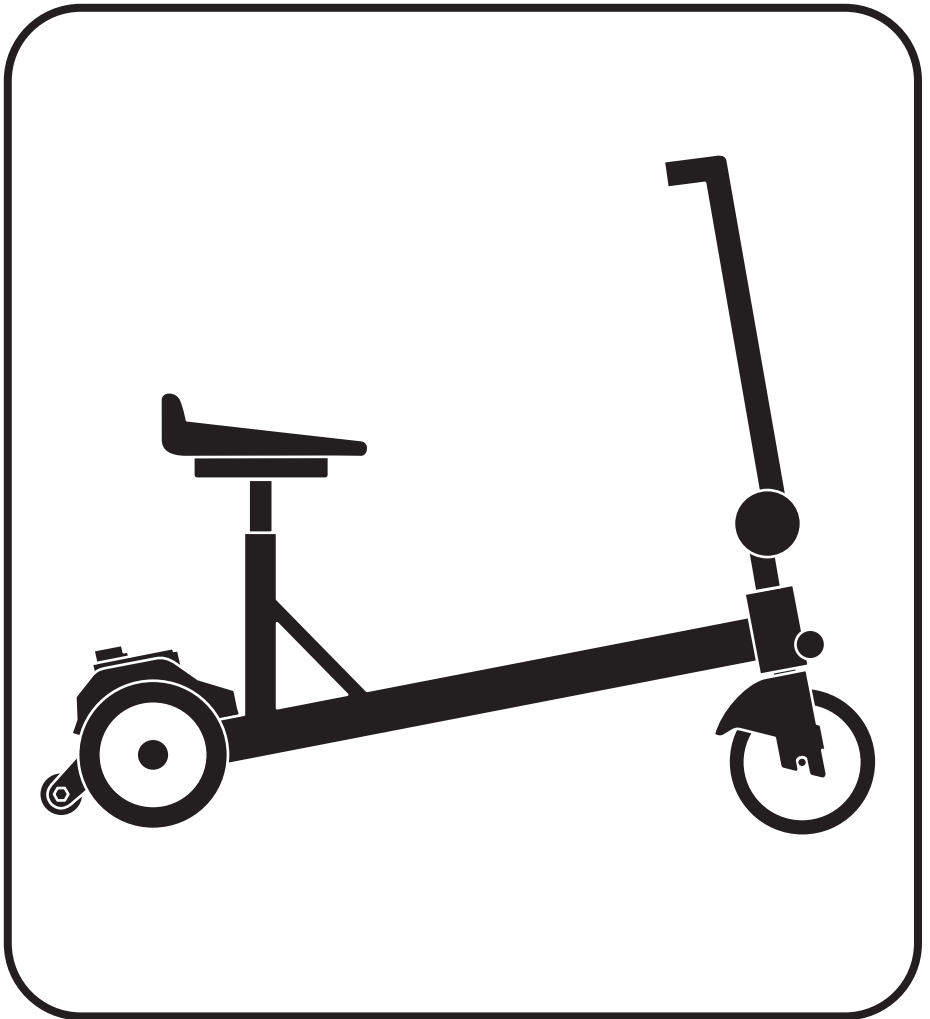

# iRIDE™ (S25)

## OWNER'S MANUAL

---

# SAFETY GUIDELINES



**WARNING!** An authorized Dealer or qualified technician must perform the initial setup of this scooter and must perform all of the procedures in this manual.

The symbols below are used throughout this owner's manual and on the scooter to identify warnings and important information. It is very important for you to read them and understand them completely.



**WARNING!** Indicates a potentially hazardous condition/situation. Failure to follow designated procedures can cause either personal injury, component damage, or malfunction. On the product, this icon is represented as a black symbol on a yellow triangle with a black border.



**MANDATORY!** These actions should be performed as specified. Failure to perform mandatory actions can cause personal injury and/or equipment damage. On the product, this icon is represented as a white symbol on a blue dot with a white border.



**PROHIBITED!** These actions are prohibited. These actions should not be performed at any time or in any circumstances. Performing a prohibited action can cause personal injury and/or equipment damage. On the product, this icon is represented as a black symbol with a red circle and red slash.



**CALIFORNIA PROPOSITION 65 WARNING!** This product may contain substances which are known to the state of California to cause cancer and birth defects or other reproductive harm.

## INTENDED USE

The intended use of this Pride Mobility Products® Scooter is to provide mobility to persons with full use of their upper and lower extremities and who are able to support themselves in an upright position. This product is primarily for indoor use and the outdoor capabilities are limited to hard, flat, and even surfaces such as concrete, black top, and other similar surfaces. While we understand that the scooter's outdoor capabilities are limited, when driving near uneven obstacles, follow the safety guidelines outlined within the safety section of this manual.

This product is not a medical device and is not intended to assist, treat, diagnose or alleviate any medical condition or disability.

*NOTE: This owner's manual is compiled from the latest specifications and product information available at the time of publication. We reserve the right to make changes as they become necessary. Any changes to our products may cause slight variations between the illustrations and explanations in this manual and the product you have purchased. The latest/current version of this manual is available on our website.*

*NOTE: This product is compliant with WEEE, RoHS, and REACH directives and requirements.*

*NOTE: This product meets IPX4 classification (IEC 60529).*

*NOTE: The scooter and its components are not made with natural rubber latex. Consult with the manufacturer regarding any after-market accessories.*



# CONTENTS

<b>SAFETY GUIDELINES</b> .....	<b>2</b>
<b>INTRODUCTION</b> .....	<b>4</b>
<b>I. SAFETY</b> .....	<b>5</b>
<b>II. YOUR SCOOTER</b> .....	<b>21</b>
<b>III. BATTERIES AND CHARGING</b> .....	<b>24</b>
<b>IV. OPERATION</b> .....	<b>28</b>
<b>V. COMFORT ADJUSTMENTS</b> .....	<b>30</b>
<b>VI. DISASSEMBLY AND ASSEMBLY</b> .....	<b>31</b>
<b>VII. BASIC TROUBLESHOOTING</b> .....	<b>32</b>
<b>VIII. CARE AND MAINTENANCE</b> .....	<b>33</b>

## Language Usage

This owner's manual is intended for distribution in all English-speaking countries where our scooters are sold. We have chosen to compose this manual using language and spellings common to the USA. Since we recognize that not all English-speaking countries use the same words or spellings, please refer to the following chart for some common word variations that may be encountered throughout this manual.

USA	Variation	USA	Variation
meter	metre	elevator	lift
backward(s)	rearward(s)	center	centre
authorized	authorised	curb	kerb
counterclockwise	anticlockwise	trunk	boot
tire	tyre	wrench	spanner
cord	lead	color	colour
pocketbook	handbag	labor	labour

# INTRODUCTION

## SAFETY

The scooter you have purchased combines state-of-the-art components with **safety**, comfort, and styling in mind. We are confident that these design features will provide you with the conveniences you expect during your daily activities. Once you understand how to **safely** operate and care for your scooter, it should give you years of trouble free operation and service.

**Read and follow** all instructions, warnings, and notes in this manual before attempting to operate your scooter for the first time. You must also read all instructions, warnings, and notes contained in any supplemental instructional booklets before initial operation. Your **safety** depends upon you, as well as your Dealer, caretaker, or healthcare professional in using good judgment.

If there is any information in this manual which you do not understand, or if you require additional assistance for setup or operation, please contact your authorized Dealer. **Failure to follow the instructions in this manual and those located on your scooter can lead to personal injury and/or damage to the scooter, including voiding the warranty.**

## PURCHASER'S AGREEMENT

By accepting delivery of this product, you promise that you will not change, alter, or modify this product or remove or render inoperable or unsafe any guards, shields, or other safety features of this product; fail, refuse, or neglect to install any retrofit kits from time to time provided to enhance or preserve the safe use of this product.

## SHIPPING AND DELIVERY

Before using your scooter, make sure your delivery is complete as some components may be individually packaged. If you do not receive a complete delivery, please contact your authorized Dealer immediately. Where damage has occurred during transport, either to the packaging or content, please contact the delivery company responsible.

***NOTE: If you ever lose or misplace your copy of this manual, contact us and we will be glad to send you a new one immediately.***

# I. SAFETY

## GENERAL



**MANDATORY! Do not operate your new scooter for the first time without completely reading and understanding this owner's manual.**

If you discover a problem, contact your authorized Dealer for assistance. Please refer to the Contact Information insert in your Owner's Package.

## PRODUCT SAFETY SYMBOLS

The symbols below are used on the scooter to identify warnings, mandatory actions, and prohibited actions. It is very important for you to read and understand them completely.



**Read and follow the information in this owner's manual.**



**Scooter information label**



**Fully charge batteries before operating.**

**Switch battery power button to the off position on an unattended scooter.**



or



**Does not meet ISO 7176-19 standards for occupied transport in a motor vehicle. When traveling in a motor vehicle, do not sit in your scooter.**



**Manufactured in**



**Indicates a potentially hazardous situation which, if not avoided, could result in death or severe injury. Property damage may also result.**



**Indicates electrical shock hazard.**



**EMI/RFI – This product has been tested and passed at an immunity level of 3 V/m.**



**Indicates that explosive conditions exist.**

# I. SAFETY



**Corrosive chemicals contained in batteries.**



**Indicates hot surface. Avoid contact.**



**Indicates a mandatory action that should be performed as specified in order to avoid a hazardous condition/situation. Failure to perform mandatory actions can lead to personal injury and/or equipment damage.**



**Indicates maximum weight capacity. Stay within the specified weight capacity of your product.**



**Battery has been tested and complies with United Nations Transport Regulations standard UN38.3. Check with airline prior to travel.**

DOT 49 CFR 175.106(V17)



**Protect from heat sources.**



**Your product must be disposed of according to applicable local and national statutory regulations. Contact your local waste disposal agency or authorized Dealer for information on proper disposal of packaging, metal frame components, plastic components, electronics, batteries, neoprene, silicone, and polyurethane materials.**



**Contact your local recycling center or authorized Dealer for information on proper recycling of product components.**



**Indicates component is for indoor use only.**



**Keep area clean.**



**Keep area dry.**



**Indicates a prohibited action that should not be performed at any time or in any circumstances. Performing a prohibited action can cause personal injury and/or equipment damage.**



**Keep tools and other metal objects away from battery terminals. Contact with tools can cause electric shock.**

# I. SAFETY



**Do not allow unsupervised children to play near the scooter while the batteries are charging.**



**Do not connect an extension cord to the AC/DC converter or the battery charger.**



**Do not use a cell phone, walkie-talkie, laptop, or other radio transmitter while operating.**



**Indicates flammable material. Do not expose to heat sources such as open flame or sparks. Do not transport batteries with flammable or combustible items.**



**Do not tamper with, modify, or attempt to repair the mobility device. Contact your authorized Dealer for service or repair.**



**Avoid exposure to rain, snow, ice, salt, or standing water whenever possible. Maintain and store in a clean and dry condition.**



**Do not remove anti-tip wheels.**



**Keep your hands, clothing and all other objects away from the tires when driving. Do not allow any personal belongings or objects to drag behind the scooter when driving. Be aware that loose fitting clothing or other objects can become caught in drive wheels and/or they may become entangled in the running gear.**

# I. SAFETY

## General Safety Guidelines

Your scooter is a state-of-the-art, life-enhancement device designed to increase mobility. We provide an extensive variety of products to best fit the individual needs of the scooter user. Please be aware that the final selection and purchasing decision regarding the type of scooter to be used is the responsibility of the scooter user, who is capable of making such a decision.

**WARNING! Do not operate your scooter for the first time without completely reading and understanding all information available with your scooter, including but not limited to safety labeling, owner's manuals, and supplemental instructional booklets.**

**WARNING! The iRIDE is not intended for use by persons who cannot support themselves in an upright position.**



**WARNING! Prior to operating your scooter, familiarize yourself with the location and use of controls, including the tiller for steering, the throttle for accelerating, and the handbrake for stopping. During operation, unless gripping the handbrake, keep both hands on the tiller at all times to assure safe operation of the scooter. Failure to both release the throttle and engage the handbrake when stopping the scooter can result in collision with people or objects which may result in property damage, personal injury or death.**

**WARNING! The iRide is intended for operation on flat, even surfaces whether indoors or outdoors. Examples of "indoors" typically include, but are not limited to, linoleum, hardwood, tile, non-pile and low-pile carpeting. Examples of "outdoors" typically include, but are not limited to, concrete, asphalt, macadam, and certain refined brick configurations. Do not operate your scooter on or near uneven surfaces such as stairs, drop-offs, ledges, grass, gravel, sand, mulch, dirt, mud or deteriorated concrete, asphalt or other uneven surfaces. Failure to heed this warning may result in damage to the product or cause instability and tipping resulting in personal injury or death.**

The following are precautions, tips, and other safety considerations intended to help you become accustomed to operating your scooter safely. While we recognize that scooter users will frequently develop skills to manage daily activities that may differ from those illustrated in this manual, it is imperative that all safety guidelines in this manual be followed to ensure user safety. Failure to follow the safety notices in this and other manufacturer-supplied manuals and those located on your scooter can lead to personal injury and/or damage to the scooter, and may result in voiding the product warranty.

## Modifications

We have designed and engineered your scooter to provide maximum mobility and utility. Under no circumstances should you modify, add, remove, or disable any feature, part, or function of your scooter.

**WARNING! Do not modify your scooter in any way not authorized by your Dealer. Do not use accessories if they have not been tested or approved for scooter. Approved accessories must be installed by your authorized Dealer or a qualified service technician.**



**WARNING! The addition of accessories to the scooter may change the overall weight, size, and/or center of gravity of your scooter. It is important to take note of these changes to avoid damage to the scooter and surrounding property.**



**WARNING! Do not add any side body anti-tip wheels or other side body stability enhancements. Doing so may diminish ground clearance and promote instability when the user comes in contact with any raised surface. We acknowledge certain high weight capacity products have side body anti-tip wheels. These are intended to enhance product stability during transfer on and off of the scooter and do not enhance the dynamic stability of the scooter.**

The center of gravity of your seat was factory set to a position that meets the needs of the demographic majority of users.



**WARNING! Do not change your seating configuration without first contacting your authorized Dealer. Only your authorized Dealer or a trained service technician should make adjustments to the seat.**



**WARNING! Do not use seats on your scooter that have not been tested or approved for your scooter. Using unapproved seats could affect the center of gravity of your scooter, resulting in a tip or a fall.**



# I. SAFETY

You should not modify the electrical system in any way not authorized by the scooter manufacturer.

**WARNING! Do not connect any aftermarket or auxiliary devices to the scooter electrical system or use the scooter batteries to power any aftermarket or auxiliary devices unless you are using an adapter that has been tested and approved by the scooter manufacturer. Do not cut or splice any original equipment wires, cables, or leads for the purpose of adding aftermarket or auxiliary devices to the scooter as this may result in damage to the electrical system and batteries.**



**WARNING! Do not pull on electrical leads directly to detach them from the scooter. Always grasp the connector itself when disconnecting the lead to prevent wire damage.**



**WARNING! Ensure that the off-board charger power cord connectors are clean and dry before plugging the connectors into either the off-board charger socket or the electrical socket. Service the charger power cord regularly. Failure to do so may result in damage to the electrical system and/or personal injury.**

**WARNING! In the event of a loss of power to the scooter, transfer to a safe position, seeking assistance if needed. Contact your authorized Dealer immediately to report the incident.**

## Weight Limitations

Your scooter is rated for a maximum weight capacity. Please refer to the product specifications table for this limit. Keep in mind that the maximum weight capacity includes the combined weight of the user and any accessories mounted to the scooter. Stay within the specified weight capacity of your scooter. Exceeding the weight capacity voids your warranty. We will not be held responsible for injuries and/or property damage resulting from failure to observe weight limitations.



**WARNING! We recommend that you do not use the scooter as a seat during weight-training activities or as a weight-training apparatus. Such use can lead to undue stress and fatigue on scooter components, and can also affect center of gravity, resulting in a tip or a fall. We will not be held responsible for injuries and/or property damage resulting from use of the scooter in weight-training activities or as a weight-training apparatus.**



**WARNING! Do not carry passengers on your scooter. Carrying passengers on your scooter may affect the center of gravity, resulting in a tip or a fall. We will not be held responsible for injuries and/or property damage caused by carrying passengers on the scooter.**



**WARNING! Do not use the scooter to haul, move, or tow other vehicles, including lawn mowers, ATV equipment, or other mobility devices. Your scooter was not designed with such use in mind and any damage or injury incurred from such use is not the responsibility of the scooter manufacturer.**



Figure 1. Weight Limitations

# I. SAFETY

## Incline Information

More and more buildings have ramps with specified degrees of inclination, designed for easy and safe access. Some ramps may have turning switchbacks (180-degree turns) that require you to have good cornering skills on your scooter.

- Proceed with extreme caution as you approach the downgrade of a ramp or other incline.
- Take wide swings with your scooter's front wheels around any tight corners. If you do that, the scooter's rear wheels will follow a wide arc, not cut the corner short, and not bump into or get hung up on any railing corners.
- When driving down a ramp, keep the scooter's speed adjustment set to the slowest speed setting to ensure a safely controlled descent.
- Avoid sudden stops and starts.

When climbing an incline, try to keep your scooter moving. If you must stop, start up again slowly, and then accelerate cautiously. When driving down an incline, set your scooter to the slowest speed setting and drive in the forward direction only. If your scooter starts to move down the incline faster than you anticipated or desired, allow it to come to a complete stop by releasing the twist throttle and engage the brake levers slightly until you reach your desired speed.



**WARNING! When on any sort of an incline or decline, ensure the parking brake is engaged.**



**WARNING! When climbing an incline, do not zigzag or drive at an angle up the face of the incline. Drive your scooter straight up the incline. This greatly reduces the possibility of a tip or a fall. Always exercise extreme caution when negotiating an incline.**



**WARNING! You should not travel up or down potentially hazardous inclines, including but not limited to areas covered with snow, ice, cut grass, or wet leaves.**

**WARNING! Never travel down an incline or ramp backward. Doing so may cause the scooter to tip. Always exercise extreme caution when negotiating an incline.**

Handicap public-access ramps are not subject to government regulation in all countries, and therefore do not necessarily share the same standard degree of slope. Other inclines may be natural or, if man-made, not designed specifically for scooters. Your scooter's ability to travel up inclines is affected by your weight, travel speed, angle of approach to the incline, and your scooter setup, including seat configuration. Therefore, we recommend that the maximum slope of an incline you attempt to safely ascend or descend on your scooter does not exceed the maximum allowable incline listed in the product specifications. Refer to the following table for standard degree of slope guidelines that are available for regions as noted. See **figure 2**.

# I. SAFETY

Geographic Location	Minimum Safe Slope Requirement
USA (Americans with Disabilities Act–ADA)	ADA requires 5° (8.7%)
Europe (CE mark) Class A	3° (5.2%)
Europe (CE mark) Class B	6° (10.5%)
Europe (CE mark) Class C	10° (17.6%)

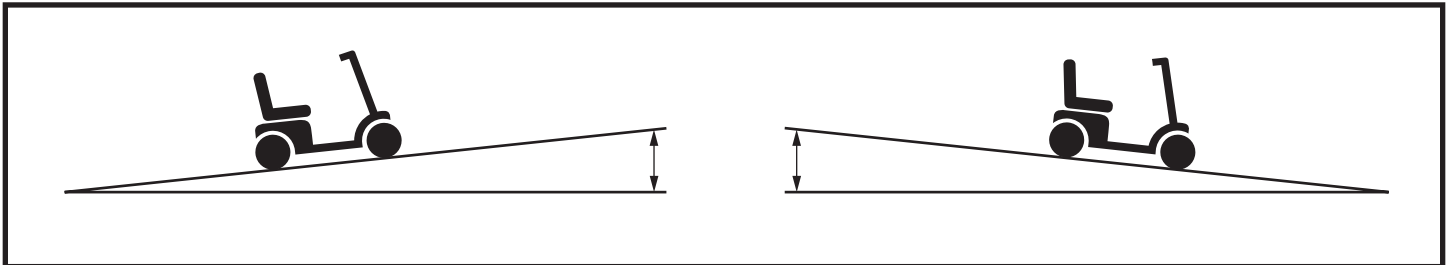

Figure 2. Maximum Allowable Incline Angle (Ascending and Descending)

**WARNING!** Your scooter has been tested in accordance with certain standards. You should not exceed the performance specifications of your scooter as noted in the product specifications.



**WARNING!** Any attempt to climb or descend a slope steeper than that specifically listed in your scooter product specifications may put your scooter in an unstable position and cause it to tip.

**WARNING!** Don't carry anything or add any accessory that will adversely affect the center of gravity or exceed the weight capacity of the scooter. Doing so could affect the center of gravity of the scooter, resulting in a tip over.

When you approach an incline, it is best to lean forward. This shifts the center of gravity of you and your scooter toward the front of the scooter for improved stability. See figures 3 and 4.



Figure 3. Normal Driving Position



Figure 4. Increased Stability Driving Position

# I. SAFETY



Figure 5. Safe Pushing

## Braking Information

Scooters are equipped with three brake systems—a handbrake lever, a supplemental brake, and a parking brake. The brake levers must be activated manually to slow the vehicle to near stop. Refer to “II. Your Scooter” for braking information.

Unless equipped with a specialty device, the speed of your scooter is controlled by a twist throttle. When the twist throttle is moved from the neutral position, the scooter will begin to move forward. The more pressure applied to the twist throttle, the faster the vehicle will move up to a preset maximum speed. When the twist throttle is released back to the center (neutral) position, the electronic signal is reversed and forward acceleration is stopped. The manual handbrake must be engaged to come to a controlled stop.

**NOTICE:** *If the twist throttle is released to the neutral position when negotiating an incline, the scooter may “roll back.” Engage brake lever to stop the scooter from rolling back.*

## Cornering Information

Excessively high cornering speeds can still create the possibility of tipping. Factors which affect the possibility of tipping include, but are not limited to: cornering speed, steering angle (how sharply you are turning), uneven surfaces, inclined surfaces, riding from an area of low traction to an area of high traction (such as passing from a tiled area to a carpeted area – especially at high speed while turning), and abrupt directional changes. High cornering speeds are not recommended. If you feel that you may tip over in a corner, reduce your speed and steering angle (i.e., lessen the sharpness of the turn) to prevent your scooter from tipping.



**WARNING!** When cornering sharply, reduce your speed and maintain a stable center of gravity. Avoid shifting your weight in the opposite direction of the turn, which may cause the scooter to lose traction and tip over.

# I. SAFETY

## Stationary Obstacles (Steps, Curbs, etc.)

Proceed with extreme caution when driving near raised surfaces, unprotected curbs and/or drop-offs (curbs, porches, stairs, etc.). Refer to the scooter specifications for information regarding maximum obstacle climbing height for your scooter.

### To navigate up over a curb or stationary obstacle:

1. Approach the curb or obstacle slowly, and make sure the scooter is traveling perpendicular to the obstacle. **See figure 6.**
2. Increase the forward speed just before the front wheel come in contact with the obstacle.
3. Reduce the forward speed only after the rear wheels have cleared the obstacle.

### To navigate down a curb or stationary obstacle:

1. Approach the curb or obstacle slowly, and make sure the scooter is traveling perpendicular to the obstacle. **See figure 6.**
2. Reduce the forward speed just before the front wheel comes in contact with the obstacle.
3. Increase the forward speed only after the rear wheels has cleared the obstacle and you are once again on a level surface.

**WARNING! Even though your scooter may be capable of handling greater obstacles, we recommend that you do not attempt to negotiate a curb that has a height greater than 1.5 in. (4 cm). Doing so could cause instability in your scooter.**

**WARNING! Do not attempt to have your scooter climb or descend an obstacle that is inordinately high.**

**WARNING! Do not attempt to have your scooter proceed backward down any step, curb, or other obstacle. This may cause the scooter to tip.**

**WARNING! Do not approach curbs at an angle; instead, approach any curb you intend to ascend or descend in the forward position.**

**WARNING! The iRide is intended for operation on flat, even surfaces whether indoors or outdoors. Examples of "indoors" typically include, but are not limited to, linoleum, hardwood, tile, non-pile and low-pile carpeting. Examples of "outdoors" typically include, but are not limited to, concrete, asphalt, macadam, and certain refined brick configurations. Do not operate your scooter on or near uneven surfaces such as stairs, drop-offs, ledges, grass, gravel, sand, mulch, dirt, mud or deteriorated concrete, asphalt or other uneven surfaces. Failure to heed this warning may result in damage to the product or cause instability and tipping resulting in personal injury or death.**

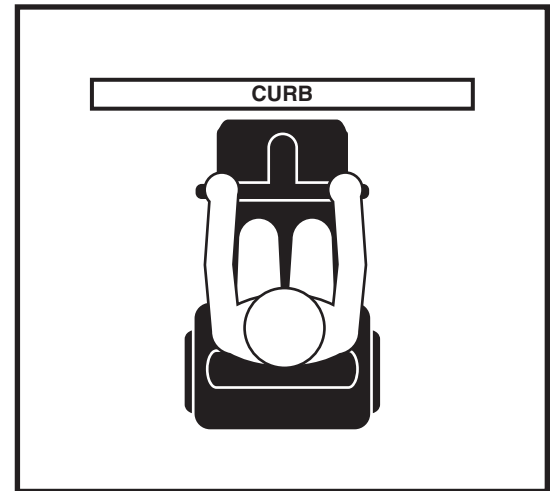

Figure 6. Correct Curb Approach



Figure 7. Incorrect Curb Approach

# I. SAFETY

## Ingress of Liquids



**WARNING!** Even though the scooter has passed the necessary testing requirements for ingress of liquids, you should keep electrical connections away from sources of dampness, including direct exposure to water or bodily fluids and incontinence. Check electrical components frequently for signs of corrosion and have them replaced as necessary.

**WARNING!** Never take your scooter into a shower, tub, pool, or sauna. Do not operate your scooter in water.

## Stairs and Escalators

Scooters are not designed to travel up or down stairs or escalators. Always use an elevator.

**WARNING!** Never use your scooter to negotiate stairs or escalators.



**WARNING!** Use extreme caution when it is necessary to move an unoccupied scooter up or down stairs. We recommend that two attendants perform this task, and that the seat, batteries, and any accessories be removed before attempting the transfer. Use proper lifting techniques and use only solid, non-removable frame components to lift the scooter.

## Elevators

Modern elevators have a door edge safety mechanism that, when pushed, reopens the elevator door(s).

- If you are in the doorway of an elevator when the door(s) begin to close, push on the rubber door edge or allow the rubber door edge to contact the scooter and the door will reopen.
- Use care that pocketbooks, packages, or scooter accessories do not become caught in elevator doors.

*NOTICE: If your scooter's turning radius is greater than 60 in. (152 cm), it may be difficult to maneuver in elevators and building entrances. Use caution when attempting to turn or maneuver your scooter in small spaces and avoid areas that might pose a problem.*

## Doors

- Determine if the door opens toward or away from you.
- Drive your scooter gently and slowly forward to push the door open, or push your scooter gently and slowly backward to pull the door open.

## Unoccupied Motor Vehicle Transport

Do not remain seated in your scooter while traveling in a motor vehicle. The scooter should be stowed in the trunk of a car or in the back of a truck or van with seat removed and/or properly secured. In addition, all removable scooter parts should be removed and/or properly secured during motor vehicle transport.



**WARNING!** The scooter user should transfer into the motor vehicle seat and use the vehicle-installed restraint system if and whenever feasible. The scooter user should never sit on the scooter while it is in a moving vehicle.



**WARNING!** Always be sure your scooter and its seat are properly secured when it is being transported. Batteries should not be transported with any flammable or combustible items.

## Seating



**WARNING!** Should the fittings on your seat become loose, report the problem immediately to your authorized dealer.



**WARNING!** Do not remove the seat cushion supplied with the scooter. Do not place additional cushions, padding, or pillows on the seat cushion. This could cause an unstable position, resulting in a fall from the scooter.

# I. SAFETY

## Batteries and Charging: Lithium-Ion

In addition to following the warnings below, be sure to comply with all other battery handling information provided in III. “Batteries and Charging” of this owner’s manual.

**WARNING! Airlines have strict guidelines for transporting Lithium-Ion batteries onboard passenger airplanes. Check with airline prior to travel.**

**WARNING! Only use batteries authorized by your Dealer. Refer to the specifications provided with the scooter and in the manual supplied with the battery charger for recommended type and capacities. The only battery offered is already in an assembly that cannot be opened. You must go to your authorized Dealer.**

**WARNING! This battery has been tested and complies with United Nations Transport Regulations standard UN38.3.**

**WARNING! Always ensure that the Lithium-Ion battery charger supplied with your scooter is used to recharge your battery. Using a different or non-Lithium charger may result in diminished scooter performance, including diminished range per charge. Failure to heed this warning may result in product damage, personal injury, or death.**

**WARNING! Always protect the battery from freezing and never charge a frozen battery. Charging a frozen battery may result in damage to the battery.**



**WARNING! Always operate charger in a well-ventilated area as it is essential for proper cooling. Ensure vent holes are clear of blockages before use and always place the charger on a hard, flat surface during charging. Before each use, ensure the charger is not covered with any items such as blankets or articles of clothing. Do not place the charger in enclosed areas such as pouches or bags. Failure to allow for proper ventilation may result in damage to the charger.**

**WARNING! Check battery box for signs of damage. If any battery or battery box appears damaged, contact your authorized Dealer immediately.**

**WARNING! Be aware that the battery charger case may become hot during charging. Avoid skin contact and do not place the charger on surfaces that may be affected by heat including carpeting or clothing.**

**WARNING! If the battery charger is equipped with cooling slots, then do not attempt to insert objects through these slots and keep the cooling slots free from objects.**

**WARNING! Do not charge in direct sunlight or near heat sources.**

**WARNING! Contact your authorized Dealer if you have any questions regarding the battery in your scooter.**

**WARNING! Do not open the battery pack. There are no serviceable parts inside.**



# I. SAFETY

## Removable Parts



**WARNING!** Do not attempt to lift or move your scooter or seat by grasping or holding onto any of its removable parts. Grasp only solid, non-removable frame components to lift or move your scooter or seat.

## Preventing Unintended Movement



**WARNING!** If you anticipate being seated in a stationary position for an extended period of time, disconnect the controller and battery connectors. This will prevent unexpected motion from inadvertent twist throttle contact. This will also eliminate the possibility of unintended scooter movement from electromagnetic (EM) sources.

## Reaching and Bending

Never reach, lean, or bend while driving your scooter. Bending forward creates the risk of accidental twist throttle contact. Bending to the side while seated creates the risk of tipping. If it is absolutely necessary to reach, lean, or bend while seated on your scooter, it is important to maintain a stable center of gravity and keep the scooter from tipping. Make sure the wheels are pointed in the forward position to create the longest possible wheelbase. We recommend that the scooter user determine his/her personal limitations and practice bending and reaching in the presence of a qualified attendant. See figures 8 and 9.

**WARNING!** Do not bend, lean, or reach for objects if you have to pick them up by reaching down between your knees, if you have to lean from either side of the scooter, or if you have to reach over the back of the seat. Movements such as these may change your center of gravity and the weight distribution of the scooter. This may cause your scooter to tip.



**WARNING!** Keep your hands, clothing, and all other objects away from the tires when driving. Do not allow any personal belongings or objects to drag behind the scooter when driving. Be aware that loose fitting clothing or other objects can become caught in drive wheels and/or they may become entangled in the running gear.



**WARNING!** Possible strangulation hazard! Be aware that clothing, lanyards, necklaces, other jewelry, purses, and other accessories worn or carried by you while you are seated on or operating the scooter may get caught around the armrests or twist throttle. Be careful to avoid this potential danger.

**WARNING!** Do not allow objects or accessories to protrude from your scooter when driving. Be aware protruding objects can become caught on items surrounding the scooter's path.



Figure 8. Proper Reaching and Bending

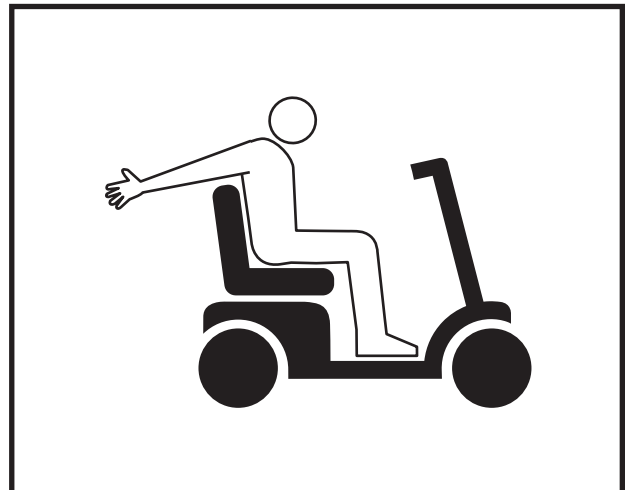

Figure 9. Improper Reaching and Bending



# I. SAFETY

## Transfers

Transferring onto and off of your scooter requires a good sense of balance. Always have an attendant present while learning to properly transfer.

To eliminate the possibility of injury, we recommend that you or a trained attendant perform the following tasks before attempting a transfer:

- Turn off power button on battery box.
- Ensure the parking brake is engaged. See “Your Scooter” in this owner’s manual.
- Make sure the seat is fixed securely in place.

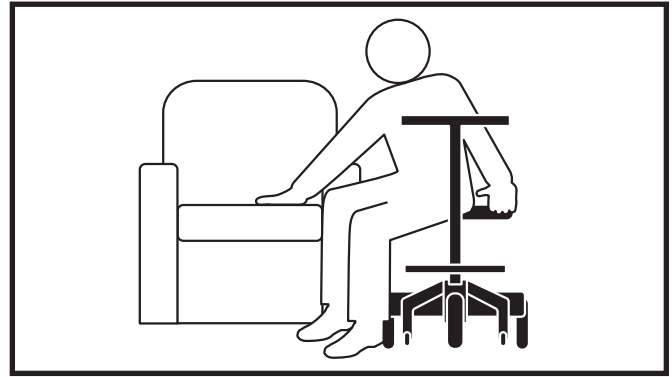

Figure 10. Recommended Transfer Position

**WARNING! Before transferring, engage the parking brake.**

**WARNING! Before transferring, position yourself as far back as possible in the scooter seat to prevent the scooter from tipping forward during transfer.**



**WARNING! Avoid putting all of your weight on the scooter tiller. Such use may cause the scooter to tip, resulting in a fall from the scooter and personal injury.**

**WARNING! Avoid putting all of your weight on the scooter foot pegs. Such use may cause the scooter to tip.**

## Physical Limitations

Users must exercise care and common sense when operating a scooter. This includes awareness of safety issues that arise because of particular physical limitations of the scooter user.



**WARNING! Do not operate your scooter if your ability to operate the scooter safely is impaired in any way. Examples include, but are not limited to, a lack of awareness of surroundings or lack of capacity to think clearly; impaired vision or hearing; or impaired dexterity of upper extremities that limits the capacity to use controls or steer. Operating this scooter while impaired in any way may result in erratic steering, acceleration, braking, instability, tipping, misdirection, and/or collision with persons or objects. Any of these circumstances can result in serious personal injury or death.**

## Drugs/Medications

Users must exercise care and common sense when operating a scooter. This includes awareness of safety issues that arise when taking prescribed or over-the-counter drugs/medications.



**WARNING! Consult with your physician if you are taking prescribed or over-the-counter drugs/medications. Some drugs/medications may impair your ability to operate your scooter safely. Operating this scooter while impaired may result in erratic steering, acceleration, braking, instability, tipping, misdirection, and/or collision with persons or objects. Any of these circumstances can result in serious personal injury or death.**

## Alcohol and Other Intoxicants/Smoking

Users must exercise care and common sense when operating a scooter. This includes awareness of safety issues that arise after consuming alcohol and other intoxicants, including marijuana and various forms of narcotics.



**WARNING! Do not operate your scooter while you are under the influence of alcohol or other intoxicants, including marijuana and other forms of narcotics, which may impair your ability to operate your scooter safely. Operating this scooter while impaired may result in erratic steering, acceleration, braking, instability, tipping, misdirection, and/or collision with persons or objects. Any of these circumstances can result in serious personal injury or death.**

# I. SAFETY

## Smoking

Users must exercise care and common sense when operating a scooter. This includes awareness of safety issues that arise from smoking which may impair your ability to operate your scooter in a safe manner.

**WARNING! Do not operate your scooter while smoking. Smoking may impair your ability to operate your scooter safely or cause a fire. Operating a scooter while smoking can distract the user from safely operating the scooter and can interfere with properly operating the scooter's controls which may result in erratic steering, acceleration, braking, instability, tipping, misdirection, and/or collision with persons or objects. Any of these circumstances may result in serious personal injury or death. Smoking while operating the scooter can also result in physical burns and/or scooter/property damage and can ignite a fire that can result in serious personal injury or death.**



**WARNING! We strongly recommend that you do not smoke cigarettes while seated in your scooter, even though the scooter has passed the necessary testing requirements for exposure to cigarette smoking. You must adhere to the following safety guidelines if you decide to smoke cigarettes while seated in your scooter.**

- Do not leave lit cigarettes unattended.
- Keep ashtrays a safe distance from the seat cushions.
- Always make sure cigarettes are completely extinguished before disposal.

## Flammability Precautions

**WARNING! Even though the plastics and seat used on your scooter have been tested and have passed flammability standards, we recommend that you do not expose your scooter to open flames.**



**WARNING! Exercise extreme caution when using oxygen in close proximity to electrical circuits and combustible materials. Contact your oxygen Dealer for information on using oxygen safely.**

**WARNING! Replace worn or damaged upholstery immediately to reduce the risk of fire hazard.**

**WARNING! Be aware that washing of upholstered items may reduce the resistance to flammability of the fabric.**

## Hazardous Environments



**WARNING! Due to the electrical make-up of our products, we do not recommend use of our scooters in Class I Division I industrial or commercial environments where the work area could have a combustible air composition. In such an environment, it is possible for the scooter to become an ignition source for a fire or explosion.**

# I. SAFETY

## Sports and Athletics

The scooter user must exercise care and common sense when operating his/her scooter. This includes awareness of safety issues while participating in sports and athletics. All sports activities run the risk of injury. We recommend that your scooter be equipped with a positioning belt and that you use sports safety equipment such as helmets and padding if you choose to participate in sports activities.

In addition, it is your responsibility to inform your authorized Dealer if you will be participating in sports and athletics. Your scooter may not be set up properly for sports activities in terms of both seat configuration and controller program. If you participate in sports activities of any kind, make sure your authorized Dealer has monitored your use of the scooter in this activity. This will aid your Dealer in configuring the scooter to suit your specific needs safely and comfortably. After any adjustments have been made, your Dealer should once again monitor your use of the scooter in this activity to ensure that you are comfortable with the new settings.



**WARNING! Participating in sports and athletics is done at the user's own risk. The scooter user is responsible for using proper safety equipment and for ensuring that his/her authorized Dealer has properly configured the scooter for such use. We will not be held liable for personal injury and/or product damage resulting from use of the scooter in any sports-related activity.**

## Electromagnetic and Radio Frequency Interference (EMI/RFI)



**WARNING! Laboratory tests have shown that electromagnetic and radio frequency waves can have an adverse effect on the performance of electrically-powered mobility vehicles.**

Electromagnetic and Radio Frequency Interference can come from sources such as cellular phones, mobile two-way radios (such as walkie-talkies), radio stations, TV stations, amateur radio (HAM) transmitters, wireless computer links, microwave signals, paging transmitters, and medium-range mobile transceivers used by emergency vehicles. In some cases, these waves can cause unintended movement or damage to the control system. Every electrically-powered mobility vehicle has an immunity (or resistance) to EMI. The higher the immunity level, the greater the protection against EMI. This product has been tested and has passed at an immunity level of 3 V/m.



**WARNING! Be aware that cell phones, two-way radios, laptops, electricity generators or high power sources, and other types of radio transmitters may cause unintended movement of your electrically-powered mobility vehicle due to EMI. Do not turn ON hand-held personal communication devices, such as citizens band (CB) radios and cellular phones, while the scooter is turned on. Be aware of nearby transmitters, such as radio or TV stations, and avoid coming into close proximity to them.**



**WARNING! The addition of accessories or components to the electrically-powered mobility vehicle can increase the susceptibility of the vehicle to EMI. Do not modify your scooter in any way not authorized by the scooter manufacturer.**

**WARNING! The electrically-powered mobility vehicle itself can disturb the performance of other electrical devices located nearby, such as alarm systems.**

**NOTICE:** For further information on EMI/RFI, contact your authorized Dealer. If unintended motion occurs, turn your scooter off as soon as it is safe to do so. Contact your authorized Dealer to report the incident.

# I. SAFETY

## Questions & Answers about Proposition 65

### What is Proposition 65?

Proposition 65 requires businesses to provide warnings to Californians about significant exposures to chemicals that cause cancer, birth defects, or other reproductive harm. These chemicals can be in the products that Californians purchase, in their homes or workplaces, or that are released into the environment. By requiring that this information be provided, Proposition 65 enables Californians to make informed decisions about their exposures to these chemicals.

Proposition 65 also prohibits California businesses from knowingly discharging significant amounts of listed chemicals into sources of drinking water. Proposition 65 requires California to publish a list of chemicals known to cause cancer, birth defects, or other reproductive harm. This list, which must be updated at least once a year, has grown to include approximately 900 chemicals since it was first published in 1987.

### What types of chemicals are in the Proposition 65 list?

The list contains a wide range of naturally occurring and synthetic chemicals that include additives or ingredients in pesticides, common household products, food, drugs, dyes, or solvents. Listed chemicals may also be used in manufacturing and construction, or they may be byproducts of chemical processes, such as motor vehicle exhaust.

### What does a warning mean?

If a warning is placed on a product label or posted or distributed at a workplace, a business, or in rental housing, the business issuing the warning is aware or believes that it is exposing individuals to one or more listed chemicals. By law, a warning must be given for listed chemicals unless the exposure is low enough to pose no significant risk of cancer or is significantly below levels observed to cause birth defects or other reproductive harm.

### Where can I get more information on Proposition 65?

If you have specific questions on the administration or implementation of Proposition 65, you can contact OEHHA's Proposition 65 program at [P65.Questions@oehha.ca.gov](mailto:P65.Questions@oehha.ca.gov), or by phone at (916) 445-6900.

## USER SAFETY NOTICE

Your safety is important to us. If there is any information in this manual which you do not understand, or if you require additional assistance for setup or operation, please contact your authorized Dealer. **Failure to follow the instructions, warnings, and notes in this manual and those located on your product can result in personal injury or product damage and will void the product warranty.**

## II. YOUR SCOOTER

### TILLER CONSOLE

The tiller console houses all controls needed to drive your scooter, including the battery condition meter, tiller display, and twist throttle. See figure 11.



**PROHIBITED! Do not expose the tiller console to moisture. In the event that the tiller console does become exposed to moisture, do not attempt to operate your scooter until the tiller console has dried thoroughly.**

#### IDENTIFICATION KEY

- |                       |                      |
|-----------------------|----------------------|
| 1. Handbrake Lever    | 6. LCD Display       |
| 2. Tiller Display     | 7. Speed Down Button |
| 3. Speed Up Button    | 8. Twist Throttle    |
| 4. Mode Select Button | 9. Parking Brake Pin |
| 5. Hand Grip          |                      |

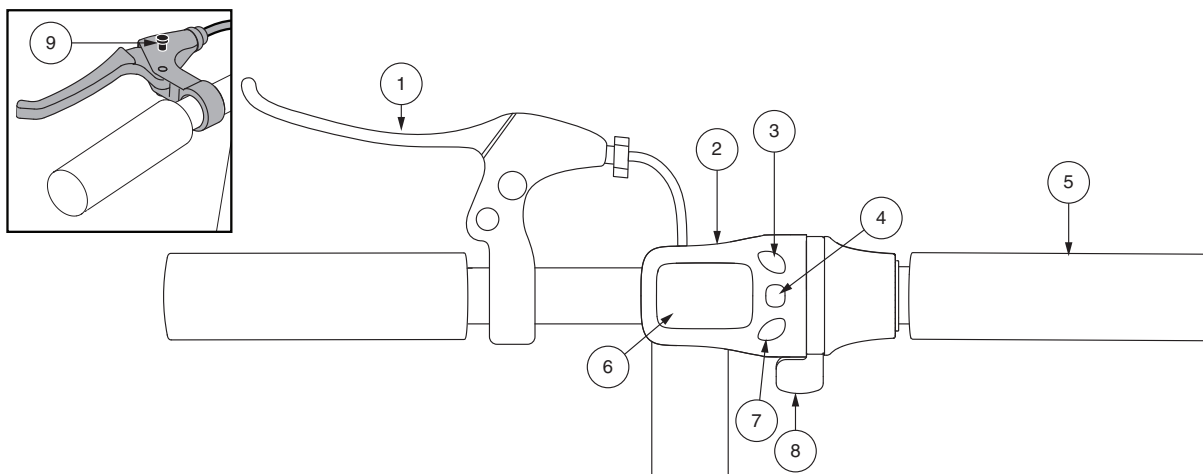

Figure 11. Tiller Console

### Power Button

- Push power button on battery pack to turn your scooter on. The power button also acts as the main circuit breaker. See figure 12.

### Twist Throttle

The twist throttle allows you to control the forward speed of your scooter.

- Place your right hand on the right handgrip and your left hand on the left handgrip.
- Use your right thumb to press the twist throttle control downward in order to control speed of forward movement.
- To slow your scooter, apply the handbrake.
- When the twist throttle is released, it automatically returns to the “stop” position.

### Mode Select Button

Allows you to toggle through modes and illuminate the LCD display.

- Press and hold the top portion of the mode select button for two seconds to illuminate the LCD display.
- Press the bottom portion of the mode select button to toggle through the available modes. From the drive profile mode, press + or - to cycle through the available drive profiles.

## II. YOUR SCOOTER

### Charger Power Cord Receptacle

The 2-pin end of the charger power cord plugs into this receptacle. See figure 13.

### Battery Condition Meter

When the power button is pressed to power up your scooter, this meter indicates the approximate battery voltage strength on your tiller display. For further information on battery charging, see III. “Batteries and Charging.”

### Drivetrain Assembly

The drivetrain assembly is an electromechanical unit that converts electrical energy from your scooter’s batteries into the controlled mechanical energy that drives the scooter’s wheels.

### Anti-Tip Wheels

The anti-tip wheels are an integral and important safety feature of your scooter. They are bolted to the frame at the rear of the scooter.



**PROHIBITED!** Do not remove the anti-tip wheels or modify your scooter in any way that is not authorized by your Dealer.



**WARNING!** The anti-tip wheels may cause interference with the smooth transition of your scooter when ascending or descending a curb. Contact your authorized Dealer for more information.

### Battery Pack

Your scooter is equipped with an innovative easy-to-remove Lithium-Ion battery pack. Refer to III. “Batteries and Charging” for battery pack replacement instructions. See figures 12 and 13.

### Main Circuit Breaker (Reset Button)

The power button also acts as the main circuit breaker. When the voltage in your scooter’s batteries becomes low or the scooter is heavily strained because of excessive loads or steep inclines, the main circuit breaker may trip to protect the motor and electronics from damage. See figure 12.

- The main circuit breaker reset button pops out when the breaker trips.
- When the breaker trips, the entire electrical system of your scooter shuts down.
- Allow a minute or two for your scooter’s electronics to “rest.”
- Push in the reset button to reset the main circuit breaker.
- If the main circuit breaker trips frequently, you may need to charge your batteries more often. You may also need to have your authorized Dealer perform a load test on your scooter’s batteries.
- If the main circuit breaker trips repeatedly, see your authorized Dealer for service.

### IDENTIFICATION KEY

1. Power Button/Main Circuit Breaker
2. Battery Strap
3. Battery Pack
4. Battery Connector

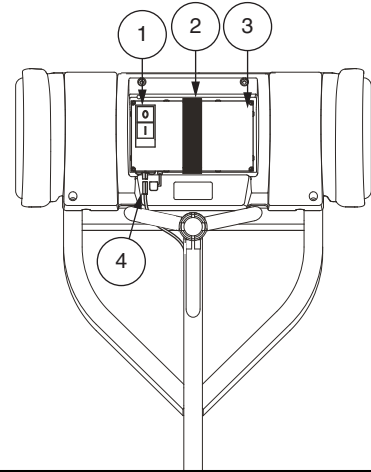

Figure 12. Battery Pack

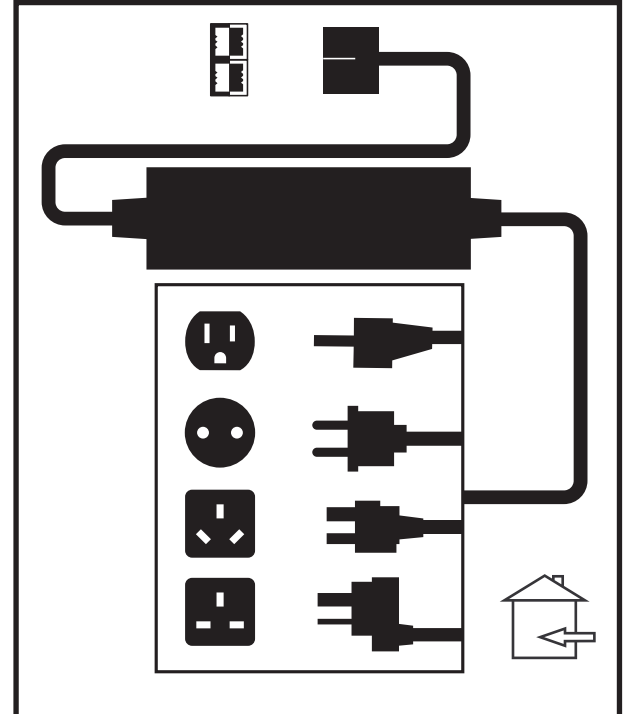

Figure 13. Off-board Battery Charger

## II. YOUR SCOOTER

### Off-Board Battery Charger

The off-board battery charger, when plugged into the charger power cord receptacle and a standard electrical outlet, charges the scooter's batteries. See figure 13.

### BRAKING

#### Handbrake Lever

Engage handbrake lever to slow or stop your scooter. See figure 15.

#### Supplemental Brake

Your scooter is equipped with a secondary, supplemental braking system located near the front wheel. See figure 14.

#### To apply supplemental braking system:

1. Release twist grip throttle.
2. Return tiller to center position.
3. Gently apply supplemental brake.

**NOTE:** Supplemental brake is intended for occasional use only and is not meant to be used as the primary braking system.

#### Parking Brake

Your scooter is equipped with a parking brake, which can be locked to prevent movement once your scooter has come to a complete stop. See figure 15.

#### To apply parking brake:

1. Engage the handbrake lever.
2. Fully engage the parking brake pin.
3. Release the handbrake lever.
4. To release parking brake, fully squeeze the handbrake lever.

**WARNING!** The supplemental brake is not to be used as the primary brake system to stop your scooter. The supplemental brake should only be used as a secondary brake. Improper use of the braking systems may result in personal injury or property damage.



**WARNING!** Do not modify the handbrake lever in any way. If damage occurs, contact your authorized dealer for handbrake replacement.

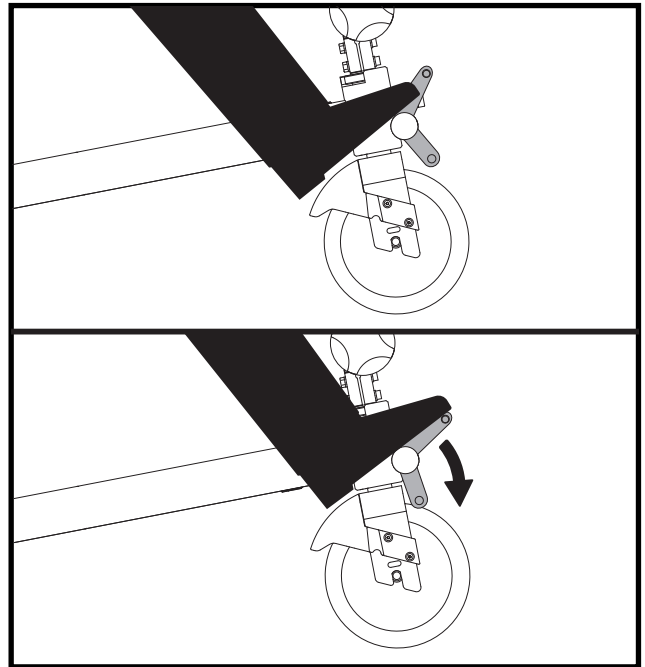

Figure 14. Supplemental Brake

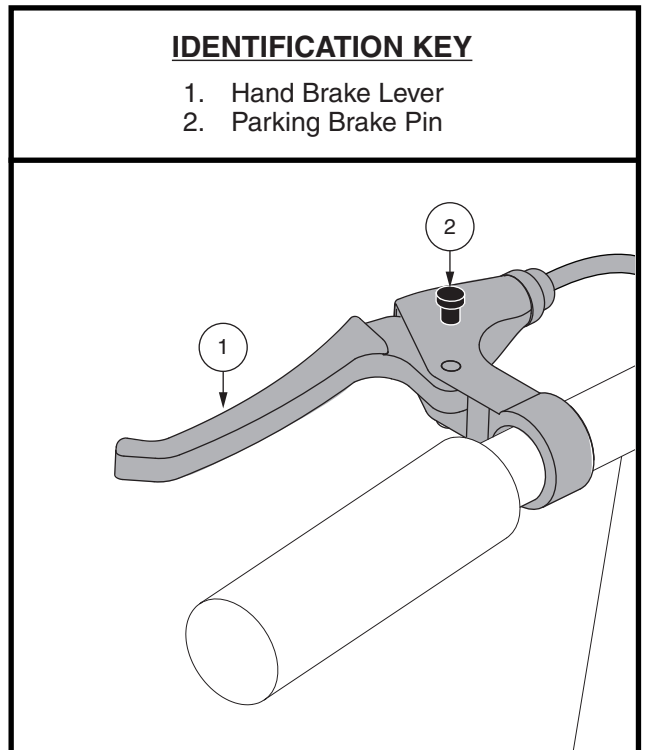

Figure 15. Handbrake Lever and Brake Lock (in the Locked Position)



# III. BATTERIES AND CHARGING

## BATTERIES AND CHARGING

Your scooter requires one long lasting, 36 volt Lithium-Ion battery that is sealed and maintenance-free.

- Charge your scooter's battery for at least 8 to 14 hours prior to using it for the first time.
- Keep the battery fully charged to keep your scooter running smoothly.

## READING YOUR BATTERY VOLTAGE

The battery condition meter on the throttle console indicates the approximate strength of your battery using a battery icon. At full charge, the icon will display five (5) bars indicating a fully charged battery. With continued use, the bars will begin to disappear as your charge drains. Once the icon is down to displaying only one bar, an immediate recharge is necessary. See figure 16. To ensure the highest accuracy, the battery condition meter should be checked while operating your scooter at full speed on a dry, level surface.

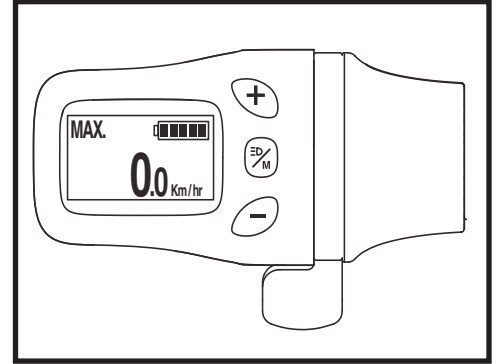

Figure 16. Battery Condition Meter

## CHARGING YOUR BATTERY



**PROHIBITED!** Never use an extension cord to plug in your battery charger. Plug the charger directly into a properly wired standard electrical outlet.



**PROHIBITED!** Do not allow unsupervised children to play near the scooter while the battery is charging. We recommend that you do not charge the battery while the scooter is occupied.



**MANDATORY!** Read the battery charging instructions in this manual and in the manual supplied with the battery charger before charging the battery.



**WARNING!** Explosive gases may be generated while charging the battery. Keep the scooter and battery charger away from sources of ignition such as flames or sparks and provide adequate ventilation when charging the battery.

**WARNING!** You must recharge your scooter's battery with the supplied off-board charger. Do not use an automotive-type battery charger.

**WARNING!** Inspect the battery charger, wiring, and connectors for damage before each use. Contact your authorized Dealer if damage is found.



**WARNING!** Do not attempt to open the battery charger case. If the battery charger does not appear to be working correctly, contact your authorized Dealer.

**WARNING!** If the battery charger is equipped with cooling slots, then do not attempt to insert objects through these slots.

**WARNING!** Be aware that the battery charger case may become hot during charging. Avoid skin contact and do not place on surfaces that may be affected by heat.



**WARNING!** Your battery charger has not been tested and approved for outdoor use. Do not expose it to adverse or extreme weather conditions. If the battery charger is exposed to adverse or extreme weather conditions, then it must be allowed to adjust to the difference in environmental conditions before use indoors. Refer to the manual supplied with the battery charger for more information. Your scooter should only be charged in an area where the room temperature is between 32°F/0°C and 113°F/45°C.



# III. BATTERIES AND CHARGING

Follow the 6 easy steps in figure 17 to charge your batteries safely:

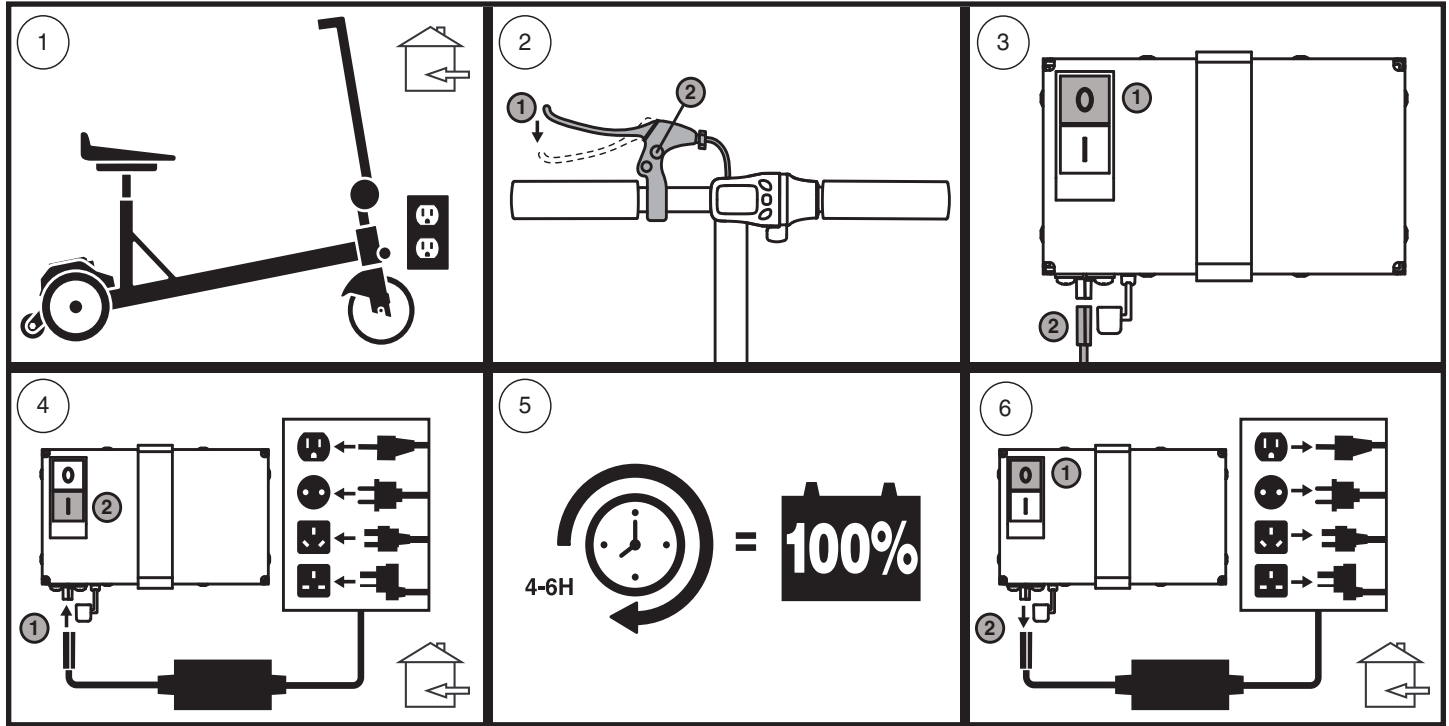

Figure 17. Battery Charging Procedures Diagram



**WARNING!** The LED lights on the charger indicate different charger conditions at various times. If the LED does not indicate that charging is complete within 24 hours, unplug the charger from the outlet and contact your Dealer. Refer to the operating instructions supplied with the charger for a complete explanation of these indicators.

## FREQUENTLY ASKED QUESTIONS

### How does the charger work?

When your scooter's battery voltage is low, the charger works harder, sending more electrical current to the battery to bring up its charge. As the battery approaches a full charge, the charger sends less and less electrical current. When the battery is fully charged, the current sent from the charger is at nearly zero amperage. Therefore, when the charger is plugged in, it maintains the charge on your scooter's battery, but does not overcharge them. Refer to the manual supplied with the battery charger for charging instructions.

### Can I use a different charger?

Chargers are selected precisely for particular applications and are especially matched to the type, size, and chemical formulation of specific batteries. For the safest and most efficient charging of your scooter's batteries, we recommend use of the charger supplied as original equipment with your product only.

### What if my scooter's battery will not charge?

- Ensure that the circuit breaker on the battery pack is in working condition.
- Ensure both ends of the charger power cord are inserted fully.

## III. BATTERIES AND CHARGING

### **How often must I charge the battery?**

Many factors come into play when deciding how often to charge the battery. You may use your scooter all day on a daily basis or you may not use it for weeks at a time.

- If you use your scooter on a daily basis, charge the battery as soon as you are finished using your scooter. Your scooter will be ready each morning to give you a full day's service. It is recommended that you charge the battery at least 4 to 6 hours after daily use. It is recommended that you charge your battery for an additional 4 hours after the battery charger indicates that charging is complete.
- If you use your scooter infrequently (once a week or less), you should charge the battery at least once per week for 4 to 6 hours.

***NOTE:** Keep your battery fully charged and avoid deeply discharging your battery. Refer to the manual supplied with the battery charger for charging instructions.*

### **How can I ensure maximum battery life?**

A fully charged battery will provide reliable performance and extended battery life. Keep your scooter's battery fully charged whenever possible.

***NOTE:** The useful life of a battery is quite often a reflection of the care it receives.*

### **What type and size of battery should I use?**

Only use the battery supplied by Manufacturing/Authorized Dealers.

# III. BATTERIES AND CHARGING

**NOTE:** Sealed batteries are not serviceable. Do not remove the caps.

## What about public transportation?

Your iRIDE Lithium-Ion battery has been tested and complies with United Nations Transport Regulations standard UN38.3 and conforms to 49 CFR 175.10(a)(17).

**NOTE:** Airline policies and regulations may vary. Check with individual airline prior to travel.

## How do I change the battery in my scooter?



**MANDATORY!** All iRIDE batteries must be purchased from an authorized Dealer. The battery pack must not be opened.

**WARNING!** Contact your Dealer if you have any questions regarding the battery in your scooter.



**WARNING!** Do not replace the battery while the scooter is occupied.

**WARNING!** Do not pull on electrical lead wires directly to detach them from the scooter. Always grasp the connector itself when disconnecting the lead to prevent wire damage.

## To change the battery pack, see figure 18:

1. Ensure the battery pack power button is off.
2. Disconnect the black and red wires that go directly to the battery.
3. Unfasten the battery strap.
4. Remove the old battery pack from the scooter.
5. Install the new battery pack onto scooter.
6. Fasten the battery strap.
7. Connect the black and red wires on the new battery pack to the scooter.

**NOTE:** Contact your local waste disposal agency or authorized Dealer for information on proper battery disposal.

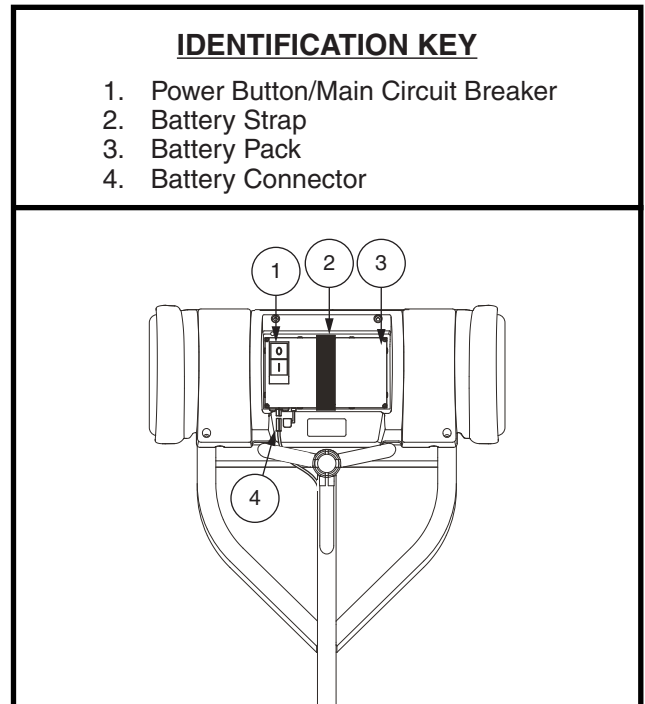

**Figure 18. Battery Pack Replacement**

# IV. OPERATION

## PRE-RIDE SAFETY CHECK

Get to know the feel of your scooter and its capabilities. We recommend that you perform a safety check before each use to make sure your scooter operates smoothly and safely.

### Perform the following inspections prior to using your scooter:

- Check the condition of the tires. Make sure they are not damaged or excessively worn.
- Check all electrical connections. Make sure they are tight and not corroded.
- Check all lead connections. Make sure they are secured properly.
- Check the brakes to ensure they operate properly.
- Check the battery condition meter to ensure the battery is fully charged.
- Ensure the parking brake is engaged before sitting on the scooter.

## PRE-RIDE ADJUSTMENTS AND CHECKS

- Is the seat secured into place?
- Is your proposed path clear of people, pets, and obstacles?
- Have you planned your route to avoid adverse terrain and as many inclines as possible?

*NOTE: Use caution when operating your scooter on delicate surfaces as scuffing and/or marking may occur.*

## BEFORE GETTING ONTO YOUR SCOOTER

- Have you fully charged the battery? See III. “Batteries and Charging.”
- Ensure the tiller release knob is in the locked position. See VI. “Disassembly and Assembly.”
- Ensure the parking brake is engaged.
- Ensure the air temperature is between -4°F/-20°C to 140°F/60°C.
- Ensure the power switch is in the “OFF” position. See **figure 12**.

## GETTING ONTO YOUR SCOOTER

1. Stand at the side of your scooter.



**WARNING! Never attempt to get onto or off your scooter with the scooter “ON”. Ensure parking brake is engaged prior to sitting on the scooter.**

2. Make certain that the seat is secured into position.
3. Position yourself comfortably and securely in the seat.
4. Turn the power button “ON.”
5. Make certain your feet are safely on the foot pegs.

# IV. OPERATION

## OPERATING YOUR SCOOTER



**WARNING! The following can adversely affect steering and stability while operating your Scooter:**

- Holding onto or attaching a leash to walk your pet.
- Carrying passengers (including pets).
- Hanging any article from the tiller.
- Towing or being pushed by another motorized vehicle.

**WARNING! Keep both hands on the tiller and your feet on the foot pegs at all times while operating your Scooter. This driving position gives you the most control over your vehicle.**

- Push power button on. See figure 12.
- Pull the appropriate side of the handle bar grips. Right if you want to go right, left if you want to go left.
- Always start in the lowest speed setting. Push decrease speed button on the tiller console. See figure 11.
- Rotate the twist throttle toward you to move forward.
- To go straight, move to the center position.
- To stop, release the twist throttle and engage the handbrake.

## GETTING OFF OF YOUR SCOOTER

1. Bring your Scooter to a complete stop.



**WARNING! Never attempt to get onto or off of your scooter with it still on. This will prevent the Scooter from moving if accidental twist throttle contact is made.**

2. Press the “OFF” button on the battery pack.
3. Set the parking brake by engaging the handbrake lever and engage the locking pin.
4. Carefully and safely get out of the seat and stand to the side of your Scooter.

# V. COMFORT ADJUSTMENTS

## SEAT HEIGHT ADJUSTMENT

The seat can be repositioned to different heights. See figure 19.

1. Loosen the cam lever.
2. Remove bowtie cotter pin from clevis pin by rotating it and removed it from the hole in the end of the clevis pin.
3. Remove clevis pin from the seat post.
4. Raise or lower the seat and its attached seat post to the desired seat height
5. While holding the seat at the desired height, align the adjustment holes of the seat with the lower seat post slot.
6. Fully insert clevis pin
7. Insert the open end of bowtie cotter pin into the hole at the end of the clevis pin and rotate it until the rounded section is around the clevis pin.
8. Tighten the cam lever.

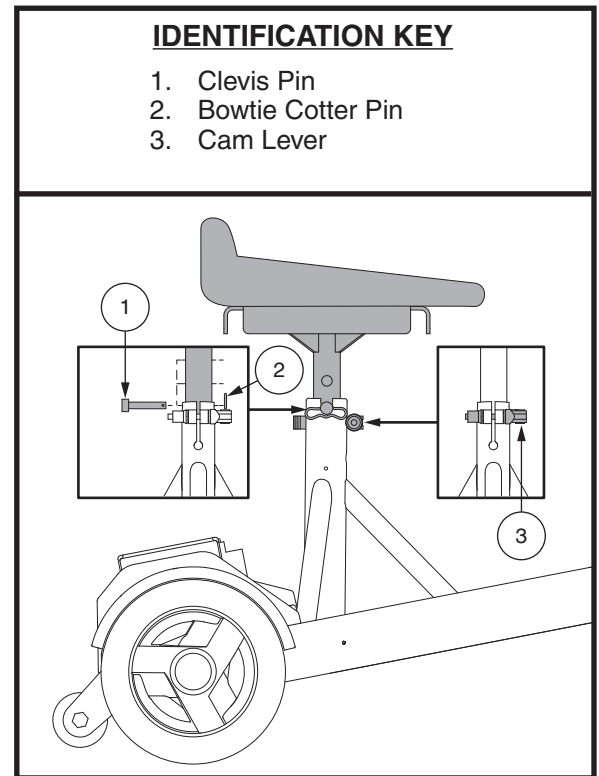

Figure 19. Seat Height Adjustment

# VI. DISASSEMBLY AND ASSEMBLY

## DISASSEMBLY

For your convenience, the iRIDE can be disassembled for storage and transport.



**WARNING! Do not lift weight beyond your physical capability. Ask for assistance when needed while disassembling or assembling your scooter.**

## BATTERY POWER DOWN

Ensure the battery pack is turned “OFF.” See figure 12.

## SEAT REMOVAL

1. Loosen the cam lever.
2. Remove the seat by lifting it straight up and off of the scooter.

## TILLER RELEASE

To release the tiller, loosen the Tiller Release Knob until the tiller loosens and slowly folds down. See figure 20. If you encounter resistance when folding the tiller down, firmly grasp the center of the tiller and apply slight pressure to the tiller while pushing it downward.

*NOTE: In order to fully lower the tiller, you must first remove the seat.*

To secure the tiller in the vertical position, hold the tiller fully upright while tightening the Tiller Release Knob.

## SEAT REPLACEMENT

1. While holding the seat, align the adjustment holes on the seat and lower seat post slot and insert post. See figure 19.
2. Insert the detent pin into the lower seat post.
3. Tighten cam lever.

## BATTERY REMOVAL

1. Ensure the battery pack is turned “OFF.”
2. Unplug the battery connector from the battery pack.
3. Remove the battery strap and lift upward and remove the battery.

## FOLDING FOR TRANSIT

1. Loosen the tiller release knob until the tiller loosens and slowly folds down.
2. Tighten the tiller release knob.
3. Wrap the tiller strap firmly around the main beam using the reusable hook and loop fastener to secure the straps. See figure 21.

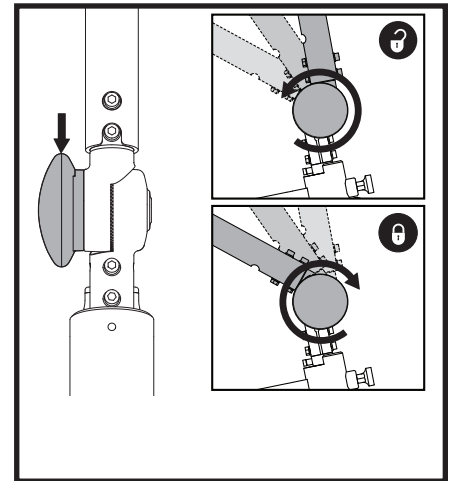

Figure 20. Tiller Release Knob

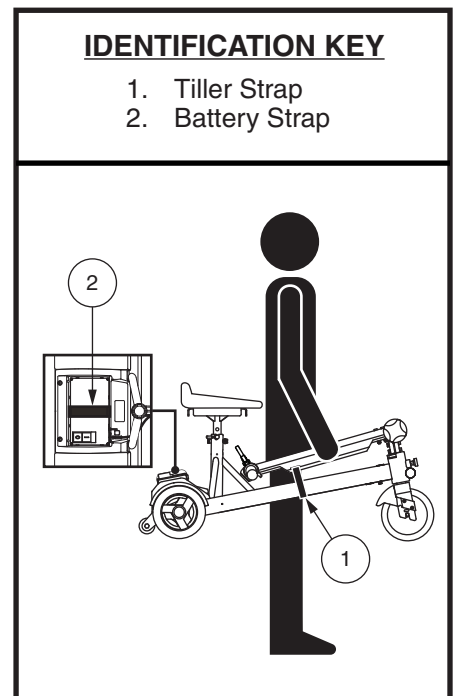

Figure 21. Folding for Transport

## VII. BASIC TROUBLESHOOTING

### **What if all the systems on my scooter seem to be “dead”?**

- Make certain that the power button is turned “ON.”
- Check that the battery is fully charged.
- Make sure that the battery pack and its wires are connected tightly and correctly.
- Make certain that the battery pack is seated properly.

### **What if the scooter’s battery won’t charge?**

- Ensure both ends of the charger power cord are connected properly.
- If the battery pack circuit breaker continually blows, contact your authorized Dealer for service.
- Ensure the power button on the battery pack is “ON.”

### **What if the main circuit breaker repeatedly trips?**

- If the main circuit breaker trips repeatedly, see your authorized Dealer for service.
- Charge the scooter’s battery pack more frequently. See III. “Batteries and Charging.”
- See III. “Batteries and Charging” or “Product Specifications Sheet” for information about your scooter’s battery type.



## VIII. CARE AND MAINTENANCE

Your scooter requires a minimal amount of care and maintenance. If you do not feel confident in your ability to perform the maintenance listed below, you may schedule inspection and maintenance at your authorized Dealer. The following areas require periodic inspection and/or care and maintenance.

### TIRES

Regularly inspect your scooter's tires for signs of damage or wear.

### WHEEL REPLACEMENT

Your scooter is equipped with solid tire inserts. If you have a damaged or worn tire, the entire wheel must be replaced. Contact your authorized Dealer for information regarding replacement wheels for your scooter.



**WARNING! Wheels on your scooter should only be serviced/replaced by a qualified technician.**  
**WARNING! Be sure that the scooter is "OFF" and the battery cord is not connected before performing this procedure.**

### EXTERIOR SURFACES

Bumpers, tires, and trim can benefit from an occasional application of a rubber or vinyl conditioner.



**WARNING! Do not use a rubber or vinyl conditioner on the scooter's vinyl seat or tire tread. They will become dangerously slippery.**

### CLEANING AND DISINFECTION

- Use a damp cloth and mild, non-abrasive cleanser to clean the plastic and metal parts of your scooter. Avoid using products that may scratch the surface of your scooter.
- If necessary, clean your product with an approved disinfectant. Make sure the disinfectant is safe for use on your product before application.



**WARNING! Follow all safety instructions for the proper use of the disinfectant and/or cleaning agent before applying it to your product. Failure to comply may result in skin irritation or premature deterioration of upholstery and/or scooter finishes.**

### BATTERY PACK CONNECTIONS

Make certain that the battery pack terminal connectors are tight and not corroded.

### WIRING LEADS

- Regularly check all wiring connections.
- Regularly check all wiring insulation, including the charger power cord, for wear or damage.
- Have your authorized Dealer repair or replace any damaged connector, connection, or insulation that you find before using your scooter again.



**PROHIBITED! Even though the scooter has passed the necessary testing requirements for ingress of liquids, you should keep electrical connections away from sources of dampness, including direct exposure to water or bodily fluids and incontinence. Check electrical components frequently for signs of corrosion and replace as necessary.**



**WARNING! Do not pull on electrical cords directly to detach them from the scooter. Always grasp the connector itself when disconnecting the cords to prevent wire damage.**

# VIII. CARE AND MAINTENANCE

## DAILY CHECKS

- With the power turned “OFF”, check the twist throttle. Make sure it is in the neutral position when you turn it. Do not try to repair it. See your authorized Dealer if there is a problem.
- Visually inspect all of the cables in the tiller. Make sure none are frayed, cut or have any wires exposed. See your authorized Dealer if there is a problem.
- Check for flat spots on solid tires. Flat spots could adversely affect stability.
- Check the brakes. This test should be carried out on a level surface with at least 3 feet (1 meter) of clearance around your scooter
- Check the brake handles and wires daily. Contact your authorized Dealer if there is a problem.

### To check the brakes:

1. Turn on the power on the battery pack.
2. Make sure all brake line connections are secure.
3. Rotate the twist throttle to accelerate and engage the brake lever towards you. Make sure the scooter slowly comes to a stop.

## WEEKLY CHECKS

- Inspect the tiller console, battery pack, and front tire for any corrosion. Contact your authorized Dealer if necessary.

## MONTHLY CHECKS

- Check for tire wear. See your authorized Dealer for repair.
- Keep your scooter clean and free of foreign material such as mud, dirt, hair, food, drink, etc.

## YEARLY CHECKS

Take your scooter to your authorized Dealer for yearly maintenance, especially if you use your scooter on a daily basis. This helps ensure that your scooter is functioning properly and helps prevent future complications.

## FENDERS

If your scooter has a fender with a **glossy finish**, the fender has been sprayed with a clear sealant coating. You can apply a light coat of car wax to help it retain its high-gloss appearance. If your scooter has a fender with a **matte finish**, use **ONLY** products developed for matte-finish paint. Do not use wax, detail spray, ArmorAll®, or any product made for glossy paint.



**WARNING! Carefully choose the correct product to protect the finish of your scooter's fender(s). ONLY products developed for matte-finish paint should be used on fenders with a matte finish. Failure to follow this warning may result in damage to the fender's matte paint finish.**

## AXLE BEARINGS AND DRIVETRAIN ASSEMBLY

These items are all prelubricated, sealed, and require no subsequent lubrication.

## CONSOLE, CHARGER AND REAR ELECTRONICS

- Keep these areas free of moisture.
- Allow these areas to dry thoroughly if they have been exposed to moisture before operating your scooter again.

## NYLON LOCK NUT REPLACEMENT

Any nylon insert lock nut removed during the periodic maintenance, assembly, or disassembly of the scooter must be replaced with a new nut. Nylon insert lock nuts should not be reused as it may cause damage to the nylon insert, resulting in a less secure fit. Replacement nylon insert lock nuts are available at local hardware stores or through your authorized Dealer.

## VIII. CARE AND MAINTENANCE

### STORING YOUR SCOOTER

If you plan on not using your scooter for an extended period of time, it is best to:

- Fully charge its battery prior to storage.
- Remove the battery pack from the scooter.
- Store your scooter in a warm, dry environment.
- Avoid storing your scooter where it will be exposed to temperature extremes.
- Recommended storage temperature: -40°F/-40°C to 149°F/65°C.

Batteries that are regularly and deeply discharged, infrequently charged, stored in extreme temperatures, or stored without a full charge may be permanently damaged, causing unreliable performance and limited service life. It is recommended that you charge the scooter battery periodically throughout periods of prolonged storage to ensure proper performance.



**WARNING! Always protect battery from freezing temperatures and never charge a frozen battery. Charging a frozen battery can result in damage to the battery.**

For prolonged storage, you may wish to place several boards under the frame of your scooter to raise it off of the ground. This takes the weight off the tires and reduces the possibility of flat spots developing on the areas of the tires contacting the ground.

### DISPOSAL OF YOUR SCOOTER

Your scooter must be disposed of according to applicable local and national statutory regulations. Contact your local waste disposal agency or authorized Dealer for information on proper disposal of packaging, metal frame components, plastic components, electronics, battery, neoprene, silicone, and polyurethane materials.



**WARNING! Plastic bags are a suffocation hazard. Dispose of plastic bags properly and do not allow children to play with them.**