

05/19



SUNNI SEAT

INSTRUCTIONS FOR USE



CONTENTS

1.0	Introduction.....	1
2.0	Illustration of Your Chair	2
2.1	Technical Data	2
3.0	For Your Safety	3
4.0	Unpacking Your Sunni Seat	9
5.0	Setting Up and Adjusting Your Sunni Seat.....	10
5.1	5-Point Harness	10
5.1.1	Adjusting the Base Strap	10
5.1.2	Adjusting the Harness	10
5.1.3	Unbuckling/buckling the Harness	11
5.2	Removing the cushions.....	12
5.2.1	Removing the Back Cushion	12
5.2.2	Removing the Base Cushion	12
5.3	Rotating the Base Clips.....	13
6.0	Accessories	14
6.1	Sunni Tray.....	14
6.2	Footrest.....	15
7.0	Safety Strap.....	16
7.1	Safety Strap Buckle.....	16
7.2	Safety Strap Toggle	17
8.0	Care and Maintenance	18
8.1	Daily Checks	19
8.2	Service Interval	19
8.3	Nominal Service Life	19
8.4	Extending Nominal Service Life	20
8.5	Documentation/Records.....	20
8.6	Product Configuration	20
9.0	Warranty & Service.....	21
10.0	Continuous Improvement	21
11.0	Service Inspection.....	22
11.1	Product Information.....	22
11.2	Service & Inspection Record Form	22



1.0 INTRODUCTION

Thank you for choosing the Sunni Seat from Smirthwaite Ltd in conjunction with Sunni.

This simple chair can be hooked onto a range of stools and seats to offer a higher level of postural support.



IMPORTANT!

These instructions should be read by all therapists and carers using the equipment and should be retained for future reference. The product should always be used under adult supervision.

Any incorrect use of the product and failure to follow the instructions may put the user at risk or impede the function. If you have any queries using this product or wish for further copies, please do not hesitate to contact Customer Service department

This product has been designed and manufactured specifically and solely for use by clients with special needs.



2.0 ILLUSTRATION OF YOUR CHAIR

- A - Main Frame
- B - Arm Rests
- C - Back Rest Cushion
- D - Base Cushion
- E - Base Clips
- F - 5 Point Harness

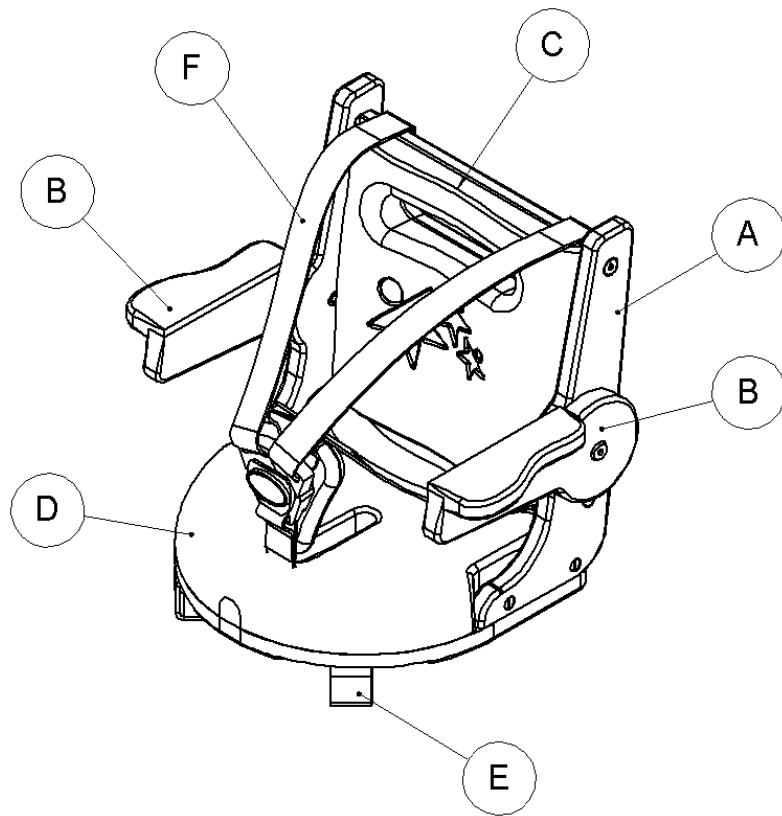

2.1 TECHNICAL DATA

Size	1	1 High Back	2	2 High Back
Code				
Dimension				
Overall Height (mm)	317	417	347	472
Back Height (mm)	253	353	283	308
Overall Width (mm)	350	350	430	430
Seat Width (mm)	226	226	276	276
Overall Depth (mm)	264	276	315	336
Seat Depth (mm)	210	210	258	267
User weight (kg)	15	15	25	25



3.0 FOR YOUR SAFETY



STOP!

Please read these instructions CAREFULLY and THOROUGHLY

- The user should NOT be left unattended whilst in the chair. Always ensure a responsible therapist or carer is in attendance.
- If you believe the chair or any fitted accessory to be faulty at any time, DO NOT USE – contact Smirthwaite by telephone
- The therapist should be familiar with the methods of adjustment and have completed all adjustments appropriately to meet the needs of the child before transferring the child onto the chair.
- The chair is ONLY to be used indoors on a flat level surface.
- DO NOT EXCEED USER MAXIMUM WEIGHT LIMITS
- Ensure chair is securely fastened onto any surface that the chair is being used upon.

Regular maintenance checks and cleaning are essential for the safe use of this equipment (see Section '0



4.0 ACCESSORIES

4.1 SUNNI TRAY

To attach the Sunni Tray;

- Place tray onto arm tops (ensuring tab (O) is in the open location).
- Twist tab (O) into the closed location to keep tray in place.

Open

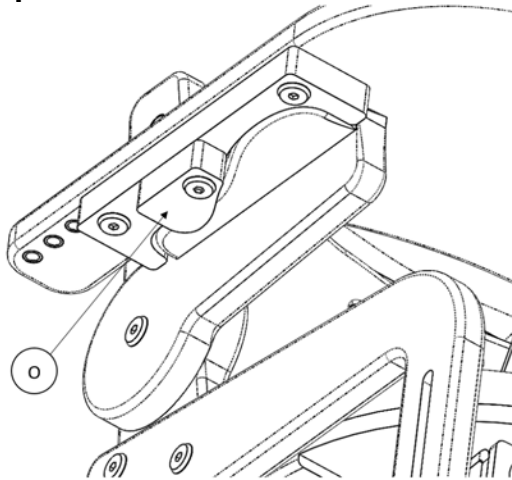

Closed

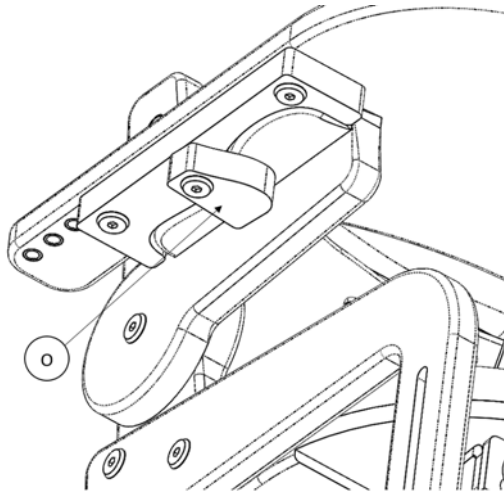

To adjust the tray depth;

- Remove bolts (N) (Two per side).
- Locate into desired position, using the holes on the bottom of the tray.
- Retighten the bolts (N) in desired location.

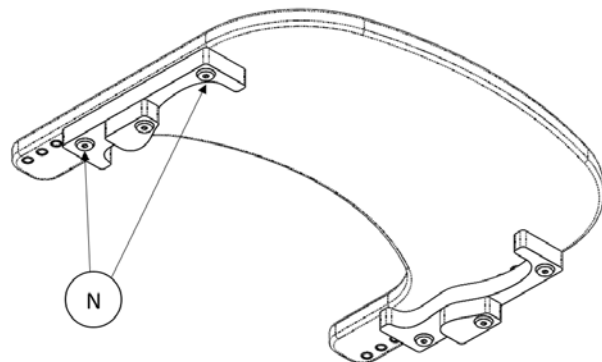

4.2 FOOTREST

To Attach the footrest;

- Align the holes on the side of the chair with the corresponding holes (P) in the footrest sides.
- Insert and tighten all four bolts (Q) (two per side)

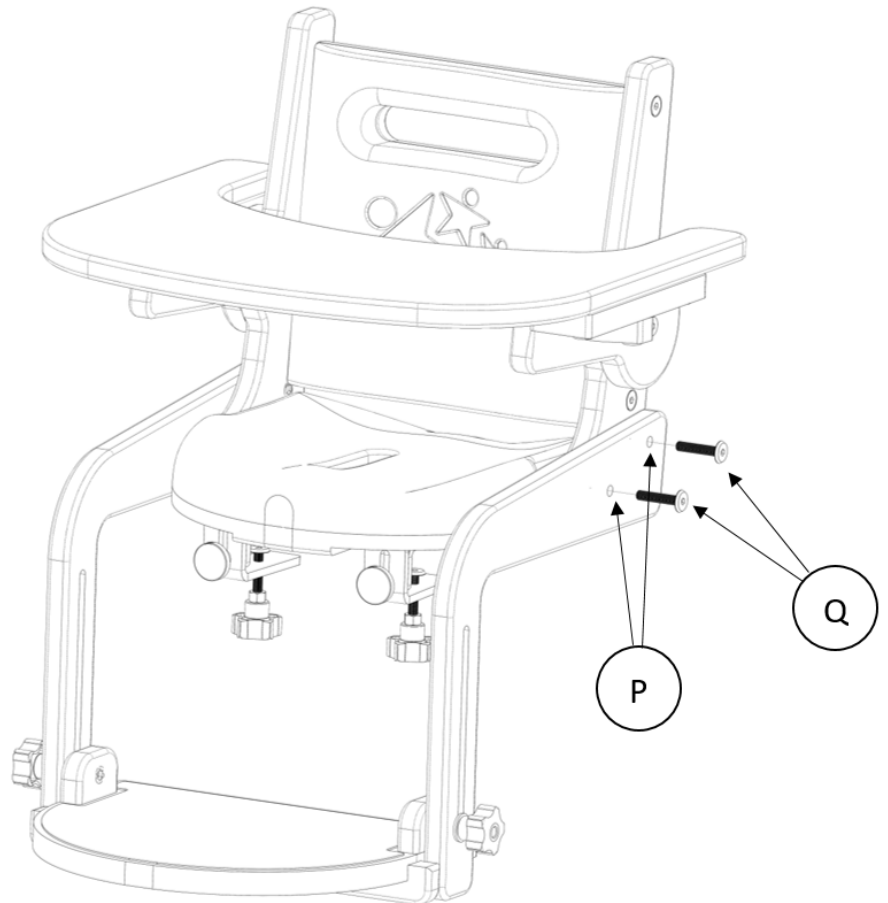

To adjust the height of the footrest;

- Loosen handwheels (R).
- Lift footplate to desired height.
- Retighten handwheels (R).

To Flip up the footplate;

- Loosen handwheels (R).
- Flip Footplate up 90 degrees
- Retighten handwheels (R).

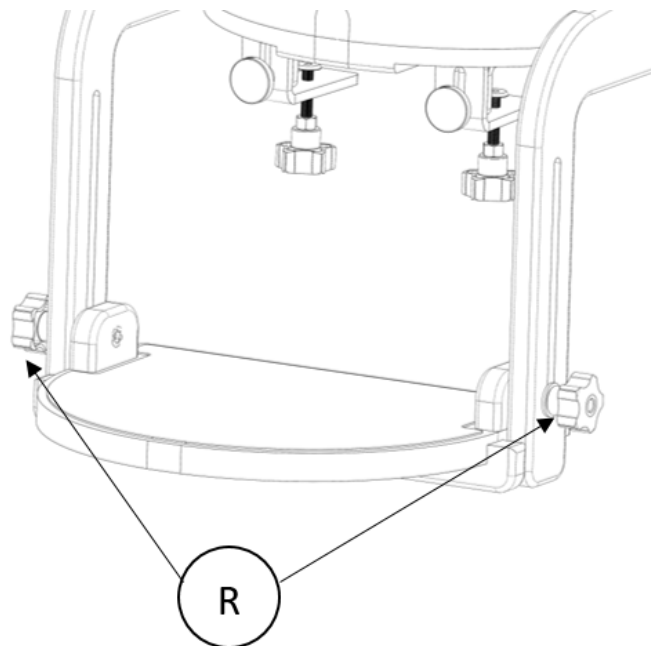

5.0 SAFETY STRAP

To Attach the safety strap;

- Loop strap (W) through slot (S) in the back of the seat.
- Thread the loose end of the strap (W) back through the buckle (T), pulling until tightly secured.
- Loop the other end of the strap (V) around the secure point.
- Thread the loose end of the strap (V) back through the buckle (T), pulling until tightly secured.
- Clip the buckle (U) together securing the Sunni to the secure point.
- Retighten both loose ends, ensuring the Sunni is completely secure.

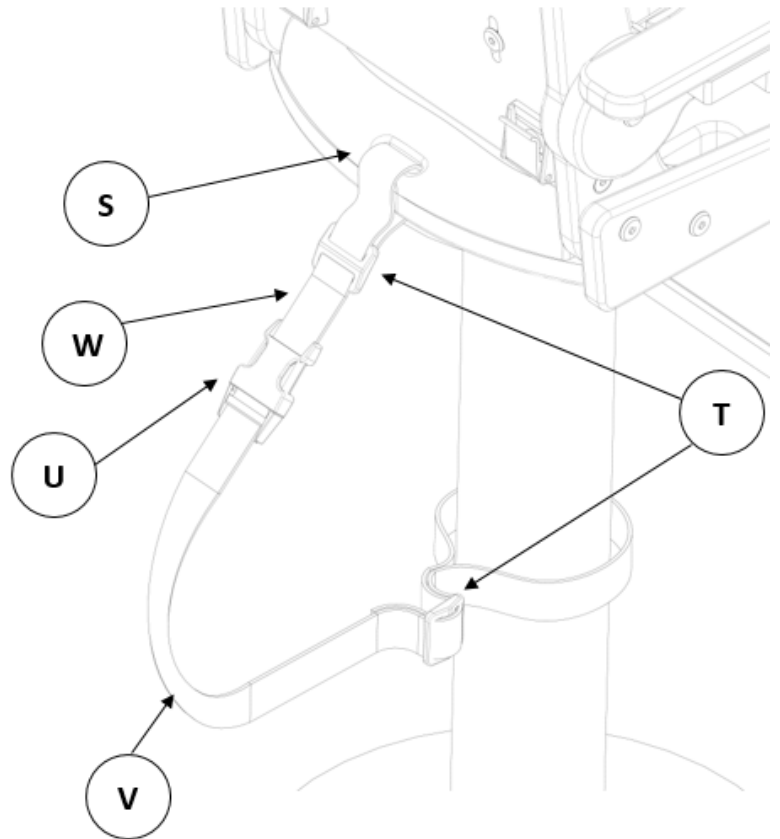

5.1 SAFETY STRAP BUCKLE

To operate the buckle;

- To fasten, simply connect the two parts, the buckle will 'click' and lock in place.
- To unfasten, press areas (X) to unlock the buckle and pull the two buckles apart.



5.2 SAFETY STRAP TOGGLE

To operate the safety strap toggle;

- Thread the end of the strap into the toggle (Y) in the direction of the grey arrows, looping out, around and down through the toggle (Y).
- Loop the free end of the strap around the desired object.
- Bring the loose end back through the toggle (Y) following the black arrows, looping out, around and down through the toggle (Y).
- To tighten, pull on the loose end of the strap.



- Care and Maintenance’).
- Always keep this product away from naked flames, cigarettes and sources of heat including open fireplaces, radiators, heaters.
- DO NOT fit parts or accessories of other manufacturers to this product unless authorised to do so in writing by Smirthwaite Ltd. Failure to follow these instructions will not only invalidate the guarantee but could make the chair dangerous to use.
- Smirthwaite Ltd will not accept liability for any injury or damage incurred through such malpractices. Any repairs required must be carried out by Smirthwaite Ltd authorised personnel.

If you believe this product to be faulty -DO NOT USE- Contact G&S Smirthwaite Ltd



6.0 UNPACKING YOUR SUNNI SEAT



STOP!

If in any doubt, **ALWAYS** seek **ADVICE**.

Always turn hand wheels, levers and screws clockwise to tighten or anti-clockwise to loosen.

- When delivered, the chair will be supplied fully assembled except for the attachment of any special accessories ordered.
- Please take note of any instructions on the packaging/box when unpacking.
- Once the chair has been carefully unpacked, please check all parts.



STOP!

If you believe this product to be faulty – DO NOT USE – Contact Smirthwaite Ltd



7.0 SETTING UP AND ADJUSTING YOUR SUNNI SEAT

7.1 5-POINT HARNESS

The 5-point harness can be easily adjusted and unbuckled to allow the user easy access to the chair whilst also getting a high level of support.

7.1.1 ADJUSTING THE BASE STRAP

- The strap of the 5-point harness (F) is secured to the base with an M6 bolt located at the bottom of the slot in the middle of the base cushion (D).
- Unscrew this bolt using the supplied 4mm hexagon key. This will unsecure the bottom section of the harness.
- This section can be repositioned in this slot and can be secured by securing the bolt into one of the holes in the centre of the base.

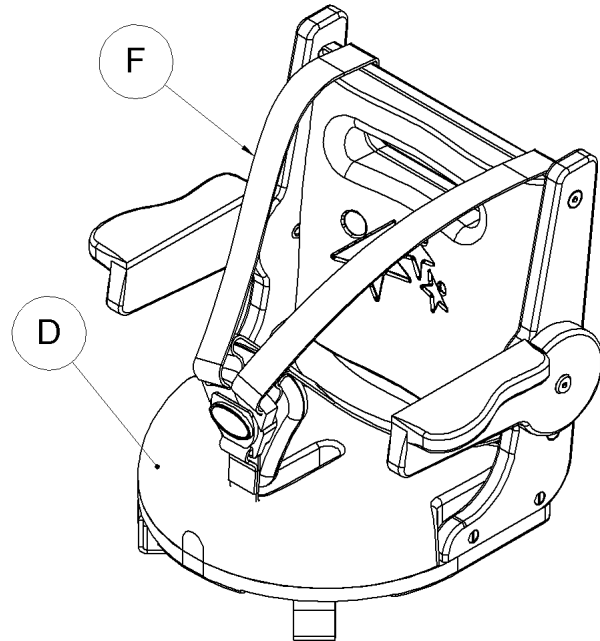

7.1.2 ADJUSTING THE HARNESS

- The harness is secured to the back of the chair in 4 places using Cam locks (G).
- These locks can be released by pulling the tab up.
- Once released, the strap can be moved to tighten or release the harness.
- Push the tab back down to lock the strap in place.

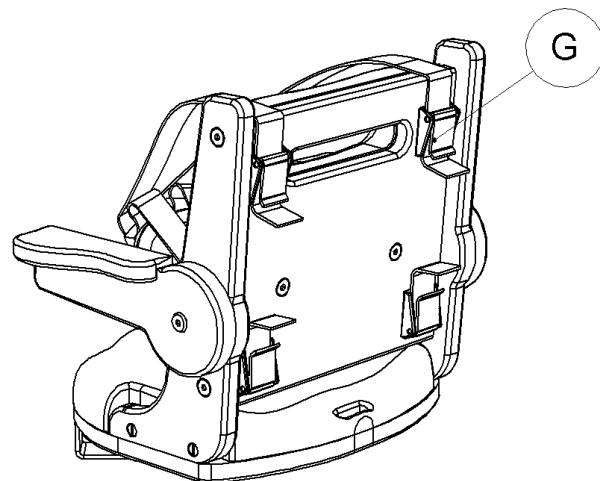

7.1.3 UNBUCKLING/BUCKLING THE HARNESS

- On the front of the harness there is a large red button (H). Press this to release the buckle and the harness will fall away into 3 sections. (I), (J) & (K)
- Once released the user will have more access to get into and get out of the chair.
- To buckle, align the 2 rectangular sections on the buckles on the 2 longer straps (I) & (J) and insert them into the corresponding cavity in the buckle clip (K)

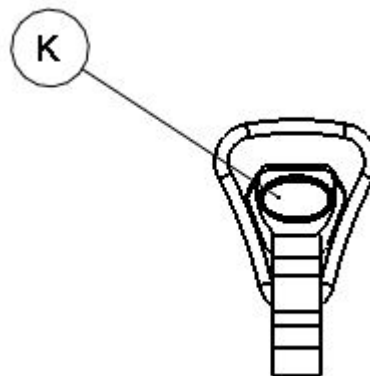
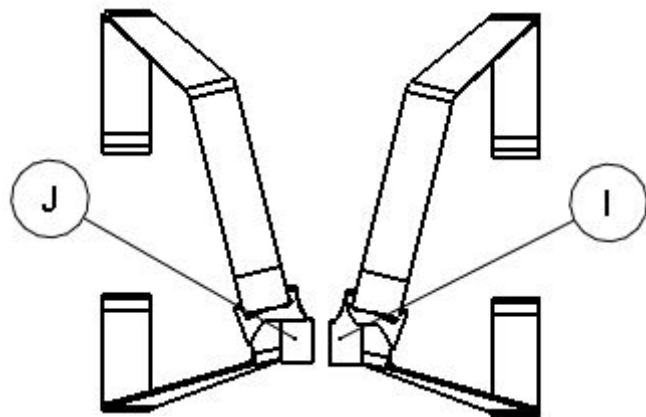
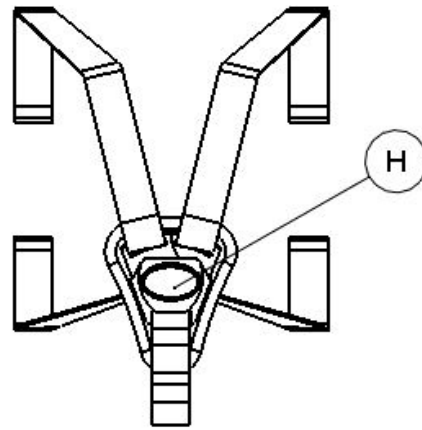

7.2 REMOVING THE CUSHIONS

The cushions can be easily removed from, and attached to the seat by using the supplied M4 hexagon key. Being able to remove the cushions makes it easier to clean or replace them if needed.

7.2.1 REMOVING THE BACK CUSHION

- With one hand, keep a firm grip on the back cushion (C).
- With your other hand undo the two bolts on the back of the chair (L) using the supplied M4 hexagon key.
- When both bolts have been fully undone, the cushion will be able to be removed from the chair

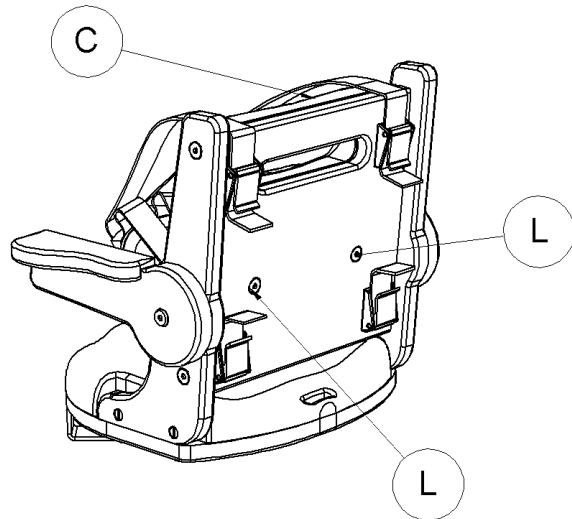

7.2.2 REMOVING THE BASE CUSHION

- Using the supplied M4 hexagon key, undo the 2 bolts on the underside of the chair (M)
- When both bolts have been fully undone, the cushion will be able to be removed from the chair

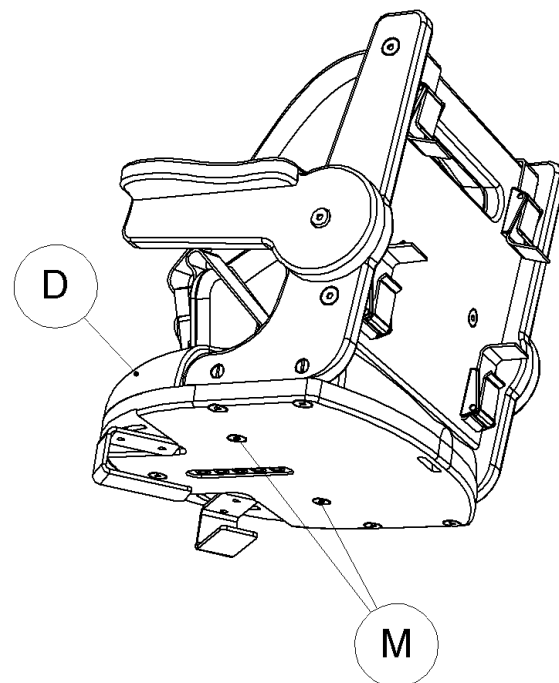

Both cushions can be attached to the chair by aligning the holes in the cushions with the corresponding holes in the frame. Then two bolts per cushion need to be inserted through the frame and threaded into the inserts that are in the cushions.



7.3 ROTATING THE BASE CLIPS

The base clips beneath the chair can be rotated so that the chair can be attached to many different shaped surfaces. To be able to rotate these clips the base cushion must be removed from the chair (see '7.2.2 Removing the Base Cushion').

- With the base cushion removed, the base clips can be rotated by firstly loosening the two bolts in the curved slots towards the front on the chair (N).
- The bolts can be loosened by using the M4 hexagon key. DO NOT completely undo these bolts so that they come away from the chair. Only loosen the bolts in the curved slots.
- Once loosened, the clips will be able to rotate. Once the clips are in the desired position, the bolts can be retightened.

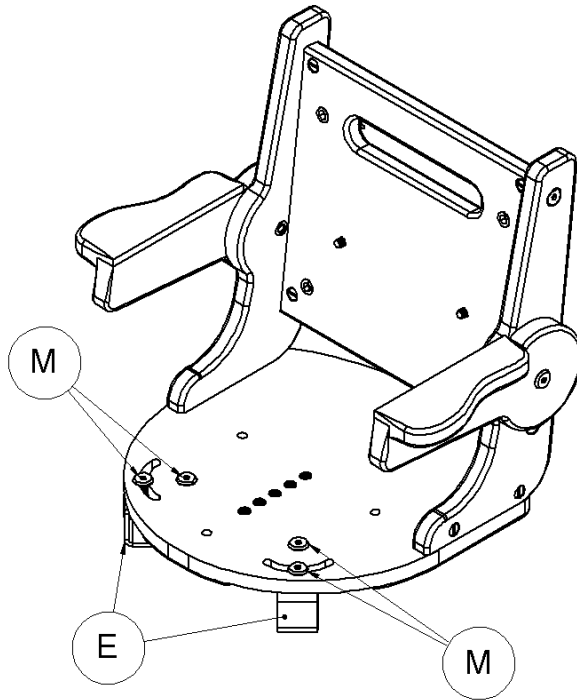

8.0 ACCESSORIES

8.1 SUNNI TRAY

To attach the Sunni Tray;

- Place tray onto arm tops (ensuring tab (O) is in the open location).
- Twist tab (O) into the closed location to keep tray in place.

Open

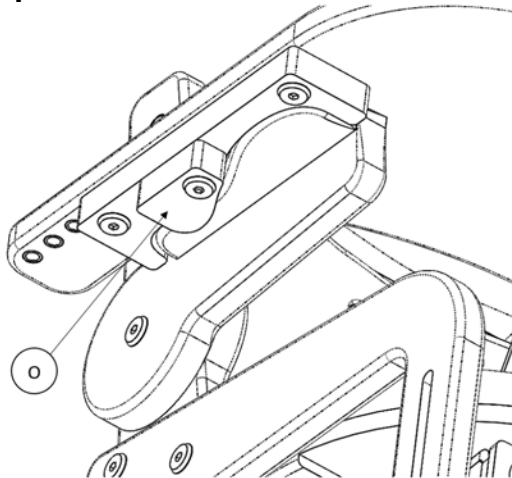

Closed

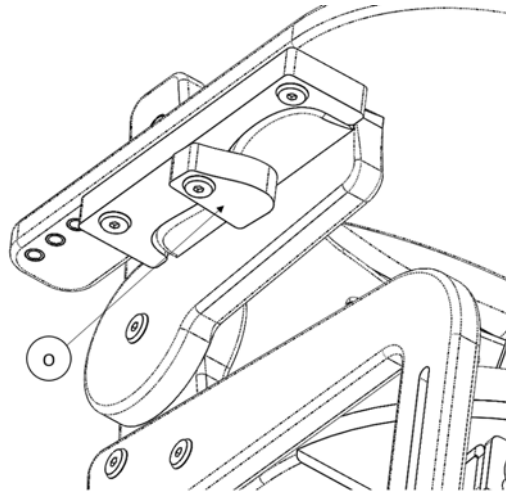

To adjust the tray depth;

- Remove bolts (N) (Two per side).
- Locate into desired position, using the holes on the bottom of the tray.
- Retighten the bolts (N) in desired location.

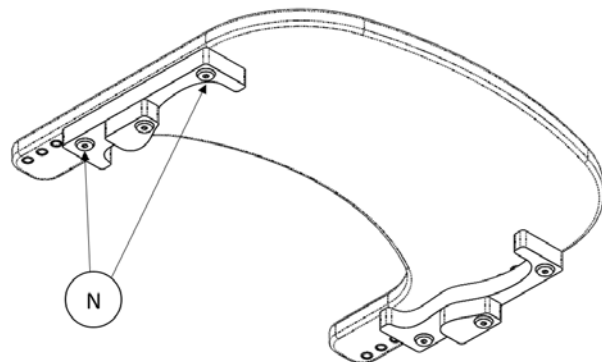

8.2 FOOTREST

To Attach the footrest;

- Align the holes on the side of the chair with the corresponding holes (P) in the footrest sides.
- Insert and tighten all four bolts (Q) (two per side)

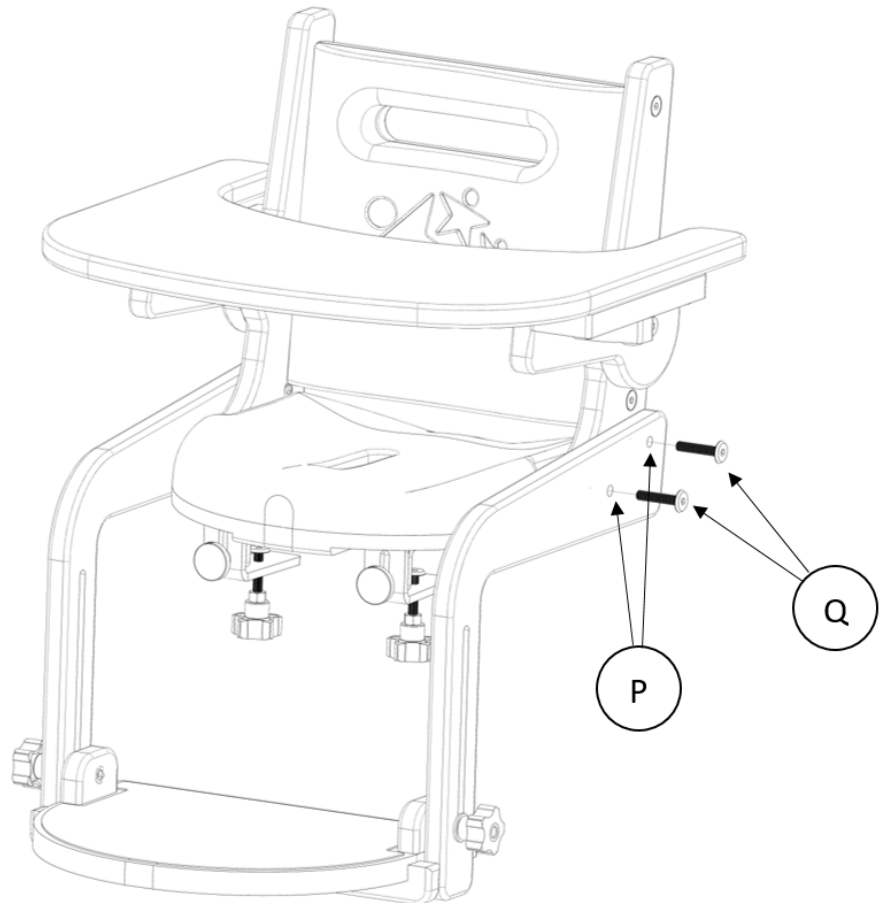

To adjust the height of the footrest;

- Loosen handwheels (R).
- Lift footplate to desired height.
- Retighten handwheels (R).

To Flip up the footplate;

- Loosen handwheels (R).
- Flip Footplate up 90 degrees
- Retighten handwheels (R).

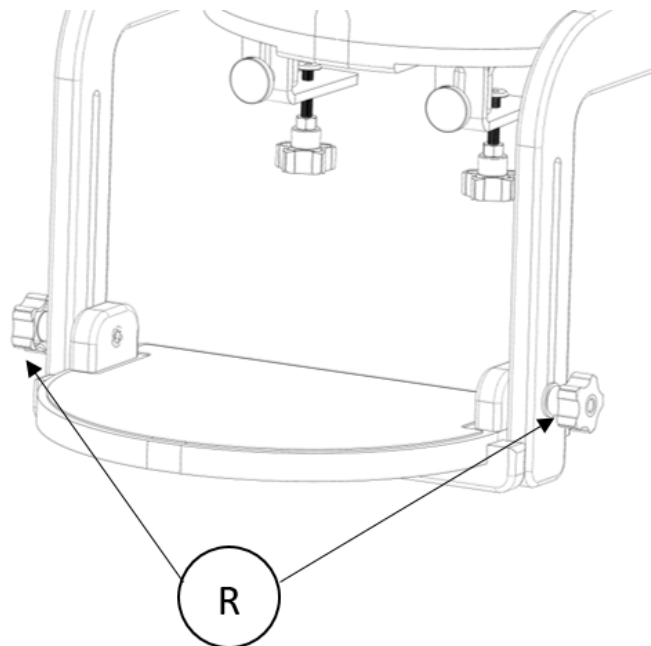

9.0 SAFETY STRAP

To Attach the safety strap;

- Loop strap (W) through slot (S) in the back of the seat.
- Thread the loose end of the strap (W) back through the buckle (T), pulling until tightly secured.
- Loop the other end of the strap (V) around the secure point.
- Thread the loose end of the strap (V) back through the buckle (T), pulling until tightly secured.
- Clip the buckle (U) together securing the Sunni to the secure point.
- Retighten both loose ends, ensuring the Sunni is completely secure.

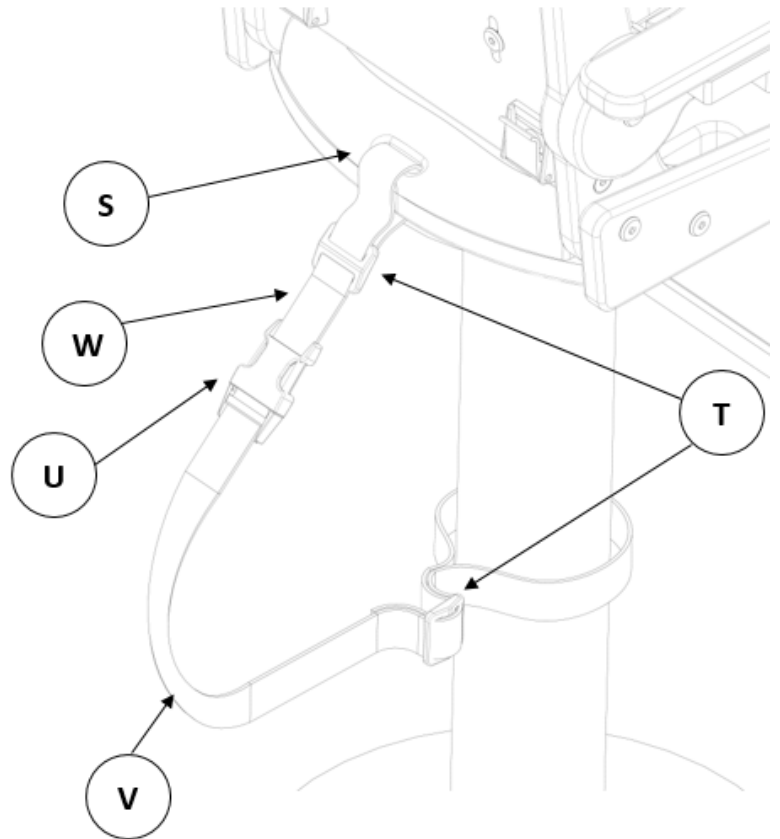

9.1 SAFETY STRAP BUCKLE

To operate the buckle;

- To fasten, simply connect the two parts, the buckle will 'click' and lock in place.
- To unfasten, press areas (X) to unlock the buckle and pull the two buckles apart.

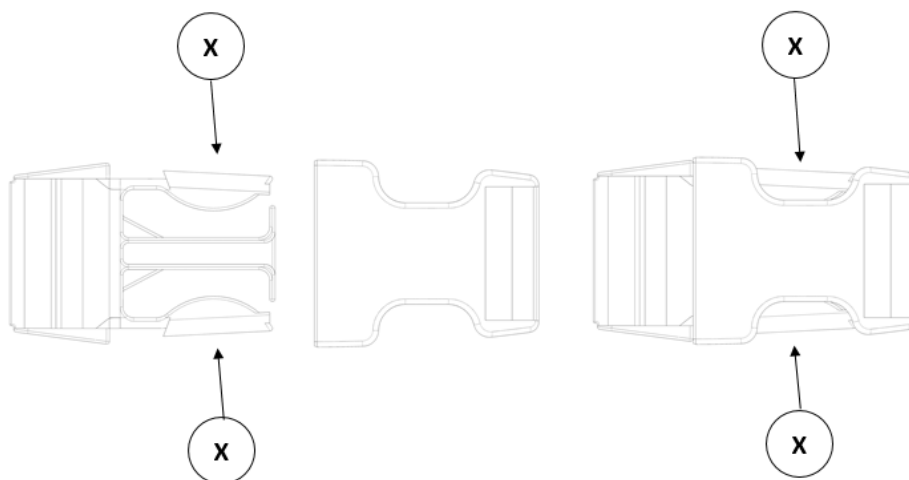

9.2 SAFETY STRAP TOGGLE

To operate the safety strap toggle;

- Thread the end of the strap into the toggle (Y) in the direction of the grey arrows, looping out, around and down through the toggle (Y).
- Loop the free end of the strap around the desired object.
- Bring the loose end back through the toggle (Y) following the black arrows, looping out, around and down through the toggle (Y).
- To tighten, pull on the loose end of the strap.

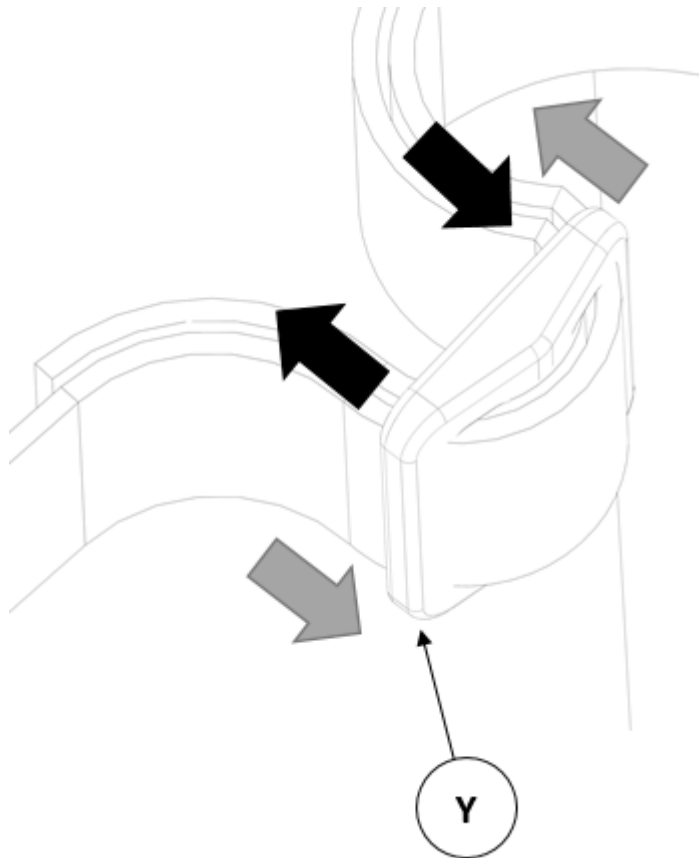

10.0 CARE AND MAINTENANCE



IMPORTANT!

CLEANING IS RECOMMENDED ON A REGULAR BASIS

- Clean upholstery and wooden parts with a damp cloth and mild detergent.
- Stubborn marks on the woodwork should be cleaned by using a soft brush.
- Do not soak or immerse the chair in water.
- Store the chair in a cool dry place out of direct sunlight.
- DO NOT use bleach, solvents, abrasives, synthetic detergents, wax polishes, antibacterial sprays or wipes.
- For further information, please refer to MHRA or your NHS cleaning guidelines.



10.1 DAILY CHECKS

- Check the upholstery for signs of wear and tears.
- Check that all bolts are tightened correctly and are not cross-threaded or damaged.
- Ensure the base clips are secure and are not free to rotate.
- Check that the arms rests are free to rotate.



STOP!

The user should not be seated while the checks are carried out.

10.2 SERVICE INTERVAL

The Sunni Seat should be serviced every 3 years. Servicing must only be undertaken by a Smirthwaite service engineer, or by a Smirthwaite trained representative.

10.3 NOMINAL SERVICE LIFE

Your product has a nominal service life of 12 years, during which full post-sales support will be available with regard to spares and servicing.

Product service life has been determined based upon the design complexity of product, and the anticipated exposure to normal use.

Good practice dictates all Smirthwaite products have been designed and manufactured to high levels of safety and quality, and will meet requirements of normal use when maintained in line with our servicing recommendations.



STOP!

If the product has been out of use for an extended period of time (6 months or more) it should always be serviced prior to being reissued.

If the product has been subjected to 'heavy' or 'constant' use, the service should be reduced to half the recommended period. Constant and/or heavy use is considered to be:

- Daily use above 7 hours duration
- Weekly use above 5 days duration
- Monthly use above 10 months per year
- Use by a client who is at 90% to 100% of the maximum weight limit of the product. The maximum weight limit must **NEVER** be exceeded
- Use by a client who is extremely active, either voluntarily or involuntarily



10.4 EXTENDING NOMINAL SERVICE LIFE

At Smirthwaite we are proud to produce products that have a reputation for quality and durability.

We believe our products have the potential to provide benefits to our clients beyond the nominal service life documented above.

We will continue to provide full support beyond the nominal service life provided the following conditions are met:

1. A full service schedule has been maintained.
2. A full service and inspection is undertaken at the end of the nominal service life period.
3. The product is subsequently serviced annually (or biannually if under 'heavy/constant' use conditions).
4. Smirthwaite reserve the right to limit support where parts/components are no longer available.

8.5 DOCUMENTATION/RECORDS

- It is the responsibility of the current equipment owner to ensure the 'Instructions for Use' manual and any further manuals for accessories fitted to the equipment are handed over to the new owner at the time of exchange/sale.
- It is the responsibility of the current equipment owner to ensure the service and inspection record form is kept up to date.

8.6 PRODUCT CONFIGURATION

- Smirthwaite will document and maintain a record of the original product configuration at the time of first sale.
- Smirthwaite will not be held responsible for any subsequent changes to this configuration unless authorized to do so in writing by Smirthwaite Ltd.
- It is the equipment owner's responsibility to maintain their own records of changes to the equipment configuration and to be able to provide such records to subsequent owners to maintain traceability.
- We recommend an inspection/service by a Smirthwaite Service Engineer (or Smirthwaite trained engineer) whenever a significant change is made to product configuration to ensure the product is safe to use. **If in any doubt, ALWAYS seek ADVICE**





IMPORTANT!

DO NOT fit parts or accessories of other manufacturers to this product unless authorized to do so in writing by Smirthwaite Ltd.

Any servicing or repairs required must be carried out by Smirthwaite Ltd (or a Smirthwaite trained engineer).

If you believe this product to be faulty – DO NOT USE – Contact Smirthwaite Ltd

If in any doubt, ALWAYS seek ADVICE.

9.0 WARRANTY & SERVICE

Smirthwaite Ltd warrants the products detailed on your order to be free from defects in materials and workmanship for a period of 2 years from date of delivery. If a fault develops during the period, please call Customer Services by email or telephone who will advise you on the best course of action. Possible action may be for us to arrange to send out one of our Service Engineers, or have the goods returned to us. Should a repair not be possible within the guarantee period we will replace the product for new or nearest equivalent product. In the unlikely event that we cannot repair or exchange we will refund in full.

This warranty is for the UK only. The warranty excludes faults due to accident, neglect, misuse, not following the Instructions and normal wear and tear. This warranty is in addition to your legal rights. Goods will only be collected from the original delivery address.

A charge may be made where the goods cannot be repaired under the terms of the warranty. You will be advised before this is made.

10.0 CONTINUOUS IMPROVEMENT

Smirthwaite Ltd are committed to continuous improvement to their product range. Should you have any suggestions or comments please send them to our product design department

Smirthwaite Ltd reserve the right to change the specification or material without prior notice.

For catalogues, help and further information on our products please contact us at:
Smirthwaite Ltd 16 Wentworth Road Heathfield, Devon.TQ12 6TL



11.0 SERVICE INSPECTION

11.1 PRODUCT INFORMATION

Model:	
Size:	
Date of Manufacture:	
Serial Number:	
Final Inspection:	

11.2 SERVICE & INSPECTION RECORD FORM

Date	Procedure	Service Personnel

